

NEMA 182/4TC FLANGE
Ø8.500 PILOT
Ø7.25 BOLT CIRCLE

NEMA 182/4TC
Ø1.125
0.250 SQUARE KEY

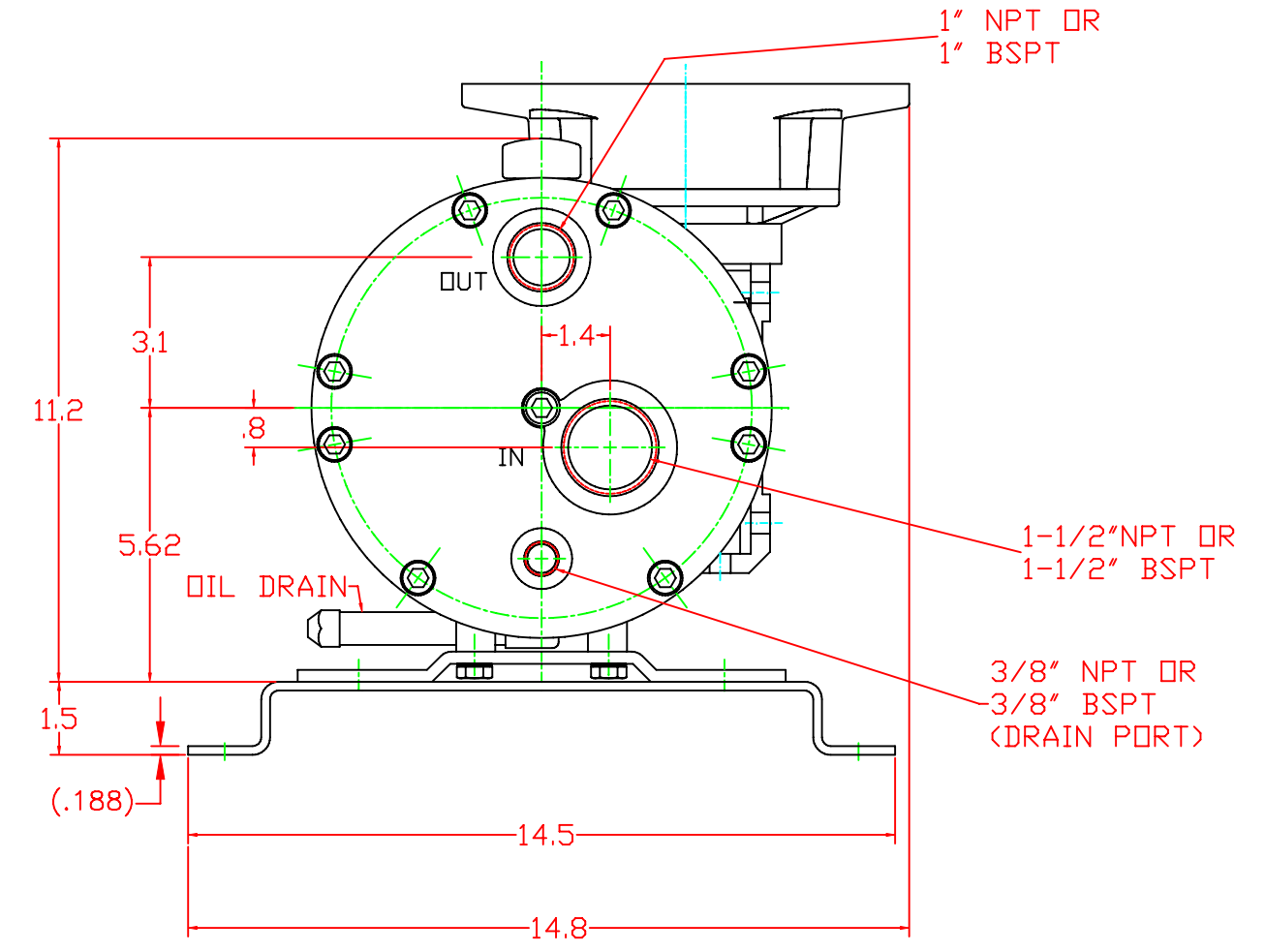
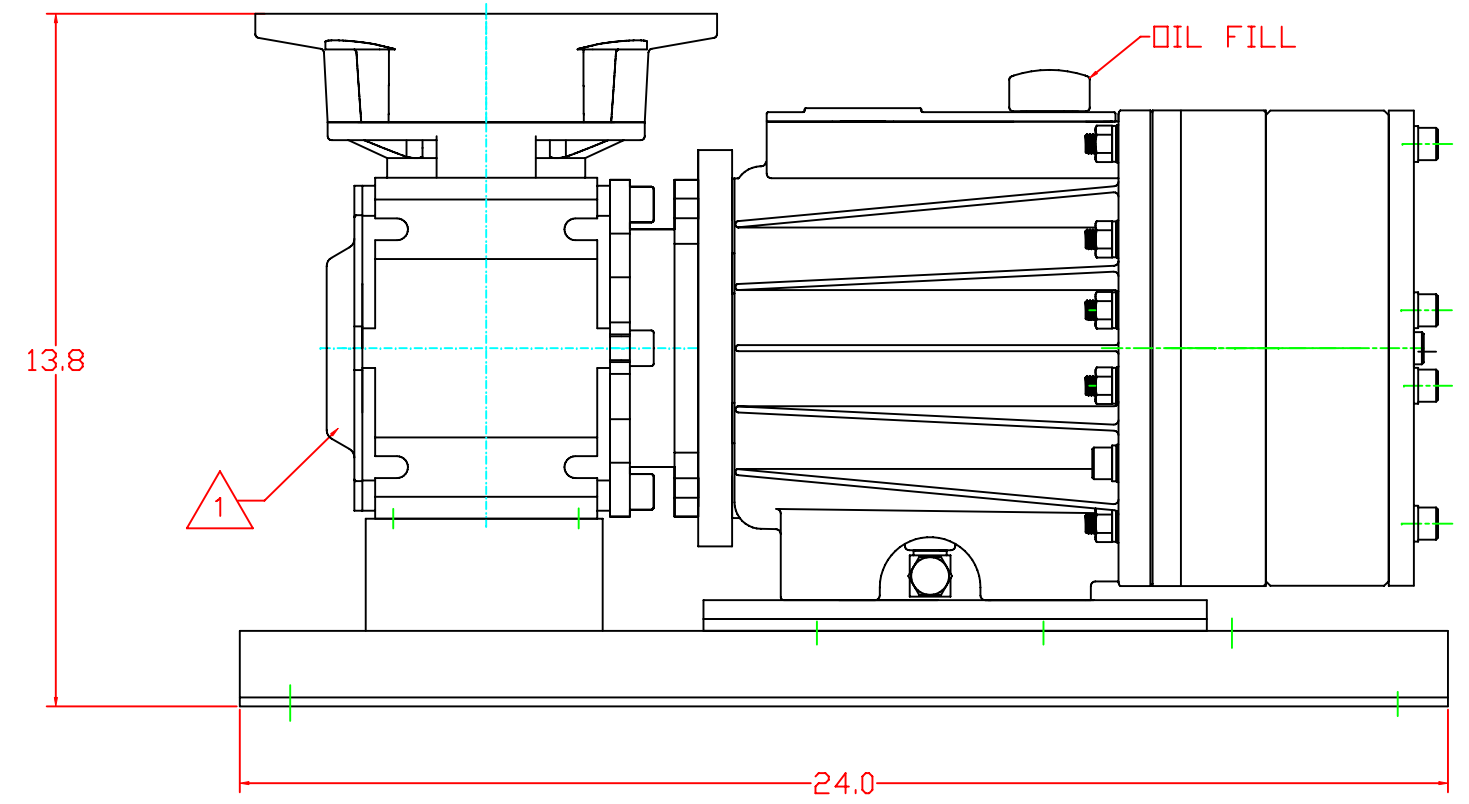
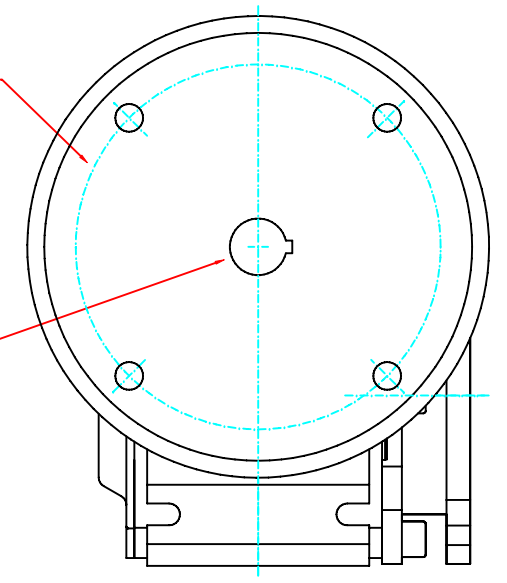

NOTES:

1. WORM GEAR REDUCER AVAILABLE IN THE FOLLOWING RATIO'S:
- 5:1, 7.5:1, 10:1

2. WEIGHT = 146 LBS (66 KG) - DOES NOT INCLUDE MOTOR.

UNLESS OTHERWISE SPECIFIED		MAT'L PUMPING HEAD AVAILABLE IN POLYPROPYLENE OR KYNAR	
- ALL DIMENSIONS ARE IN INCHES.	TOL UNLESS NOTED	DWN 05-30-06 JJH	WANNER ENGINEERING INC
- DRAWING MAY NOT BE TO SCALE	.X = ± .020	CHK'D	1204 CHESTNUT AVE. MPLS, MN 55403
- ALL DIMENSIONS APPLY AFTER PLATING, COATING AND HEAT TREATING, BUT BEFORE PAINTING.	.XX = ± .010	APP'D	TITLE
- REMOVE ALL BURRS, BREAK ALL SHARP EDGES AND CORNERS	.XXX = ± .005	USED ON:	DIM DWG, P600, FB75, 180TC
PROPRIETARY STATEMENT	ANGLES = ± .50°	SHEET 1 OF 1	DWG NO
This document contains confidential and proprietary information and is not to be reproduced or the information contained therein disclosed to others without consent, in writing, from WANNER ENGINEERING INC.	FINISH: 125 RMS	SCALE 1:2	P600-DIM-PLASTIC-FB75-180TC-BASE
		FORM DBLK	REV.
			A