

Frame Mounted End Suction, Flanged Connection

PUMP NO.	PUMP:	MOTOR:	VOLTS:
FOR:	TDH:	HP:	HZ:
CERT. BY:	GPM:	RPM:	FRAME:
DATE:	FIGURE NO:	PHASE:	ENCLOSURE:

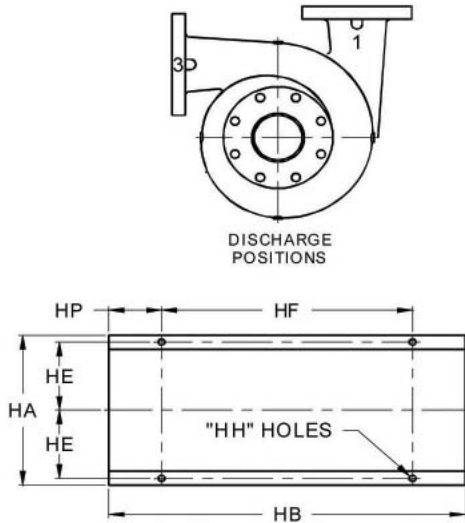

CONNECTIONS FOR 125# STANDARD FLANGES								
PUMP	DISCH. (INCH)	INLET (INCH)	HL	X	Y	Z	CP	DD
1G-2A	1	1.25	10.44	5.00	4.33	4.10	19.94	5.00
1.5G-2A	1.5	2	9.63	5.70	3.58	4.30	19.13	5.63
1.5G1-2A	1.5	2	9.63	5.70	3.58	4.30	19.13	5.63
1.5GT-2A	1.5	3	11.38	5.70	5.33	4.30	20.88	5.63
1.5K-2A	1.5	2	10.00	6.50	3.65	6.70	19.56	7.25
1.5K1-2A	1.5	2	10.00	6.50	3.65	6.70	19.50	7.25
1.5KH-2A	1.5	2	10.38	7.50	4.87	6.70	20.00	8.00
2G-2A	2	3	10.13	5.50	4.13	4.50	19.63	5.81
2K-2A	2	3	10.00	6.70	3.83	6.00	19.56	7.50
2.5G-2A	2.5	3	10.19	6.25	4.03	4.50	19.69	6.06
2.5K-2A	2.5	3	10.44	7.00	4.06	6.25	19.88	7.69
3G-2A	3	4	11.00	6.00	4.63	4.80	20.50	6.63
3K-2A	3	4	10.88	7.50	4.48	6.50	20.38	8.13
3K1-2A	3	4	10.88	7.50	4.48	6.50	20.38	8.13
4G-2A	4	5	11.25	6.75	4.77	5.50	20.75	7.38
4G1-2A	4	5	11.25	6.75	4.77	5.50	20.75	7.38
4GL-2A	4	5	11.25	6.75	4.77	5.50	20.75	7.38

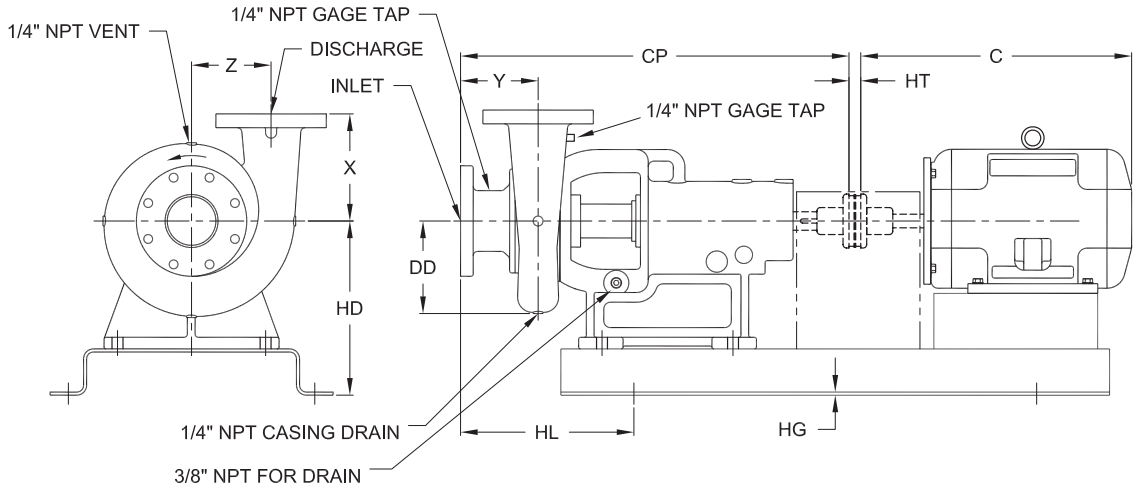

NOTES: 1) All dimensions $\pm .13$ 2) Dimension C will vary based on motor brand

DIMENSIONS IN INCHES

MOTOR FRAME	BASE NO.	C		HA	HB	HD	HE	HF	HG	HH	HP	HT
		ODP	TEFC									
48	010031	9.63	10.75	15.50	30.00	10.50	6.75	22.00	.25	.75	4.00	.63
56	010029	11.25	13.38	15.50	30.00	10.50	6.75	22.00	.25	.75	4.00	.38
143T	010030	12.81	11.50	15.50	30.00	10.50	6.75	22.00	.25	.75	4.00	.56
145T	010030	12.81	11.50	15.50	30.00	10.50	6.75	22.00	.25	.75	4.00	.56
182T	010032	13.63	16.13	15.50	30.00	10.50	6.75	22.00	.25	.75	4.00	.63
184T	010032	13.63	16.13	15.50	30.00	10.50	6.75	22.00	.25	.75	4.00	.63
213T	010033	15.50	18.63	15.50	30.00	10.50	6.75	22.00	.25	.75	4.00	.88
215T	010033	17.00	20.13	15.50	30.00	10.50	6.75	22.00	.25	.75	4.00	.88
254T	010034	20.31	23.75	19.00	36.00	10.50	8.50	28.00	.31	.75	4.00	1.00
256T	010034	22.06	25.50	19.00	36.00	10.50	8.50	28.00	.31	.75	4.00	1.00
284TS	010035	22.00	24.75	19.00	36.00	10.50	8.50	28.00	.31	.75	4.00	1.00
286TS	010035	23.50	26.25	19.00	36.00	10.50	8.50	28.00	.31	.75	4.00	1.00

Types "G, GL, GT, K & KH"
 End Suction Frame Pumps No. 2A Bearing Frame
 Metric (Millimeters)



www.cranepumps.com

Frame Mounted End Suction, Flanged Connection

PUMP NO.	PUMP: TDH: GPM:	MOTOR: HP: RPM: PHASE: ENCLOSURE:	VOLTS: HZ: FRAME:
FOR:	FIGURE NO:		
CERT. BY:	DATE:		

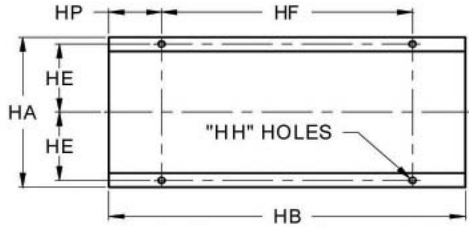
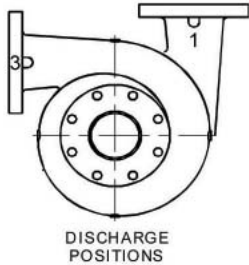

CONNECTIONS FOR 125# STANDARD FLANGES								
PUMP	DISCH. (INCH)	INLET (INCH)	HL	X	Y	Z	CP	DD
1G-2A	1	1.25	265	127	110	104	506	127
1.5G-2A	1.5	2	244	144	91	109	486	143
1.5G1-2A	1.5	2	244	144	91	109	486	143
1.5GT-2A	1.5	3	289	144	135	109	530	143
1.5K-2A	1.5	2	254	165	92	170	497	184
1.5K1-2A	1.5	2	254	165	92	170	497	184
1.5KH-2A	1.5	2	263	190	123	170	508	203
2G-2A	2	3	257	139	105	114	499	148
2K-2A	2	3	254	170	97	152	497	191
2.5G-2A	2.5	3	258	158	102	114	500	154
2.5K-2A	2.5	3	265	177	103	158	505	195
3G-2A	3	4	279	152	117	122	521	168
3K-2A	3	4	276	190	113	165	518	206
3K1-2A	3	4	276	190	113	165	518	206
4G-2A	4	5	285	171	121	139	527	187
4G1-2A	4	5	285	171	121	139	527	187
4GL-2A	4	5	285	171	121	139	527	187

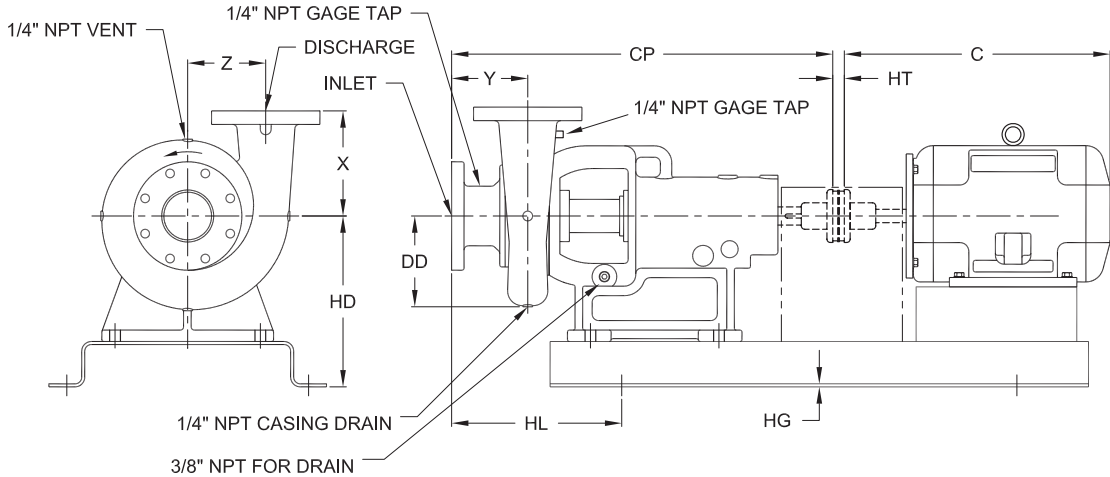

NOTES: 1) All dimensions $\pm .13$ 2) Dimension C will vary based on motor brand

DIMENSIONS IN MILLIMETERS

MOTOR FRAME	BASE NO.	C		HA	HB	HD	HE	HF	HG	HH	HP	HT
		ODP	TEFC									
48	010031	245	273	394	762	267	171	559	6	19	102	16
56	010029	286	340	394	762	267	171	559	6	19	102	10
143T	010030	325	292	394	762	267	171	559	6	19	102	14
145T	010030	325	292	394	762	267	171	559	6	19	102	14
182T	010032	346	410	394	762	267	171	559	6	19	102	16
184T	010032	346	410	394	762	267	171	559	6	19	102	16
213T	010033	394	473	394	762	267	171	559	6	19	102	22
215T	010033	432	511	394	762	267	171	559	6	19	102	22
254T	010034	516	603	483	914	267	216	711	8	19	102	25
256T	010034	560	648	483	914	267	216	711	8	19	102	25
284TS	010035	559	629	483	914	267	216	711	8	19	102	25
286TS	010035	597	667	483	914	267	216	711	8	19	102	25

SECTION 500
 PAGE 14
 DATE 12/10



PUMPS & SYSTEMS

A Crane Co. Company

USA: (937) 778-8947 • Canada: (905) 457-6223 • International: (937) 615-3598