

# TANK ASSEMBLY INSTRUCTION

## Classic, BDF & SVP Pump Series

**NOTICE:** Before installing or servicing the pump, read the pump manual for all safety information and complete instructions. The pump is designed for installation and service by properly trained personnel.

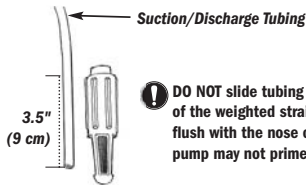
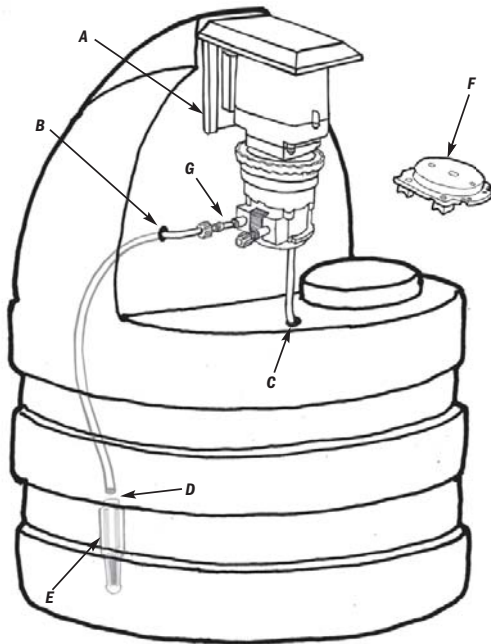

**DO NOT** slide tubing all the way to the bottom of the weighted strainer. Tubing could become flush with the nose of the strainer and the pump may not prime due to blockage.

### TANK ACCESSORIES

- 2 Mounting bracket screws
- 2 Grommets 1/4"
- 1 Grommet 3/8"

NOTE: Tanks for BDF or SVP pump also includes  
 1 Motor base  
 1 Motor base screw (self-tapping)

### MOUNTING BRACKET

- 1 Attach mounting bracket screw to the lowest hole in the tank and leave it loose enough to slide the mounting bracket under the screw head. Then slide bracket **A** under the screw head.
- 2 Attach the 2nd mounting bracket screw to secure the top of the mounting bracket and tighten both screws. **DO NOT** slide pump into bracket at this time.  
 NOTE: Motor base stops are located in the mounting bracket. Mount with directional arrow facing downward.

### GROMMETS

- 1 Measure and mark the two locations **B** & **C** to drill the holes. Location **C** is for 1/4" grommets only.
- 2 Drill proper hole sizes.  
 1/4" grommet: 3/8" drill bit  
 3/8" grommet: 1/2" drill bit
- 3 Install applicable grommets into holes. **B** & **C** show the recommended hole locations which may vary based on the application or user's requirements

**IMPORTANT!** Failure to clean all debris inside the tank prior to use may lead to pump tube rupture or malfunction.

### SUCTION LINE

- 1 You'll need the following accessories that were shipped with the Stenner pump:  
 20' suction/discharge tubing  
 1 of 3 connecting nuts  
 1 of 3 ferrules  
 1 weighted strainer
  - 2 Insert suction tubing through the grommet location **B** until it is 2"-3" from the bottom of the tank.
  - 3 Remove fill cap.
  - 4 Reach inside tank and insert 4" of tubing into the collet **D** and twist to lock the tubing and collet **E** onto the strainer.
  - 5 Adjust tubing to maintain weight 2"-3" from the tank bottom.
- IMPORTANT!** **DO NOT** allow the weight to rest on the bottom of the tank.
- 6 Cut the tubing to leave approximately 9" from location **B**. The tubing will be connected to the suction side of the pump head later in the installation.

### PUMP HEAD COVER PREPARATION FOR SPILL RECOVERY

NOTE: The spill recovery option can only be used with 1/4" tubing.

- 1 Cut a 6" section of 1/4" tubing and insert through the spill recovery grommet **C**.
- 2 Unlatch and remove pump head cover.
- 3 Punch out one of two hole plugs using a 7/32" punch **F**.
- 4 Reinstall pump head cover, secure latches.

### FEED PUMP ATTACHMENT AND CONNECTIONS

- 1 Slide pump into mounting bracket **A**.
- 2 Insert the end of the tubing extending out from the spill recovery grommet into the pump head cover but not inside the pump head.
- 3 Connect suction tubing to suction side of the pump **G** with connecting nut and ferrule. Connection should be "finger tight" only. **DO NOT** use pliers, thread tape or pipe dope.
- 4 Complete the installation with the instructions found in the pump manual.

## Pump Motor Base Attachments For BDF & SVP Pump Series

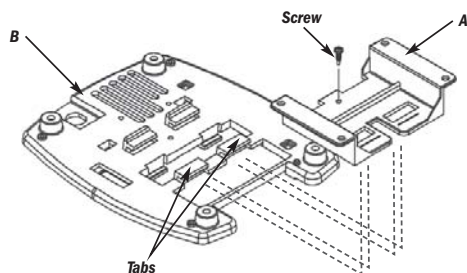

- 1 Align motor base **A** as indicated to (SVP/BDF) motor base **B**. Motor base **A** slides and locks into the two tabs.
- 2 Secure the motor base **A** to motor base **B** with the screw provided.

