

# ECON SERIES T SPECIFICATIONS

# STENNER PUMPS

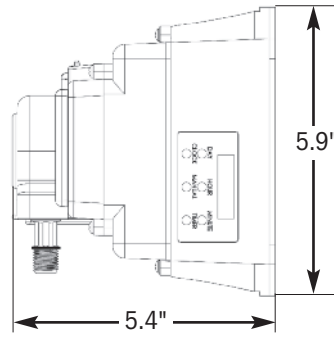

**SHIPPING WEIGHT** 4 lbs (1.8 kg)

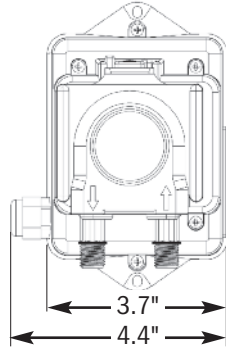

  
**USA**  
 THIS PUMP IS TESTED AND CERTIFIED BY WQA ACCORDING TO NSF/ANSI 61 FOR CONTACT WITH SODIUM HYPOCHLORITE AND WATER ONLY AND NSF/ANSI 372.

  
**LISTED**  
 METERING PUMP  
 4TF1

## FEATURES

- 3-point roller design assists in anti-siphon protection
- Pump head requires no valves, allows for easy maintenance
- Self-priming against maximum working pressure, foot valve not required
- Pump does not lose prime or vapor lock
- Pumps off-gassing solutions and can run dry
- Output volume is not affected by back pressure
- Easy to change pump tube; lubrication is not required
- All pump accessories included allow a fast and easy installation

## OUTPUT

Item Number Prefix	Pump Tube	Roller Assembly	Gallons per Day	Gallons per Hour	Ounces per Minute	Pressure psi	Liters per Day	Liters per Hour	Milliliters per Minute	Pressure bar
E10T1F*	F	White	0.6	0.02	0.05	80	2.2	0.09	1.5	5.5
E10T2F*	F	White	1.3	0.05	0.11	80	4.8	0.20	3.3	5.5
E10T1A	A	White	2.5	0.10	0.22	25	9.5	0.39	6.6	1.7
E10T2A	A	White	5.0	0.21	0.44	25	18.9	0.79	13.1	1.7
E10T2B	B	White	8.5	0.35	0.76	25	32.2	1.34	22.3	1.7
E10T2C	C	White	15.0	0.63	1.33	25	56.8	2.37	39.4	1.7

Approximate Maximum Outputs @ 50/60Hz

\* Injection check valve included with pumps rated 80 psi (5.5 bar)



**NOTICE:** The information within this chart is solely intended for use as a guide. The output data is an approximation based on pumping water under a controlled testing environment. Many variables can affect the output of the pump. Stenner Pump Company recommends that all metering pumps undergo field calibration by means of analytical testing to confirm their outputs.

## OUTPUT CONTROL

24-hr programmable clock; 7 day, 24 event timer

### MAXIMUM WORKING PRESSURE

**80 psi (5.5 bar)** E10T1F, E10T2F

**25 psi (1.7 bar)** E10T1A, E10T2A, E10T2B, E10T2C

### MAXIMUM OPERATING TEMPERATURE

104° F (40° C)

### MAXIMUM SUCTION LIFT

25 ft (7.6 m) vertical lift, based on water

**MOTOR TYPE** 24 VDC, brushed

**APPROXIMATE SHAFT RPM** 9 or 18

**DUTY CYCLE** Continuous

**MOTOR VOLTAGE (AMP DRAW)** 120V 60Hz (1.7)

**POWER CORD TYPE** STP-2W

### POWER CORD PLUG END

Wall adapter power supply 100-120V, 60Hz

0.25 input, two prong polarized 24VDC, 1.25A, class II output

## MATERIALS OF CONSTRUCTION

**All Housings** Polycarbonate

**Pump Tube & Check Valve Duckbill**

Santoprene™, FDA approved

**Pump Head Rollers** Polyethylene

**Suction/Discharge Tubing, Ferrules**

Polyethylene, FDA approved

**Tube Fittings** Polypropylene, NSF listed

**Check Valve Fittings**

Type 1 Rigid PVC, NSF listed

**Connecting Nuts** PP or Type 1 Rigid PVC

**Suction Line Strainer** PP or Type 1 Rigid PVC

body with Type 1 Rigid PVC cap, NSF listed; ceramic weight

**All Fasteners** Stainless steel

\* Santoprene™ is a registered trademark of Exxon Mobil Corporation.

## ACCESSORY KIT SHIPPED WITH EACH PUMP

**3** connecting nuts 1/4"

**3** ferrules 1/4" or 6 mm *Europe*

**1** injection check valve 80 psi (5.5 bar)  
OR 1 injection fitting 25 psi (1.7 bar)

**1** weighted suction line strainer 1/4"

**1** 20' roll suction/discharge tubing

1/4" white or UV black

OR 6 mm white *Europe*

**1** additional pump tube

**1** manual

This information is not intended for specific application purposes. Stenner Pump Company reserves the right to make changes to prices, products, and specifications at any time without prior notice.

FETSPEC 0912



**STENNER PUMP COMPANY**

Jacksonville, Florida USA

www.stenner.com

© Stenner Pump Company All Rights Reserved