

STAN-COR

*ANSI, solid Kynar or Teflon
non-metallic centrifugal pumps*



***Designed specifically for dirty,
abrasive, corrosive process fluids***

 **WANNER ENGINEERING INC**

STAN-COR

The ANSI pump that sets the industry standard for difficult process fluid applications



- *Designed by the process industry for the process industry*
- *Cost-effective, rugged and durable design*
- *Smooth, full-curve performance*

Stan-Cor Series pumps provide exclusive design advantages over all other centrifugal pumps. For applications requiring durability and performance on dirty, difficult fluids, Stan-Cor pumps are by far the most cost-effective solution.

Applications

Stan-Cor Series pumps are specifically designed to handle abrasive, corrosive, dirty and reclaim process fluids like no other pump can:

- Hydrochloric acid
- Hydrofluoric w/lime
- Sodium hydroxide
- Sulfuric acid
- Plating solutions
- Semi-conductor waste water
- Pickling solutions
- Chlorinated hydrocarbon
- Acid recovery
- Lime slurries
- Bleaching
- Spent caustics
- Grit removal
- Paints

1 Heavy-duty Bearings

Stan-Cor's duplex angular contact thrust bearings in the rear withstand far greater radial and axial thrust than conventional bearings.

2 Bearing Housing

External adjustment of rear bearing housing is used to set impeller clearance ensuring zero end play for maximum mechanical seal life.

3 Optimized Shaft Design

Optimized shaft design features maximum diameter-to-length ratio, minimal overhang, and extra heavy-duty support to minimize shaft deflection and associated seal wear.

4 Oil Bath Reservoir

Oil bath reservoir with overflow sight glass keeps bearings fully lubricated.

5 Seal Options

Variety of seal options available.

6 Materials of Construction

Kynar 370, a 20% graphite-filled PVDF material is thermally stable to maintain tight dimensions. For severe corrosives or high temperatures, solid glass filled TFE Teflon is also available.

7 Impeller

Molded from solid Kynar 370¹ or TFE Teflon², Stan-Cor semi-open tapered impellers are machined to the exact diameter required to control performance. Additional back pump out vanes produce low stuffing box pressures and keep seal area clear of debris.

8 Casing

Stan-Cor pumps have a concentric casing (see illustration at right), which greatly reduces turbulence and vibration, extends seal and bearing life, eliminates excessive hydraulic imbalances and allows the pump to run anywhere between a few GPM to maximum flow without undue shaft deflection. The design allows the Stan-Cor pump to handle abrasives much better than standard open impeller centrifugal pumps.

- *Solid Kynar or Teflon pump head for chemical compatibility and excellent abrasion resistance*
- *Concentric casing design for better flow patterns than other centrifugal pumps— less turbulence, longer seal life, reduced shaft deflection*
- *Handles high temperatures*
- *Compact design features including heavy-duty drive shaft, adjustable bearing supports, and large capacity oil bath ensure low maintenance, durable performance for the toughest fluid applications*
- *Back pull-out design for easy servicing*

Typical Volute-Type Centrifugal Pump
showing excessive turbulence and eddies



STAN-COR Concentric Casing Pump
showing smooth flow pattern



• Total Dynamic Head to 350 Feet • Flow Rates to 700 GPM

Stan-Cor ANSI Centrifugal Pumps are *the standard* for corrosion resistance and abrasive fluids. They offer *solid* fluid ends (casing, suction cover and impeller) in two different materials for chemical resistance and temperature limits. Because these sections are solid in Stan-Cor pumps, there is no loss of corrosion resistance from abrasion, dents, gouges, cavitation, vacuum, turbulence and permeability. Corrosive materials do not come in contact with any metal parts of the pump.



Selection

Use the selection chart below to determine the appropriate Stan-Cor pump model and size for your application. Please contact Wanner Engineering or your local Stan-Cor distributor for exact sizing of a Stan-Cor pump to your specific application requirements.

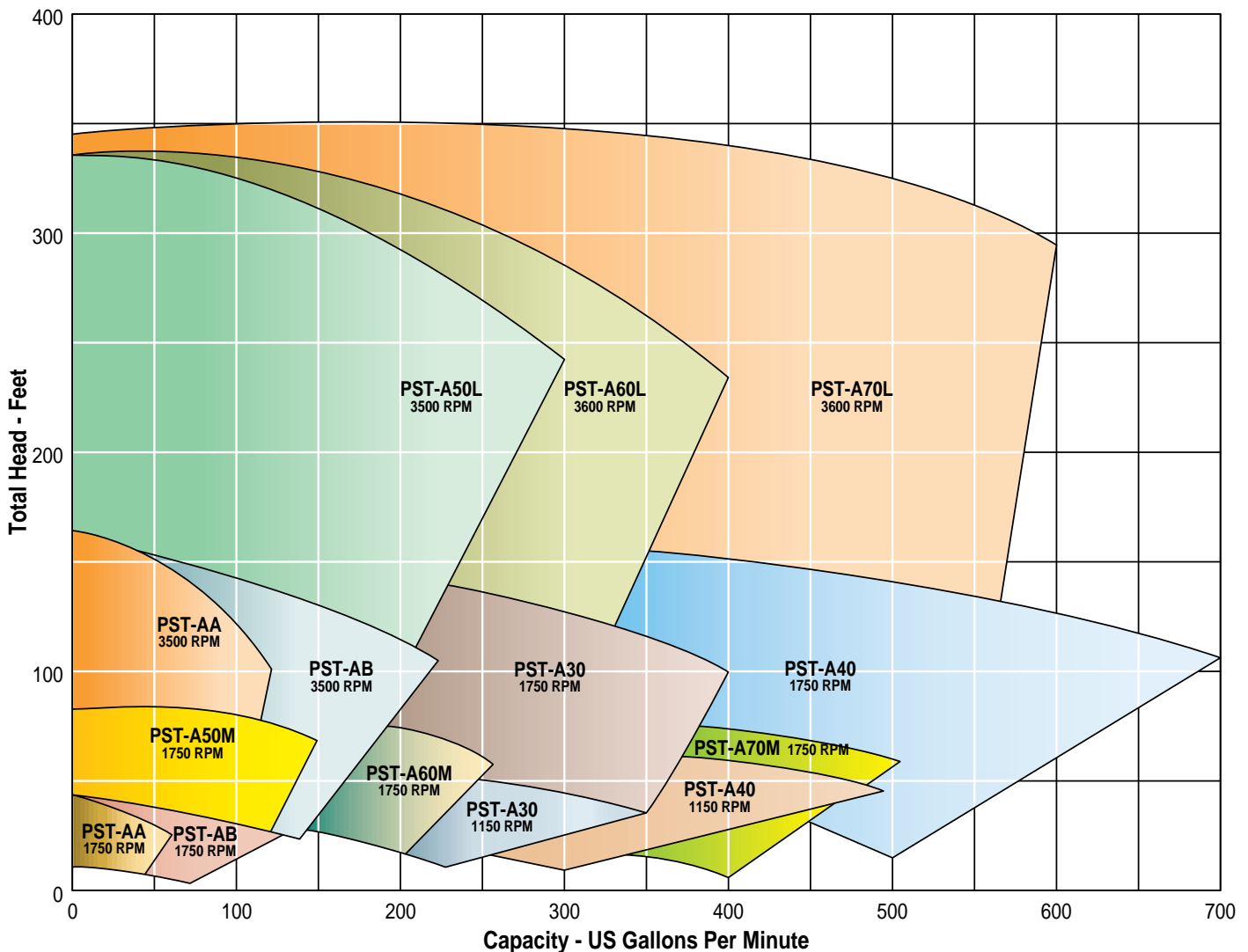

AA and AB Pump Designation

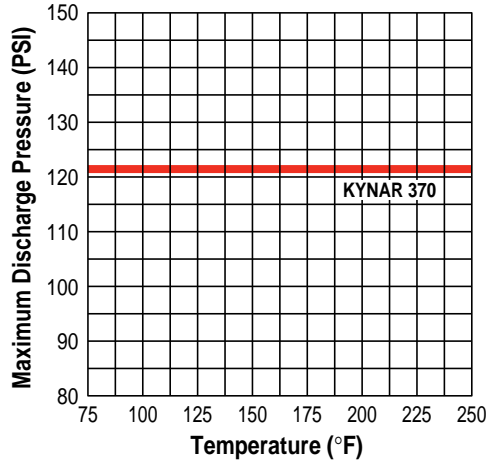

A50, A60 and A70 Pump Designation

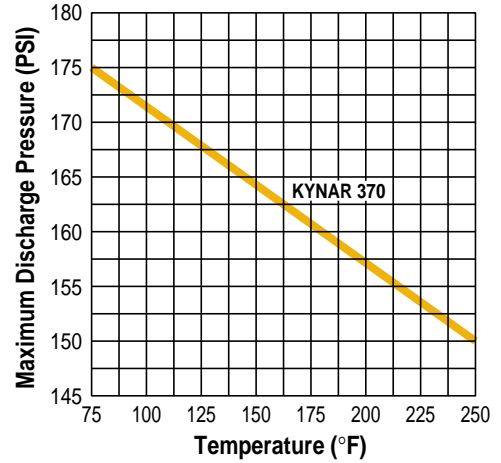

A30 and A40 Pump Designation

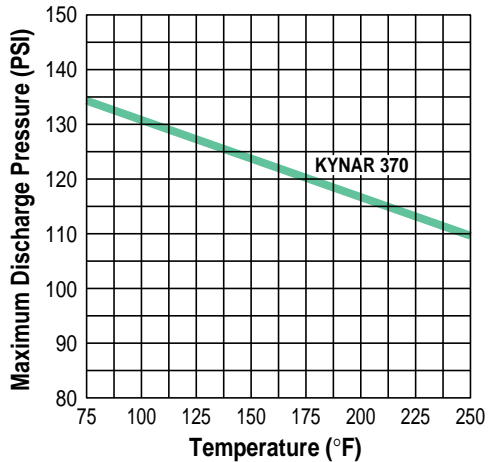

AB, A50 and A70 Pump Designation

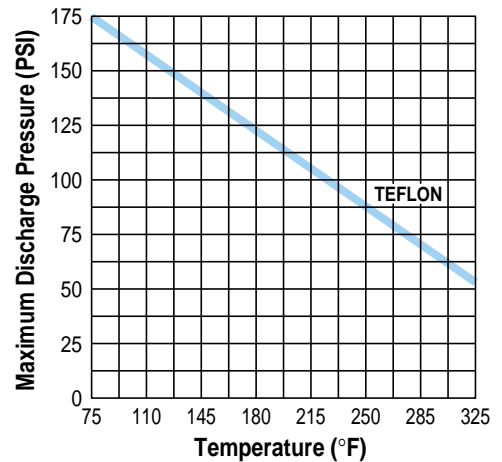

Notes:

- Maximum temperature for all Kynar 370 pumps: 250°F.
- Maximum temperature for Teflon pumps: 325°F
- For insulated pumps, multiply "maximum Discharge Pressure" by 0.8.

S P E C I F I C A T I O N S

Dimensions (inches)

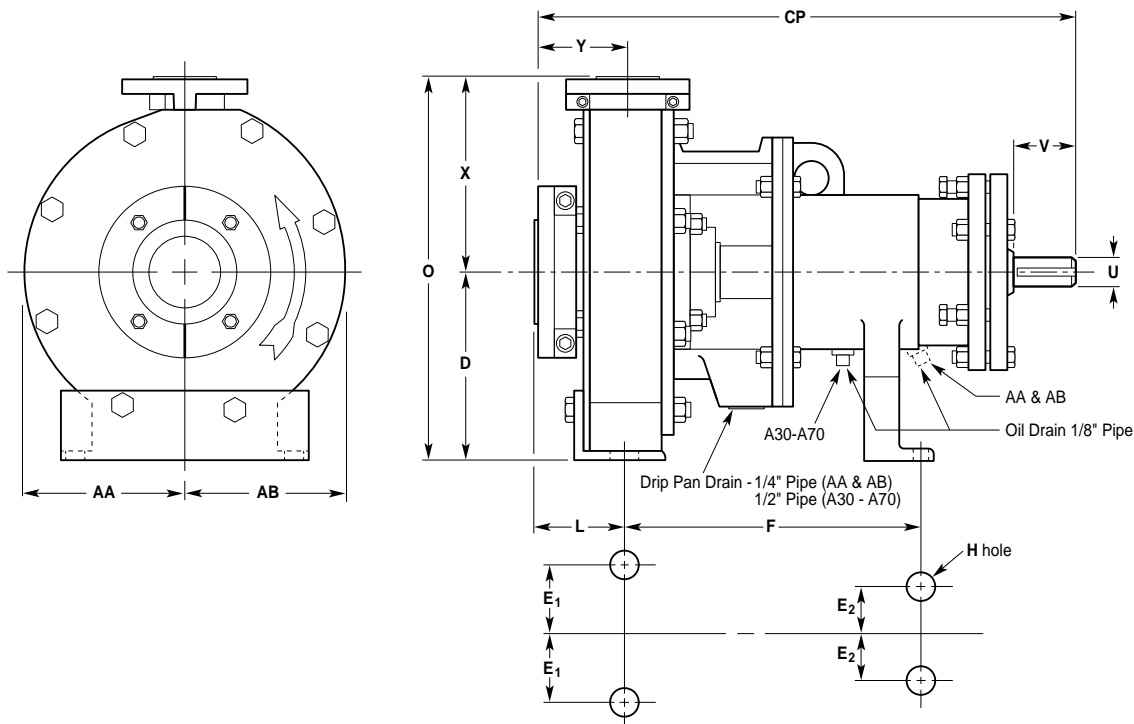

Carbon Filled Kynar 370 Pump Dimensions

Pump Designation	Pump Size	CP	D	2E ₁	2E ₂	F	H	L	Y	V (min)
AA	1-1/2 x 1 x 6	17-1/2	5-1/4	6	0	7-1/4	5/8	4	4	2
AB	3 x 1-1/2 x 6	17-1/2	5-1/4	6	0	7-1/4	5/8	4	4	2
A30	3 x 2 x 12	23-1/2	10	9-3/4	7-1/4	12-1/2	5/8	4	4	2-5/8
A40	4 x 3 x 12	23-1/2	10	9-3/4	7-1/4	12-1/2	5/8	4	4	2-5/8
A50	3 x 1-1/2 x 9	23-1/2	8-1/4	9-3/4	7-1/4	12-1/2	5/8	4	4	2-5/8
A60	3 x 2 x 9	23-1/2	8-1/4	9-3/4	7-1/4	12-1/2	5/8	4	4	2-5/8
A70	4 x 3 x 9	23-1/2	8-1/4	9-3/4	7-1/4	12-1/2	5/8	4	4	2-5/8

Pump Designation	U		O	AA	AB	X	F + L	Impeller (max)	Diameter (min)
	Diameter	Keyway							
AA	7/8	3/16 x 3/32	11-3/4	5-1/4	5-1/4	6-1/2	11-1/4	6	4
AB	7/8	3/16 x 3/32	11-3/4	5-1/4	5-1/4	6-1/2	11-1/4	6	4
A30	1-1/8	1/4 x 1/8	21-1/2	9-1/4	9-1/4	11-1/2	16-1/2	12	8
A40	1-1/8	1/4 x 1/8	22-1/2	9-1/2	9-1/2	12-1/2	16-1/2	12	8
A50	1-1/8	1/4 x 1/8	16-3/4	7-1/4	7-1/4	8-1/2	16-1/2	9	6
A60	1-1/8	1/4 x 1/8	17-3/4	7-3/4	7-3/4	9-1/2	16-1/2	9	6
A70	1-1/8	1/4 x 1/8	19-1/4	8	7-1/2	11	16-1/2	9	6

Dimensions (inches)

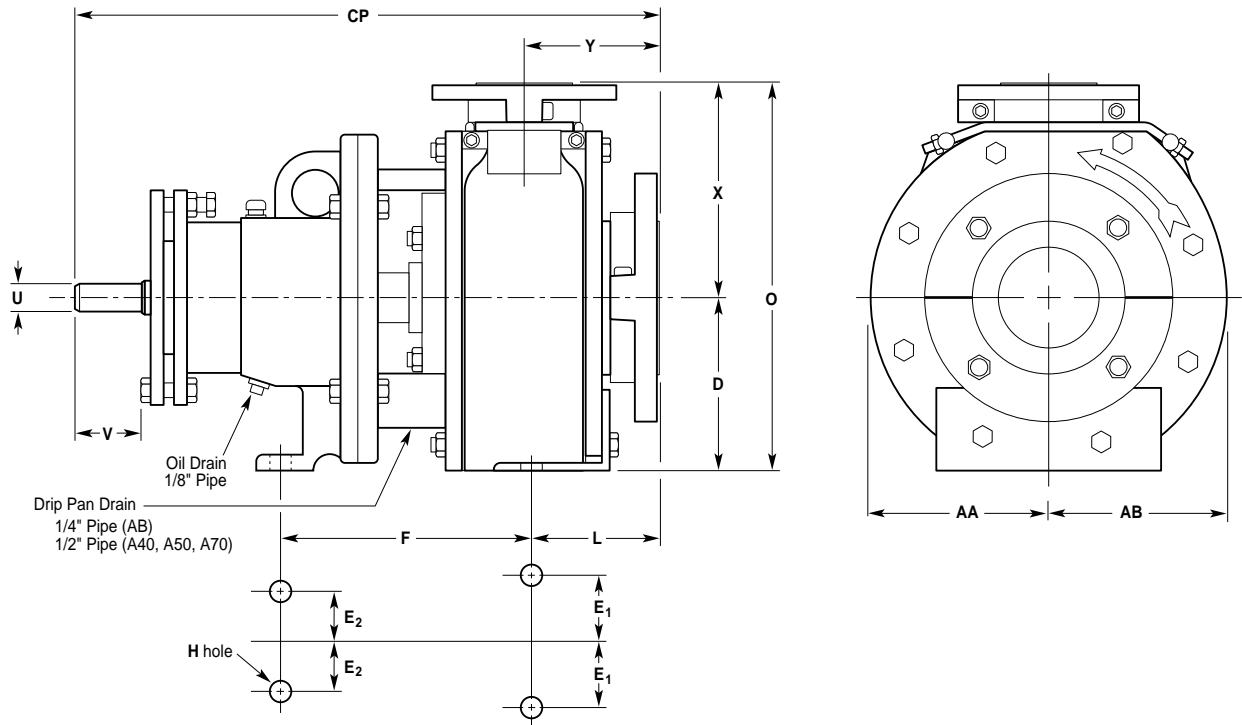

Glass Filled Teflon Pump Dimensions

Pump Designation	Pump Size	CP	D	2E ₁	2E ₂	F	H	L	Y	V (min)
AB	3 x 1-1/2 x 6	17-1/2	5-1/4	6	0	7-1/4	5/8	4	4	2
A50	3 x 1-1/2 x 9	23-1/2	8-1/4	9-3/4	7-1/4	12-1/2	5/8	4	4	2-5/8
A70	4 x 3 x 9	23-1/2	8-1/4	9-3/4	7-1/4	12-1/2	5/8	4	4	2-5/8

Pump Designation	U		O	AA	AB	Impeller X	Diameter		(max)	(min)
	Diameter	Keyway					F + L			
AB	7/8	3/16 x 3/32	11-3/4	5-1/4	5-1/4	6-1/2	11-1/4		6	4
A50	1-1/8	1/4 x 1/8	16-3/4	7-1/4	7-1/4	8-1/2	16-1/2		9	6
A70	1-1/8	1/4 x 1/8	19-1/4	8	7-1/2	11	16-1/2		9	6

Wanner Engineering **Other Pump Products**

Hydra-Cell

**Sealless, Positive
Displacement Pumps**



Designed for a broad spectrum of industrial pumping applications. For more information, contact Wanner Engineering or your local Wanner Engineering Hydra-Cell distributor for a copy of our complete catalog. Or visit our website at www.hydra-cell.com

- Pressures to 2,500 psi (172 bar)
- Flow rates to 37 GPM (140 l/min)

VECTOR

Peristaltic Pumps



Ideal for:

- High viscosity fluids
- Aggressive and corrosive fluids
- High purity solutions



Wanner Engineering, Inc.

1204 Chestnut Avenue, Minneapolis, MN 55403 USA

(612) 332-5681 FAX (612) 332-6937

Toll Free FAX (USA only) (800) 332-6812

Email: sales@wannereng.com

Website: www.wannereng.com

Document Fax Back System: (510) 745-0440



Wanner International Ltd.

Grange Court, Grange Road

Tongham, Surrey GU10 1DW, England

Tel +44 (0) 1252 781234

FAX Tel +44 (0) 1252 781235

Email: sales@wannerint.com