

SPECIFICATIONS:

MODEL NUMBER: 2088-414-634

PUMP DESIGN: Positive Displacement 3 Chamber Diaphragm Pump

Note: Pump is coated with a plastic compound for improved corrosion resistance.

CHECK VALVE: (1-Way Operation) Prevents Reverse Flow

CAM: 3.0 Degree

MOTOR: Permanent Magnet, P/N 11-185-00, Thermally Protected

VOLTAGE: 12 VDC Nominal

PRESSURE SWITCH: Splash-Proof, Adjustable from 30 to 50 PSI.

Factory Set @ 45 PSI Shut-Off, Turn On 25 PSI \pm 5 PSI

LIQUID TEMPERATURE: 130 Degrees Fahrenheit (54 Degrees Centigrade) Max.

PRIME: Self-Priming Up To 9.0 Ft. Vertical,

Max. Inlet Pressure 30 PSI (2.1 Bar)

PORTS: 1/2"-14 Male Parallel Thread

MATERIAL OF CONSTRUCTION:

PLASTICS- Polypropylene

VALVES- Santoprene

DIAPHRAGM- Santoprene

FASTENERS- Stainless Steel

NET WEIGHT: 6.0 Lbs (2.7 Kg)

DUTY CYCLE: Continuous (See Temperature Rise Chart)

TYPICAL APPLICATIONS: Washdown/Bait Tank Pump/Shallow Well

APPROVALS: U.L. Marine Listed

DIMENSIONS:

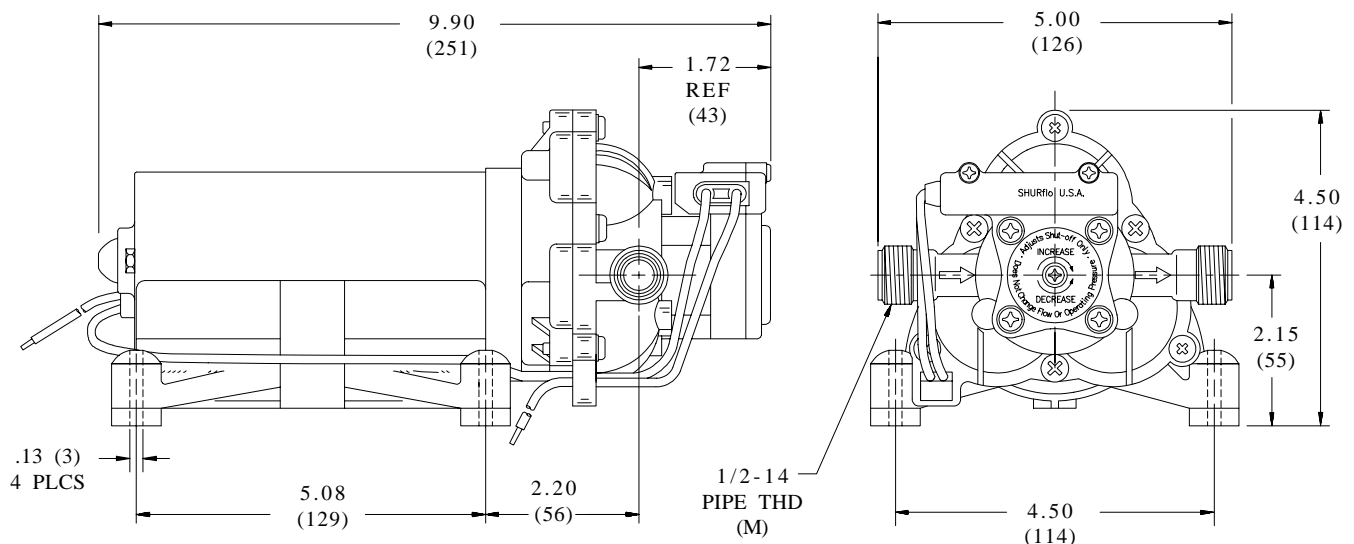

TEMPERATURE RISE

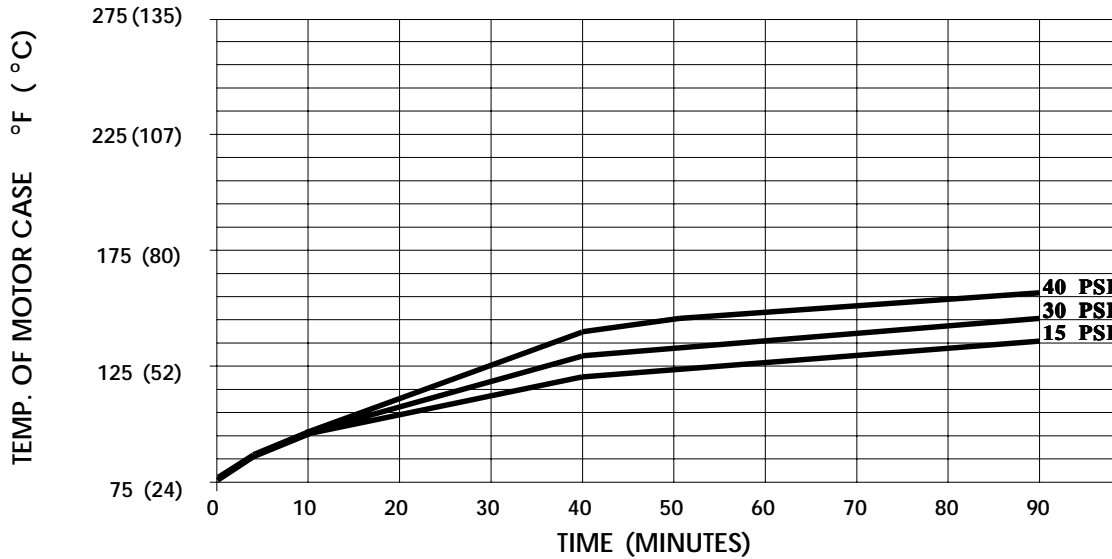

THIS GRAPH IS FOR USE AS A DESIGN GUIDE. IT IS BASED ON RUNNING CONTINUOUSLY WITH AN AMBIENT TEMPERATURE OF 75° F IN STILL AIR. THE THERMAL BREAKER WILL OPEN WHEN THE CASE TEMPERATURE REACHES 280° F.

TYPICAL PERFORMANCE

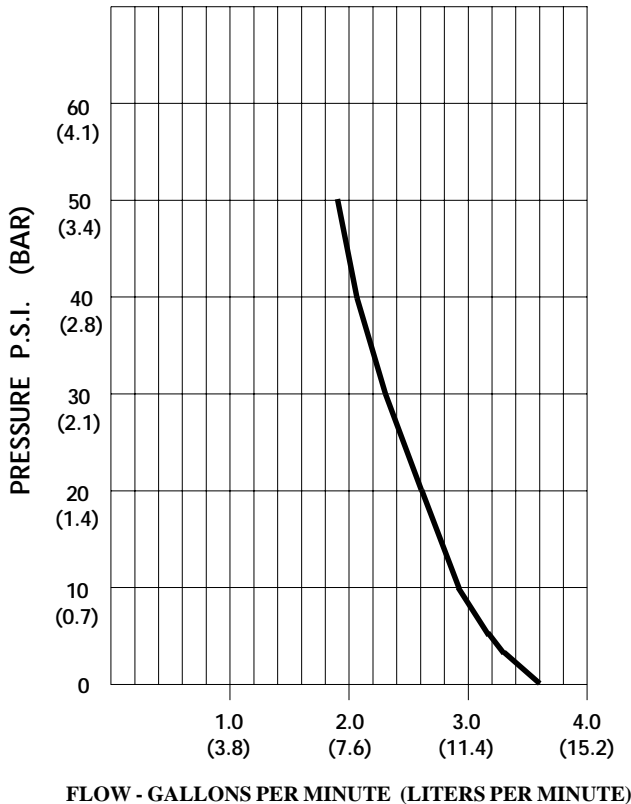

PRESSURE (PSI)	FLOW (GPM/LIT)	RPM MIN/MAX	CURRENT (AMPS)	VOLTAGE (VOLTS)
OPEN	3.60/13.6	2330/2465	4.5	12 VDC
10	2.90/11.0	2320/2460	5.6	"
20	2.60/9.8	2275/2405	7.1	"
30	2.30/8.7	2250/2365	8.4	"
40	2.07/7.8	2220/2335	9.0	"
50	1.90/7.2	2205/2315	9.5	"

*-SPECIFICATIONS SUBJECT TO CHANGE WITHOUT NOTICE.
-ALL DATA BASED ON TESTING WITH WATER.*