



## **MAG-DRIVE BAIT SENTRY**

### **Installation and Operation Instructions**

SHURflo's 12VDC Magnetic Drive Bait Sentry (MDBS) is available in three distinct flow rates relative to the capacity of the bait tank or live well. The actual pump flow rate is dependent upon plumbing losses and "head" (push or rise) from the pump to the top of the tank. It is also important to know the tanks' true "working capacity". The three sizes are: -500 suitable with tanks of 15 to 30 gallons [50-114 Lt.], -800 with tanks of 20 to 45 gallons [75-170 Lt.], and -1100 for tanks of 35 to 60 gallons [132-227 Lt.] capacity. Reference Specifications (page: 3) for proper selection.

There are various factors for determining the appropriate tank size and pump which will permit bait fish (or live well fish) to survive in the hostile environment of the tank. The amount of water in relation to the number, weight, or "scoop(s)" of bait/fish in the tank is crucial. A general recommendation is 20 gallons [75 Lt.] capacity to maintain 6 to 11 pounds [3-4.5 Kg] of bait/fish, which is usually considered a scoop.

Tank shape will affect the water currents within the tank. An ideal shape is oval. A deep tank is much better than a shallow one. Water within the tank should circulate counterclockwise at an extremely slow rate to keep the bait oriented in one direction. The tank fill tube should be positioned from top to bottom within the tank. Water must enter at the top of the tank to prevent drain back when the pump is off. A series of graduated holes or slots that allows slightly more flow at the bottom of the tank is desirable. Currents at the bottom of the tank should angle upward slightly to insure waste from the bait/fish is continually flushed from the tank. The tank drain must be four times the input tubing, as it must be able to pass the full volume entering the tank under pressure. The fresher the water in the tank, the healthier the bait/fish.

Water temperature is critical. Typically, when the water is 60°F [15°C] or less, most bait/fish will stay healthy and active. As the water temperature approaches 70°F [21°C] or above, there is less oxygen and the bait/fish become lethargic and more subject to being injured. The time that it takes to fill or change the tank will be referred to as "water turns". If a pump has too high of flow for tank capacity, water turns will be too often. Also, strong currents may cause the bait/fish to tire swiftly and die. If on the other hand, the pump flow is too low, there will not be sufficient water turns and not enough fresh oxygenated water enters the tank to flush out waste. When the water is warm (approaching 70°F [21°C]), water turns as often as 7 minutes are desirable. If the water is cooler (60°F [15°C] or less), the water turns may be up to 10 minutes apart.

With open impeller or centrifugal type pumps (such as the SHURflo MDBS), a flow-adjusting valve is an asset within the bait system. Restricting the flow actually decreases the amp draw of the motor, which will not cause damage. Use a gate or ball valve that has an opening I.D. as large as the tubing I.D. With the boat sitting in the water turn the flow-adjust valve wide open. Start the pump and note the time it takes to fill the tank. If the tank fills in less than 7 minutes, close off the valve to obtain the appropriate fill time (7 to 10 min.). If tank head/capacity was used to select the pump, the valve should only require minor adjustments to obtain the proper water turns. If a pump has too high of a flow for the tank, the valve will be almost closed in order to obtain the proper water turns. In this condition, if aerated the pump may lose prime and become airlocked.

Aeration can be a real problem in rough seas or at speed over choppy water. Under such conditions large amounts of air can continually enter into the thru-hull.

*continued on page: 2*

When the boat is moving forward at high speed, water is forced into the thru-hull fitting and pump. When a boat is moving at 30 mph [48 kph], the flow jumps to almost double! Higher speeds equal much higher flows. Flows that result in "water turns" faster than 7 minutes and are sustained for more than 20 minutes can/will cause the bait/fish harm or kill them. If your fishing involves long, high speed runs, it will be necessary to establish two flow adjust valve positions. The first setting is for stopped or low speed operation per the adjustment procedure on page 1. The second setting is for sustained high speed operation. With the tank empty, turn the flow adjust valve approximately 1/2 open. Turn on the pump and quickly accelerate to your desired "high speed". Note the time required to fill the tank. If necessary, drain the tank, reset the valve, and repeat test until a moving fill time of approximately 7 minutes is reached.

**CAUTION:** When stopped, or going slow, remember to turn the flow adjust valve **BACK** to the stopped position.

When plumbed correctly, the SHURflo MDBS can clear air trapped in the pump within a few seconds. Actual times will vary depending on system configuration. MDBS design features will cause trapped air to clear as long as the thru-hull/impeller remain flooded.

The pump's ability to clear air may be hindered by: plumbing that is horizontal or sagging below horizontal, improper sizing of the pump in relation to the tank head/capacity, or substantial back pressure due to restrictive plumbing.

The thru-hull should be located approximately 6 in. [15cm] off the center line of the keel. It **should not** be located directly in-line with any other obstructions such as water pick-ups, transducers, rivet heads, or running strakes. Such items may cause turbulence in the water resulting in a disrupted or aerated flow when the boat is moving. This simply means that air is pulled from the water and forced into the tank. This is not desirable and will rapidly kill the bait if operated under such conditions for a period of time.

**NOTES AND CAUTIONS**

1. To prevent cavitation of main drive engine, thru-hulls, transducers ,etc. should not be located in-line with the water pick up for the engine.
2. All thru-hulls **MUST** have a sea-cock shut-off valve in case of an emergency.
3. **DO NOT** use a wrench to tighten pump to the sea-cock valve. **Snug by hand only.** Properly seal all pipe threads to prevent leaks.
4. Tubing should be rated for below water-line usage. Tubing I.D. **must** be smooth wall. "Bellows" type tubing may cause as much as 50% loss in flow.
5. Always double clamp all tubing connections that are below the water line.
6. Do not cut pump wire leads. Wire connections should be made above possible bilge water level. Seal wire connections to prevent corrosion and electrolysis.

**GENERAL SAFETY PRECAUTIONS**

1. Never operate the engine or electrical equipment if fuel vapors are detected. Locate the source of the fuel vapor and properly vent.
2. When the vessel is not in use, the main power switch and sea-cock valve(s) should be **OFF/CLOSED**. However, if left afloat, the bilge pump(s) should still have power.

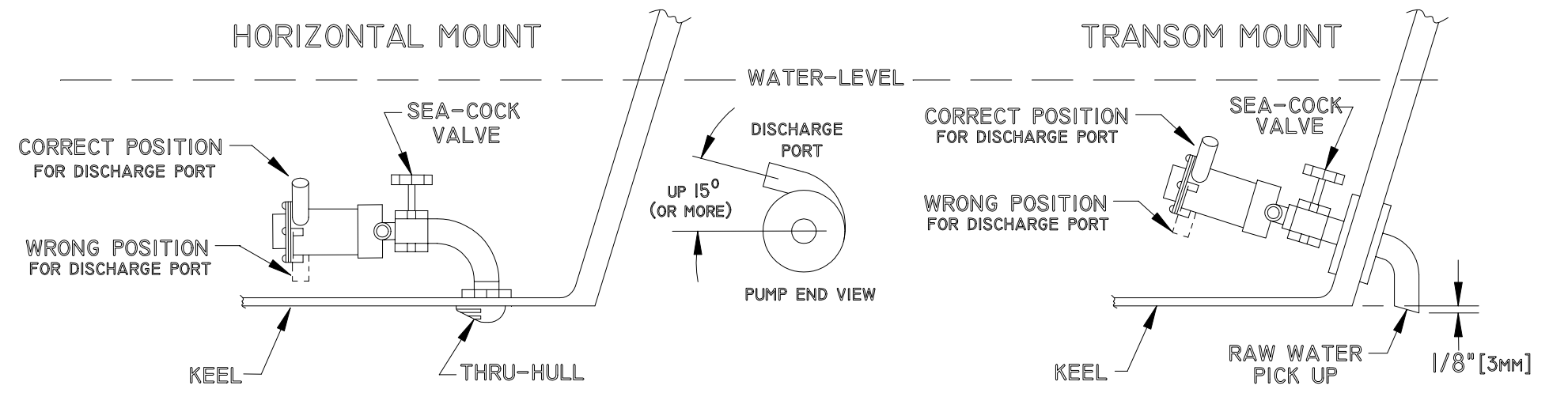
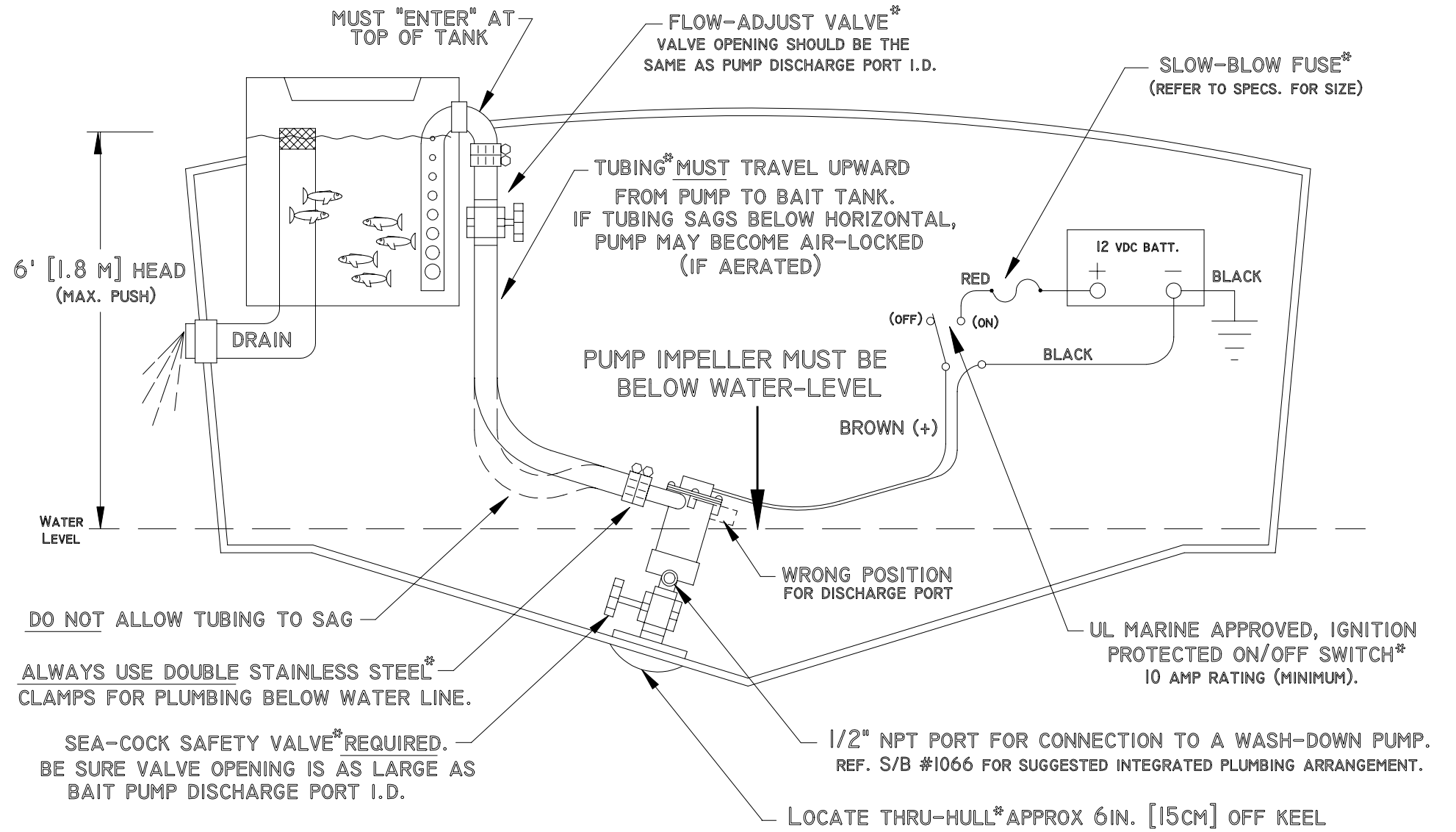

\* NOT SUPPLIED

## SPECIFICATIONS

BAIT SENTRY 1700	MAXIMUM TANK CAPACITY GAL. [LITERS] vs. HEAD w/ 7 to 10 min. FILL TIME						MAX. AMPS @12VDC	FUSE SIZE AMPS	INLET PORT M.N.P.T.	OUTLET PORT O.D.	DRY RUN HR.	DUTY CYCLE
	1 ft [30 cm]	2 ft. [60cm]	3 ft. [1M]	4 FT. [1.2M]	5 ft. [1.5 M]	6 ft. [1.8M]						
-500	30 [113]	26 [98]	20 [75]	10 [37]	—	—	1.5	2	¾"	¾"	24	CONT.
-800	40 [151]	35 [132]	29 [109]	22 [83]	11 [41]	—	2.75	4	¾"	¾"		
-1100	62 [234]	57 [215]	50 [189]	42 [158]	30 [113]	6 [22]	3.75	6	¾"	1 1/8"		

Flow rates are based on 10 ft. of total tubing from the pump to the tank at 12 VDC.

Power leads; 6 ft. [1.8 M] #18 twisted jacketed cable to minimize R.F.I. (+ BROWN; - BLACK)

Dimensions(approx.): 4 x 8 in. [10x20cm] Approx. weight: 1.85 lbs [.08kg]

## TIPS

Vibration induced by sea conditions or transportation may cause plumbing or pump hardware to loosen. Check for system components that may be loose. Many symptoms can be solved by simply tightening these components. Check the following items along with other particulars of the system:

Pump will not start, or no water	<p>Check electrical connections; fuse, switch, and ground connection. Check if voltage is present at the pump. Check for improper fuse rating or wire size.</p> <p>Sea-cock / thru-hull or valve closed. Pump above water level. Sea-cock valve not fully open. Tank flow adjust valve closed.</p>
The pump will not prime, sputters, or is air locked .	<p>Outlet tubing is sagging below horizontal or there is an air lock trap between the outlet of the pump and tank. Turn off pump, wait 5 seconds, restart. Check for debris covering the thru-hull fitting and that tubing is not plugged with debris.</p> <p>Check for debris in the pump impeller: Turn off sea-cock valve. Remove screws (4) from the top housing. Carefully remove motor/impeller assembly and o-ring. Clear debris. Reinstall o-ring and motor/impeller assembly and screws.</p>

## WINTERIZING

If the bait system and pump are subject to freezing weather, serious damage could occur to the components. It is best to completely drain the pump and all other related components. It may be necessary to remove the discharge tubing from the pump to prevent water from draining back into the pump chamber and freezing. If the boat is stored out of the water, the sea-cock valve should be open.

## LIMITED WARRANTY

SHURflo warrants its Mag-Drive Bait Sentry pumps to be free of defects in material and workmanship under normal use for a period of three (3) years from the date of manufacture indicated on the pump label. Returns are to be shipped prepaid to SHURflo. This warranty is only a representation of the complete marine products limited warranty outlined by Service Bulletin #1050. Please contact SHURflo for complete warranty information.



★ ISO Certified Facility



*SHURflo reserves the right to update specifications, prices, or make substitutions.*

### SHURflo ★

12650 Westminster Ave.  
Santa Ana, CA 92706-2100  
(800) 854-3218 (714) 554-7709  
FAX (714) 554-4721

Shipping/UPS: 12650 Westminster Ave.  
Garden Grove, CA 92843

### SHURflo East

52748 Park Six Court  
Elkhart, IN 46514-5427  
((800) 762-8094  
(219) 262-0478

FAX (219) 264-2169  
© 1998 Printed in USA

### SHURflo Ltd.

Unit 5 Sterling Park  
Gatwick Road, Crawley  
West Sussex, RH10 2QT  
United Kingdom  
+44 1293 424000  
FAX +44 1293 421880