

CLOCKWISE ROTATION  
(VIEW FROM PULLEY END)

SERVICE PART NO.	COMPONENT PART NO'S	NO. REQ'D
10577	12314	1
SEAL & SEAT	10389	1
11424	14055	1
PUMP SHAFT BEARING	13315	1

PACK WITH TEXACO BALL JOINT GREASE BETWEEN SLINGER AND BEARING BEFORE ASSEMBLING

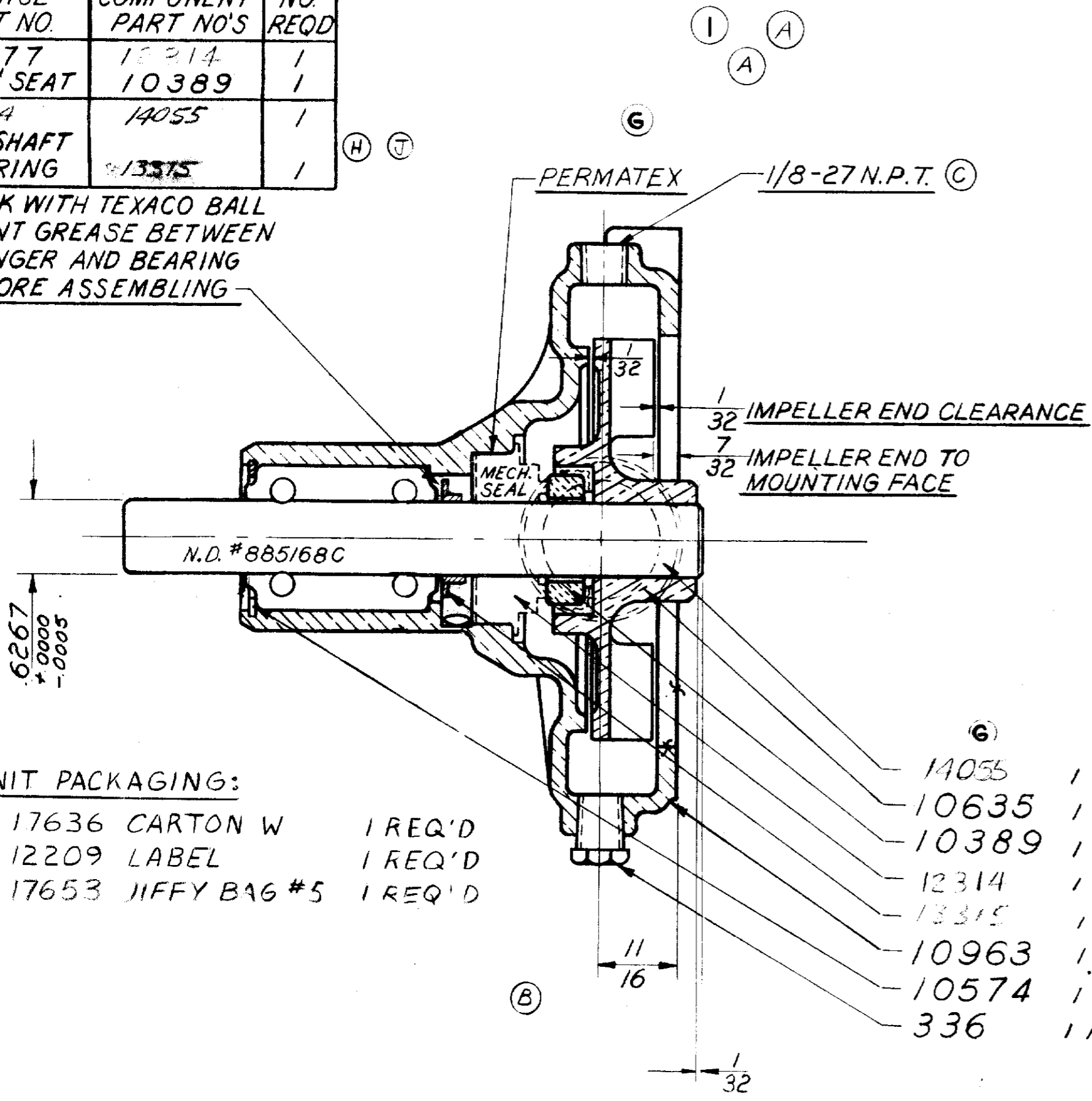

UNIT PACKAGING:

- Nº 17636 CARTON W 1 REQ'D
- 12209 LABEL 1 REQ'D
- 17653 JIFFY BAG #5 1 REQ'D

- 14055 1 REQ'D
- 10635 1 REQ'D
- 10389 1 REQ'D
- 12314 1 REQ'D
- 13315 1 REQ'D
- 10963 1 REQ'D
- 10574 1 REQ'D
- 336 1 REQ'D

CAPACITY  
30 G.P.M. EACH PORT  
15 P.S.I. @ 4000 R.P.M.

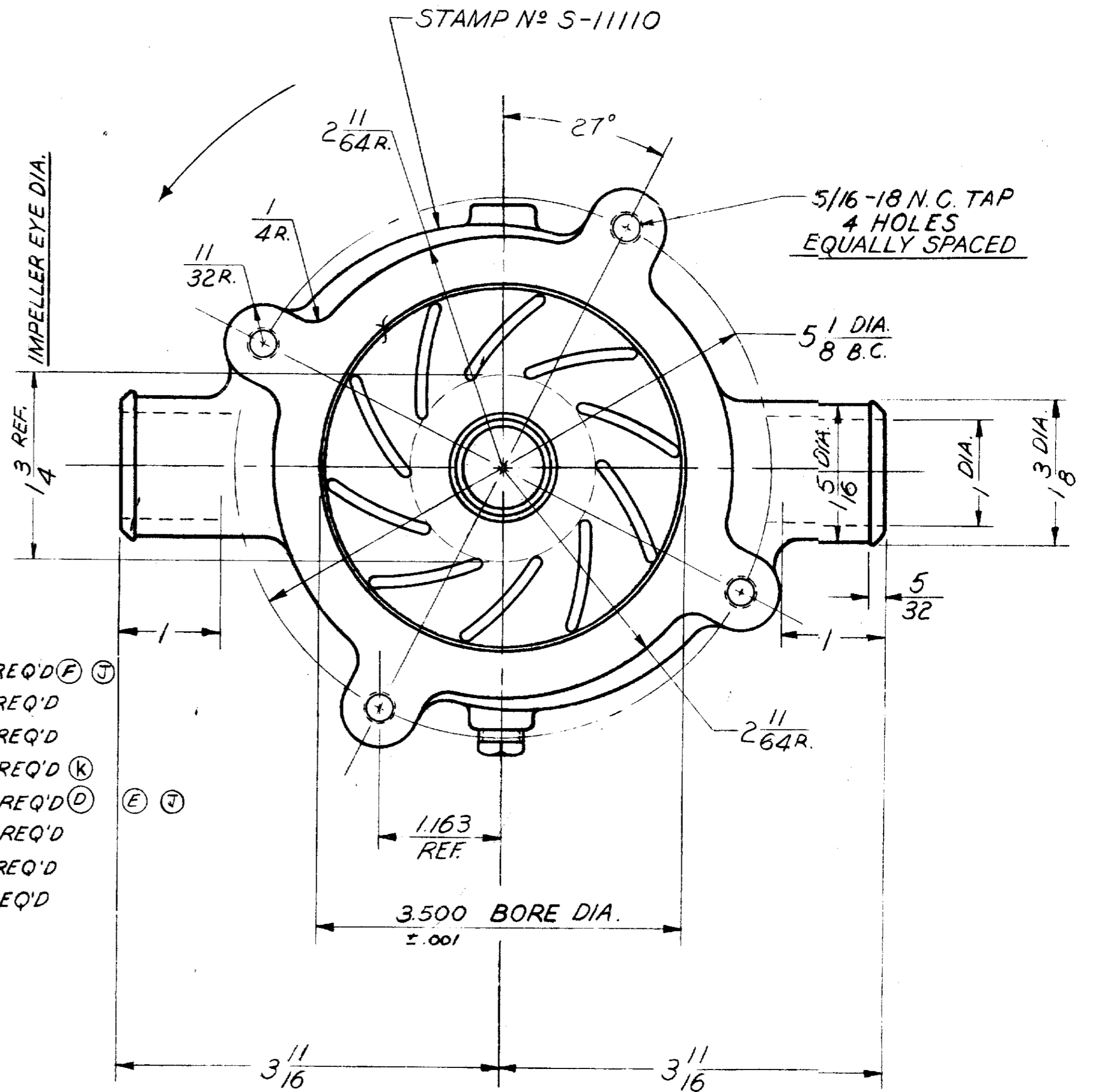

PUMP & PULLEY ASS'Y - L.H. ENGINE 06.95-07808

REV	DESCRIPTION	CKR	DATE	REV	DESCRIPTION	CKR	DATE
H	WAS Nº 10898 PUMPSHAFT ASS'Y	B.P.	4/22/68	H	WAS Nº 10898 PUMPSHAFT ASS'Y	B.P.	4/22/68
G	NºS 10859, 10636 REMOVED	B.P.	4/24/68	G	NºS 10859, 10636 REMOVED	B.P.	4/24/68
F	WAS Nº 10573 PUMPSHAFT	B.P.	4/24/68	F	WAS Nº 10573 PUMPSHAFT	B.P.	4/24/68
E	WAS Nº 11106 SLINGER	B.P.	4/24/68	E	WAS Nº 11106 SLINGER	B.P.	4/24/68
D	WAS Nº 10891 SLINGER	A.V.B.	5/12/65	D	WAS Nº 10891 SLINGER	A.V.B.	5/12/65
C	1/8 PIPE TAP ADDED	A.V.B.	3/3/65	C	1/8 PIPE TAP ADDED	A.V.B.	3/3/65
B	WAS 1 7/8 HUB LOCATION	A.V.B.	10/2/64	B	WAS 1 7/8 HUB LOCATION	A.V.B.	10/2/64
A	WAS HUB Nº 7072 AND FLANGE Nº 7074 AS FURNISHED BY CHRIS CRAFT	A.V.B.	10/2/64	A	WAS HUB Nº 7072 AND FLANGE Nº 7074 AS FURNISHED BY CHRIS CRAFT	A.V.B.	10/2/64
K	12314 WAS 8388	SH	11-12-86				
J	PUMP SHAFT BRG ASSEMBLY CHANGED	RI	10-2-86				
I	NºS N-14, 7822, AND 7824 WERE FURNISHED BY CHRIS-CRAFT AND ASSEMBLED BY SHERWOOD	PJL	5-24-69				

**SHERWOOD**  
A DIVISION OF HYPRO CORPORATION  
6331 E. JEFFERSON AVE. • DETROIT, MICHIGAN 48207

TITLE: **IMPELLER PUMP ASS'Y**

SCALE: **FULL**

DRAWN: **ERS**

CHECKED: **A.V.B.**

APPROVED: \_\_\_\_\_

DATE: **9-11-64**

DATE: **9-17-64**

DATE REF. # **D-10580**

MAT'L: **SEE DETAILS**

PART NO.: **S-11110**