

PARTS LIST

ITEM	PART NO.	DESCRIPTION	REQ'D
1	13272	SHAFT	1
2	13270	NUT - 1/2-20	1
3	13271	KEY #5 NON-ROK	1
4	4257	BEARING	2
5	6602	LIP SEAL	1
6	10514	LIP SEAL	1
7	10515	SCREW 1/4-20 X 3/8	1
8	12231	GASKET O RING	1
9	11797	SCREW 1/4-20 X 5/8	4
10	10627	CAM	1
11	11795	COVER	1
12	4432	KEY #9	1
13	9959	IMPELLER	1
14	12582	RET. RING	1
15	11794	BODY	1
16	4259	RET. RING	1
17	13273	WASHER	1

(K)
(D) (I)
(J)
(C) (O)
(M)
(L)

PACKAGING:

No 11516 PALLET	1 REQ'D
14120 TUBE CONTAINER	1 REQ'D
14122 PAD	6 REQ'D (G)
18025 INSERT	4 REQ'D

UNIT PACKAGING:

No 17636 CARTON W	1 REQ'D
12209 LABEL	1 REQ'D

(H) MAJOR REPAIR KIT NO. 12980
MINOR REPAIR KIT NO. 12981

H5

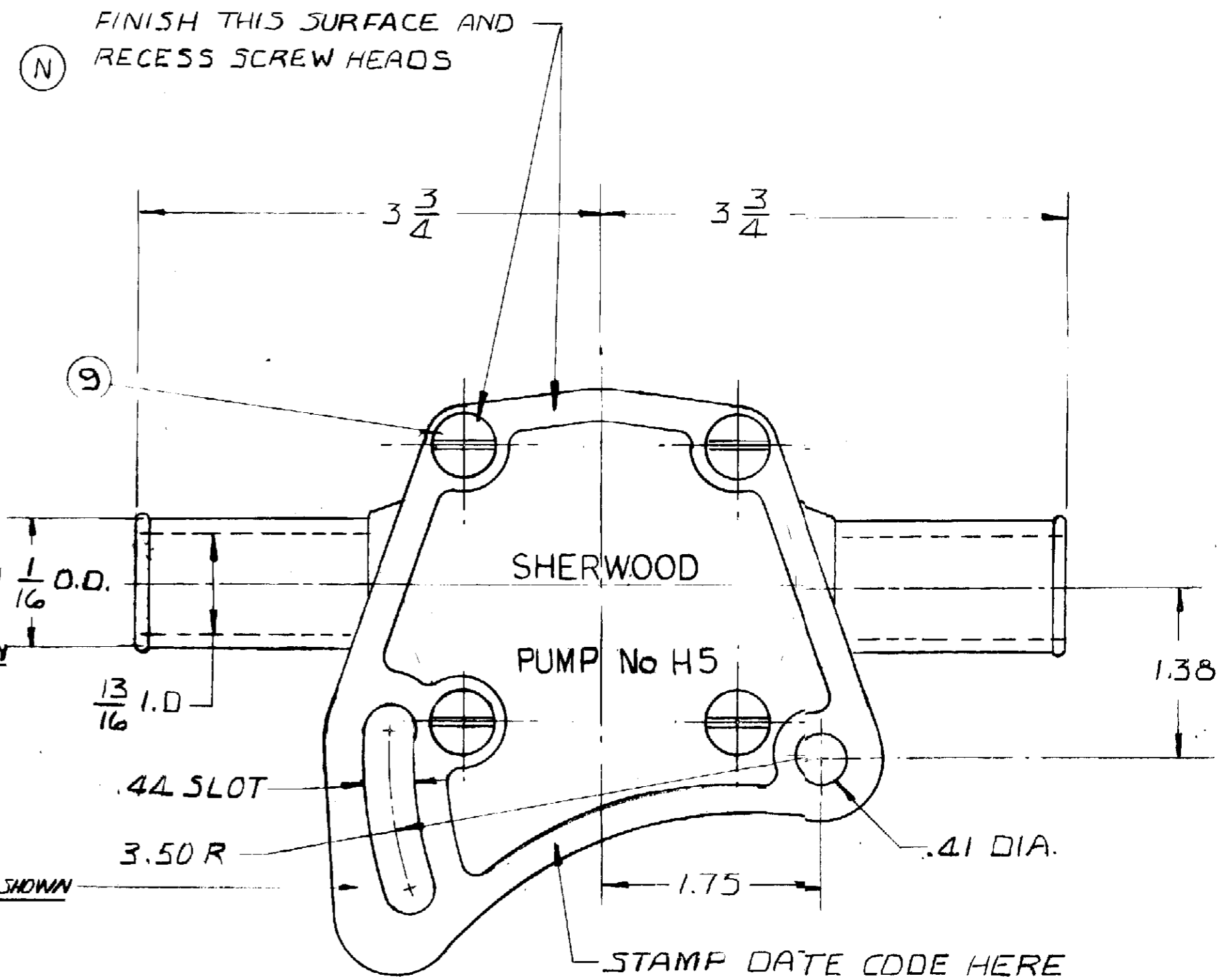
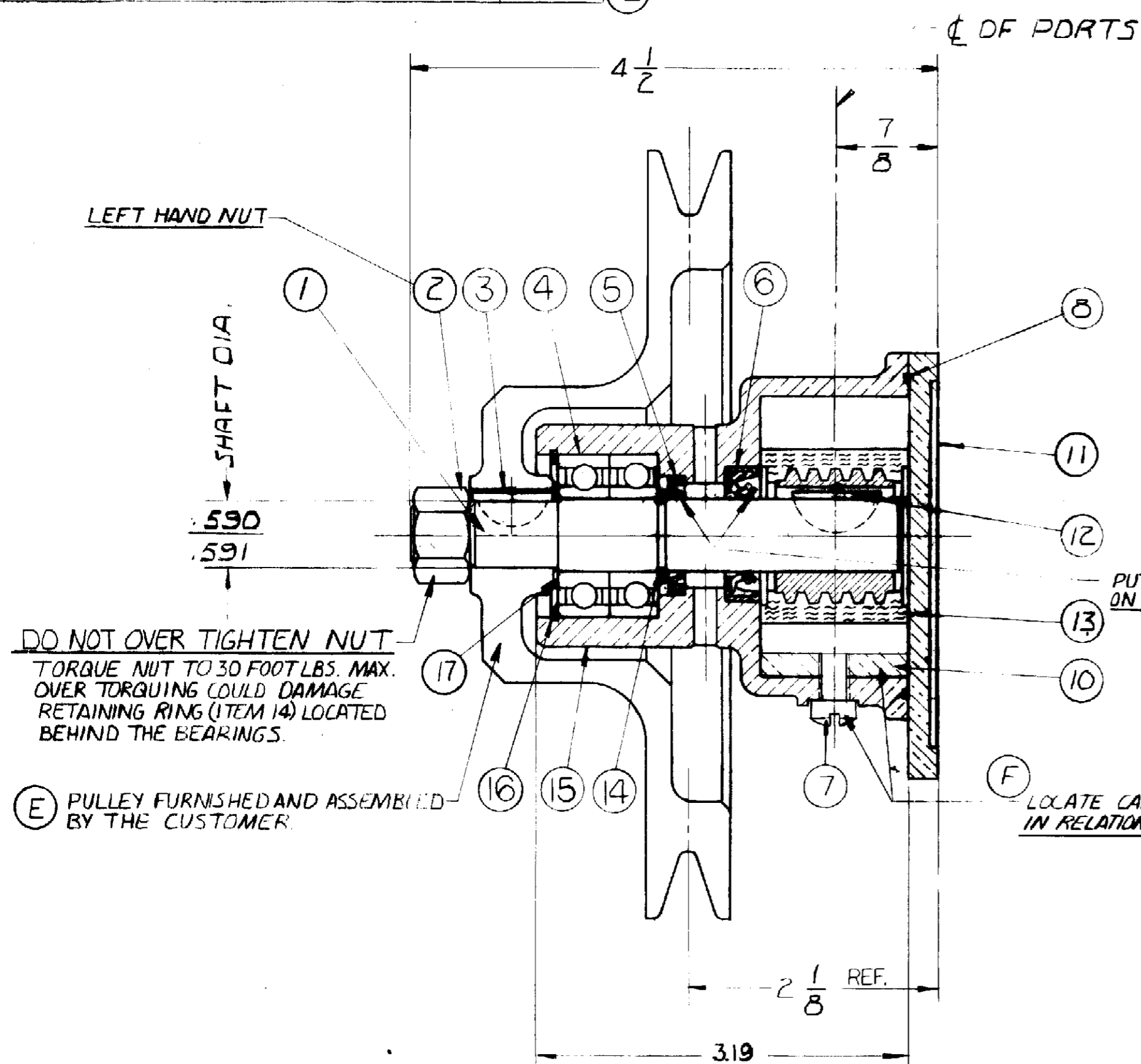

FLOW - .0068 GAL / REV.

REV	DESCRIPTION	CHKD	DATE
C	...		
N	FINISH NOTE ADDED TO COVER	RM	11-3-82
M	12582 WAS 4258	RM	12-15-80
L	13273 WASHER ADDED	RM	12-15-80
K	13272 SHAFT WAS 11796	RM	12-5-80
J	13271 KEY WAS 524		
I	13270 NUT ADDED		
H	REPAIR KITS ADDED	RM	7-29-80
G	12 PUMPS PER CARTON WAS B	RM	1-14-80
F	NOTE ADDED		
E	PULLEY ASS'Y NOTE REVISED		
D	12305 RET. RING REMOVED		
C	4257 WAS 12211. BAG.	RM	9-4-79
B	3 3/4 WAS 2 3/4	RM	6-4-79
A	REDESIGN		

CURVE NO. 79002R-79003R

UNLESS OTHERWISE SPECIFIED
TOLERANCE TO BE
CAST DIMENSION ± .020
MACHINED DIMENSION
FRACTIONAL ± .010
DECIMAL ± .005
ANGLES ± 1/2°
MACHINED SURFACE ROUGHNESS
ALLOW 1/16 STOCK ON ALL FINISHED SURFACES FOR MACHINING.
BREAK ALL SHARP EDGES .010 MAX.
CAST FILLETS AND RADIUS 1/16 R

PERKINS ENGINE INC. #NA005027

SHERWOOD
A DIVISION OF HYPRO CORPORATION
1331 E. JEFFERSON AVE. • DETROIT, MICHIGAN 48207

DRAFTSMAN	DATE	CHECKER	DATE	ASSY NO
RBM	6-21-78			

TITLE: PUMP ASSY.-RUBBER IMP.
MATERIAL: SEE DETAILS
DWG NO: H5

PROJ 195