

PARTS LIST

ITEM	PART NO.	DESCRIPTION	REQ'D
1	22796	SHAFT	1
2	13315	SLINGER	1
3	4258	EXT. RET. RING	3
4	4259	INT. RET. RING	1
5	1483	1/4 HEX. CAPSCREW	3
6	12710	1/4 LOCKWASHER	3
7	10195	CAM SCREW	1
8	18663	CAM	1
9	18451	HOUSING	1
10	18576	N#61 WOODRUFF KEY	1
11	9000	RUBBER IMPELLER	1
12	4264	FLAT WASHER	1
13	12231	O-RING GASKET	1
14	12856	END PLATE	1
15	12855	GASKET	1
16	12256	SEAL SEAT	1

17	12314	MECH. SEAL	1
18	22795	BODY	1
19	12211	BALL BEARING	2
Ⓒ 20	12859	SEAL & SEAT ASSY	SERVICE
21	22816	PART NUMBER TAG	1
Ⓓ 22	18806	LIP SEAL	1

**PACKAGING:**  
 N# 11516 PALLET 1 REQ'D  
 14120 TUBE CONTAINER 1 REQ'D  
 14122 PADS 7 REQ'D  
 14124 INSERTS 5 REQ'D  
 36 PUMPS / LAYER X 4 LAYERS = 180 PUMPS / PALLET

**UNIT PACKAGING:**  
 N# 17659 CARTON Y 1 REQ'D  
 12209 LABEL 1 REQ'D  
 17611 JIFFY BAG #1 1 REQ'D

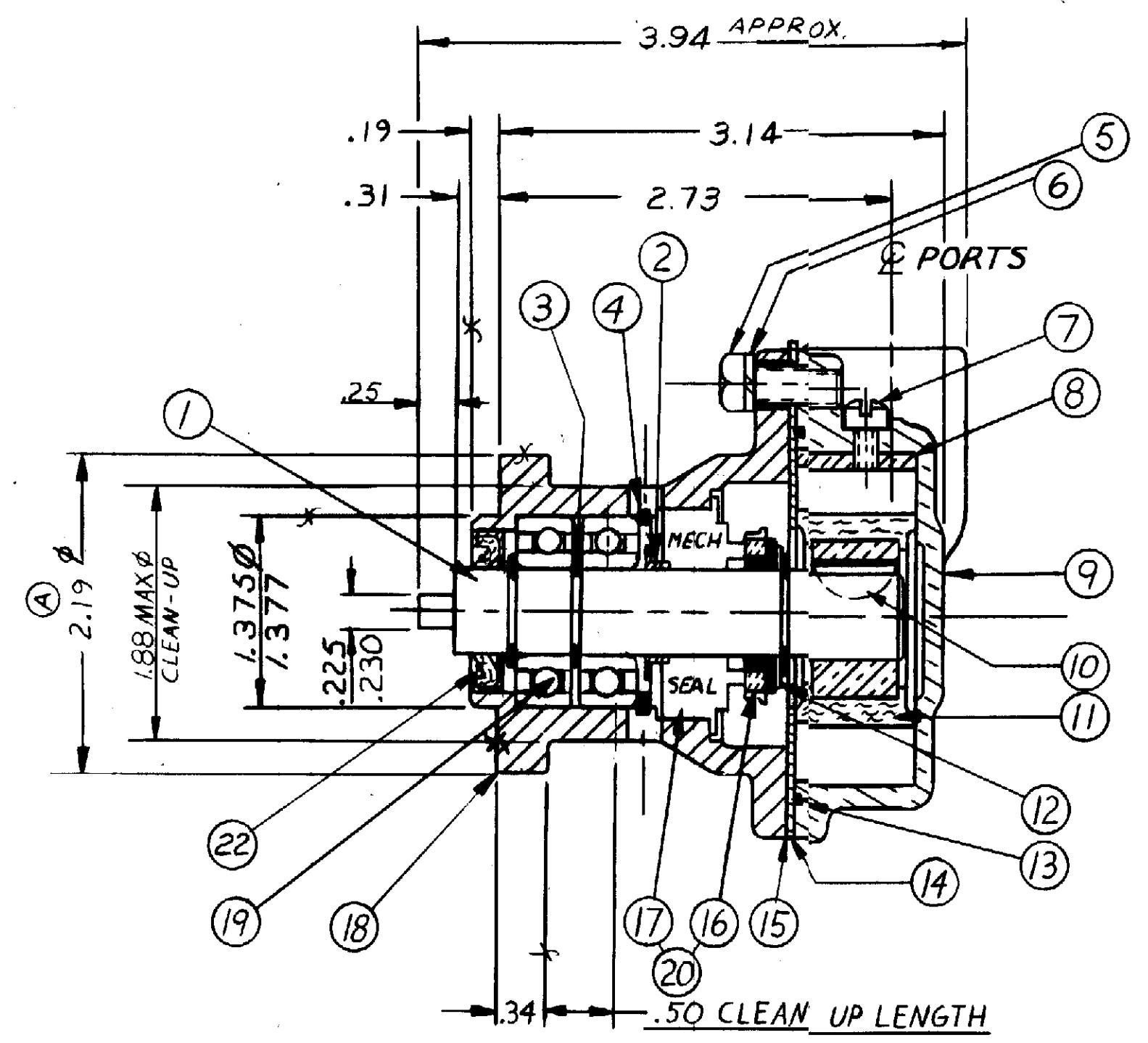
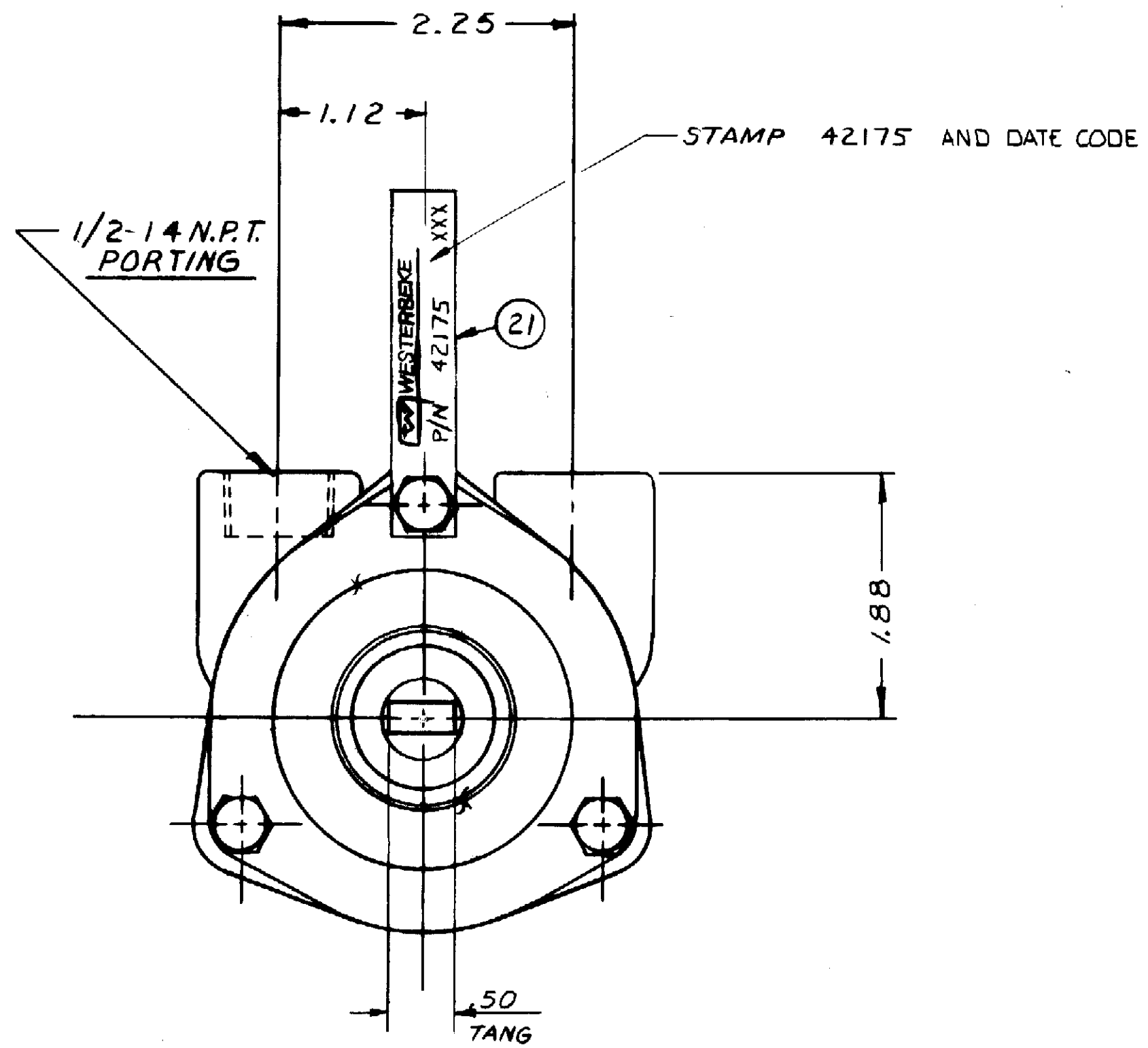

UNLESS OTHERWISE SPECIFIED CAST DIMENSIONS ± .02 FILLETS & RADII .06 FINISH STOCK .07 MACHINING TOLERANCE, INCHES XX ± .01, XXX ± .005 SURFACE ROUGHNESS ANGLES ± 0° 30' CORNER BREAKS .01 MAX. PARALLISM .001 FLATNESS .001 SQUARENESS .001 CONCENTRICITY .001 ROUNDNESS .0002 RUNOUT .001		<b>SHERWOOD</b> A DIVISION OF HYPO CORPORATION 6331 E. JEFFERSON AVE. • DETROIT, MICHIGAN 48207 DRAFTSMAN DATE CHECKER DATE PROJ. NO. KB 11/20/87 AVB 11/20/87 1251 TITLE <b>RUBBER IMPELLER PUMP ASS'Y</b> MATERIAL SEE DETAILS DWG. NO. <b>G908</b>	
REV.	DESCRIPTION	APPR	DATE