

PARTS LIST

ITEM	PART #	DESCRIPTION	REQ'D
1	21861	SHAFT	1
2	4259	INT. RET. RING	1
3	12211	BALL BEARING	2
4	21974	SPACER	1
5	4258	EXT. RET. RING	2
6	18035	MECHANICAL SEAL	1
7	10195	CAM SCREW	1
8	343	LOCKWASHER	4
9	12686	SCREW	4
10	18663	CAM	1
11	13777	KEY	1
12	19965	COVER	1
13	19964	O-RING	1
14	9000	IMPELLER	1
15	10926	SEAL SEAT	1
16	4264	WASHER	1
17	21857	THRUST WASHER	2
18	21858	3/8 LOCKNUT	1
19			
20	18573	5/16 HEX HEAD BOLT	2
21	18574	5/16 LOCKWASHER	2
22	18449	PLASTIC PIPE PLUG	2
23	14120	TUBE CONTAINER	1
24	14124	INSERT	1
25	14122	PAD	1
26	11516	PALLET	1
27	21474	SERVICE KIT	SERV.
28	21862	HOUSING	1
29			
30			
31			
32			

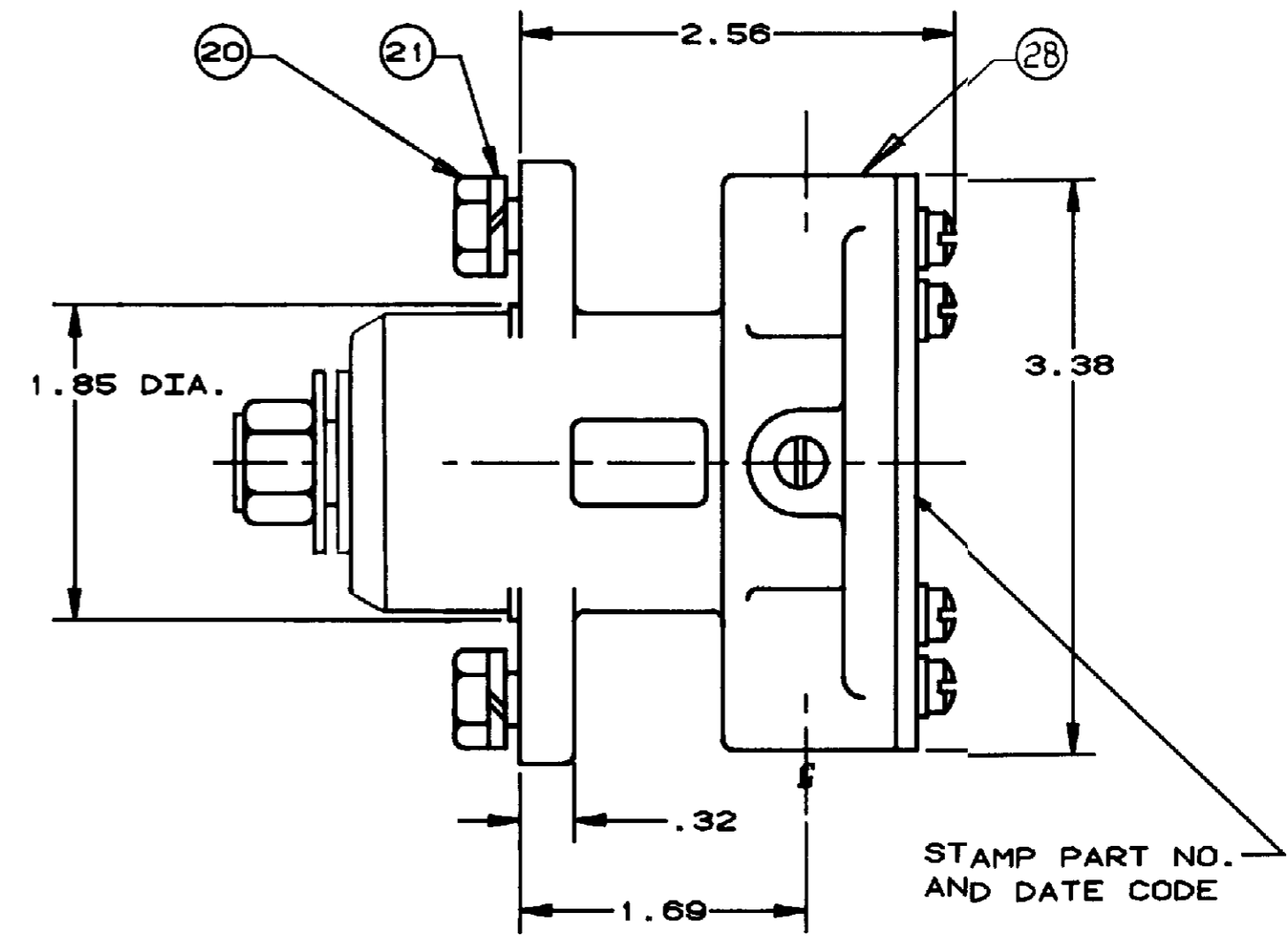

3/8-18 NPT PORTS

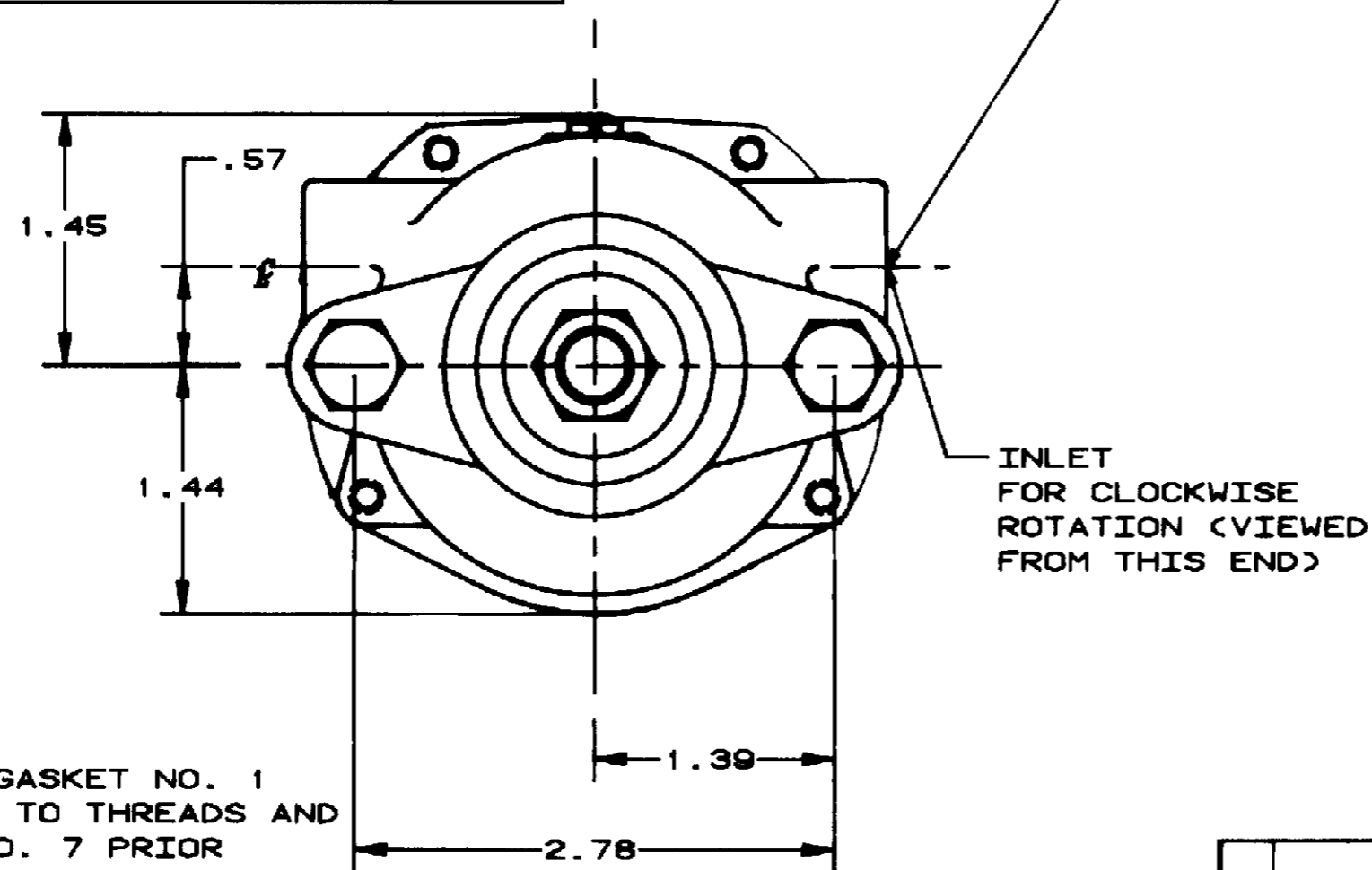

NOTES:

- 1) APPLY PERMATEx FORM-A GASKET NO. 1 (HARD SETTING) SEALANT TO THREADS AND BASE OF HEAD OF ITEM NO. 7 PRIOR TO INSTALLATION.
- 2) TIGHTEN DETAIL NO. 18 TO 15-17 FT-LBS (180-204 IN-LBS) OF TORQUE DURING INSTALLATION.

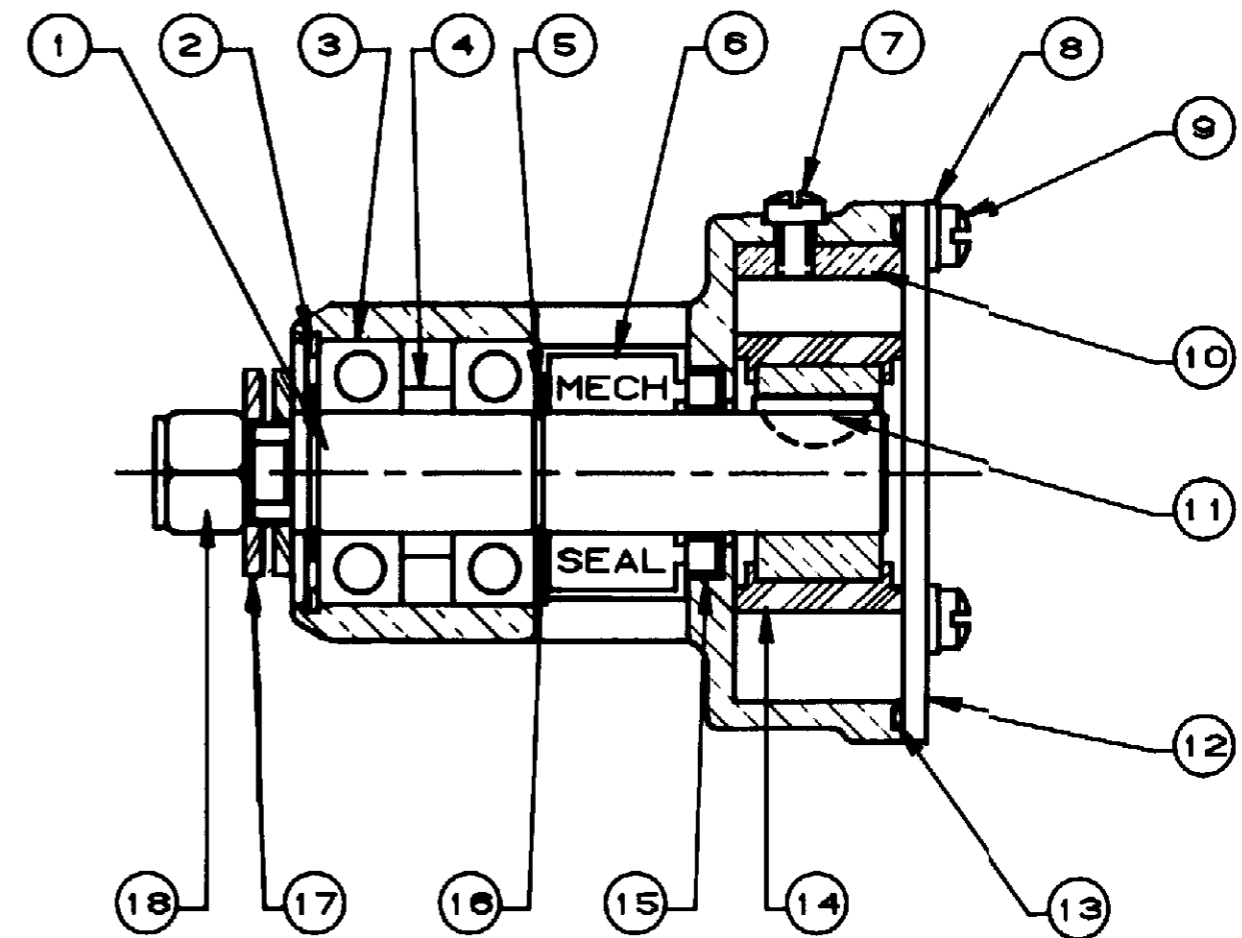

UNLESS OTHERWISE SPECIFIED		SHERWOOD	
CAST DIMENSIONS .02		A DIVISION OF HYPRO CORPORATION	
FILLETS & RADII .06		6331 E. JEFFERSON AVE. • DETROIT, MICHIGAN 48207	
FINISH STOCK .07		DRAFTSMAN	DATE
MACHINING TOLERANCE, INCHES		TLG	11-7-94
XX ± .01, XXX ± .005		CHECKER	DATE
SURFACE ROUGHNESS		ASSY NO.	
ANGLES ± 0° 30'		TITLE	
CORNER BREAKS .01 MAX		RUBBER IMPELLER PUMP	
□	FLATNESS .0015 IN/IN	MATERIAL	DWG NO.
⊥	SQUARENESS .0015	SEE DETAILS	G907
○	CONCENTRICITY .002		
○	ROUNDNESS .0005		
↺	RUNOUT .002		
REV	DESCRIPTION	APPR	DATE

PROJ. NO. 1170