

PARTS LIST

| ITEM | PART NO. | DESCRIPTION | QTY. |
|------|----------|------------------------|------|
| 01 | 21920 | BODY | 1 |
| 02 | 19869 | LIP SEAL | 1 |
| 03 | 19835 | BACK-UP WASHER | 1 |
| 04 | 21172 | M10X35 LG. FLANGE BOLT | 3 |
| 05 | 19876 | SEAL SEAT | 1 |
| 06 | 19877 | MECHANICAL SEAL | 1 |
| 07 | 19867 | INT. RET. RING | 1 |
| 08 | 19872 | BEARING | 1 |
| 09 | 19762 | EXT. RET. RING | 2 |
| 10 | 19870 | SPACER | 1 |
| 11 | 19871 | BEARING, DBL ROW | 1 |
| 12 | 19830 | SHAFT | 1 |
| 13 | 19868 | V-RING | 1 |
| 14 | 19836 | WEARPLATE | 1 |
| 15 | 19866 | BACK-UP WASHER | 1 |
| 16 | 21829 | HOUSING | 1 |
| 17 | 18000 | IMPELLER | 1 |
| 18 | 21106 | CAMLINER | 2 |
| 19 | 19837 | COVERPLATE | 1 |
| 20 | 15944 | LOCKWASHER | 13 |
| 21 | 21561 | QUAD-RING | 2 |
| 22 | 339 | HEX DRAIN PLUG | 2 |
| 23 | 19626 | M8X20 LG HEX HEAD | 3 |
| 24 | 21566 | PIN | 1 |
| 25 | 19959 | TAG | 1 |
| 26 | 21844 | PORT | 1 |
| 27 | 21830 | PORT | 1 |
| 28 | 21845 | O-RING | 1 |
| 29 | 19911 | CAM LINER SEALENT | 2 |
| 30 | 21322 | NPT PIPE CAP | A/R |
| 31 | 21319 | INSERT | 1 |
| 32 | 14122 | PADS | 2 |
| 33 | 14120 | TUBE CONTAINER | 1 |

| 34 | 21898 | BODY ASS'Y | S |
|----|-------|-------------------|---|
| 35 | 21494 | MIN. SERVICE KIT | S |
| 36 | 21855 | MAJ. SERVICE KIT | S |
| 37 | 21856 | COMP. SERVICE KIT | S |
| 38 | 19878 | SEAL ASS'Y | 1 |
| 39 | 21484 | M8X25 LG HEX HEAD | 8 |

- NOTES:
- 1) DECREASE DET. 16 AND DET. 4 PRIOR TO ASSEMBLY WITH LOCITE PRIMER 28556. COAT THREADS OF DET. 4 WITH LOCITE NO. 262(RED) OR EQUIVALENT.
 - 2) INSTALL DET. 14 WITH CRESCENT MOON SLOT POSITIONED AT THE TOP OF THE INSIDE BORE OF DET. 16.
 - 3) INSTALL O-RING DET. 21 AGAINST FLANGE ON DET. 18. APPLY A 6 mm (1/4 in.) BEAD OF CAMLINER SEALENT DET. 26 ALONG THE CENTERLINE ON THE TOP AND THE BOTTOM OF DET. 18 PRIOR TO INSTALLATION IN DET. 16.
 - 4) SHIPPING-(2) INSERTS X (9) CELLS/INSERT = (18) PUMPS/PALLET.
 - 5) INSTALL IMPELLER VANES FLIPPED AS SHOWN

TORQUE VALUES

| | |
|---------|--------------------|
| DET. 4 | 35 N.m (25 ft.-lb) |
| DET. 23 | 11 N.m (8 ft.-lb) |

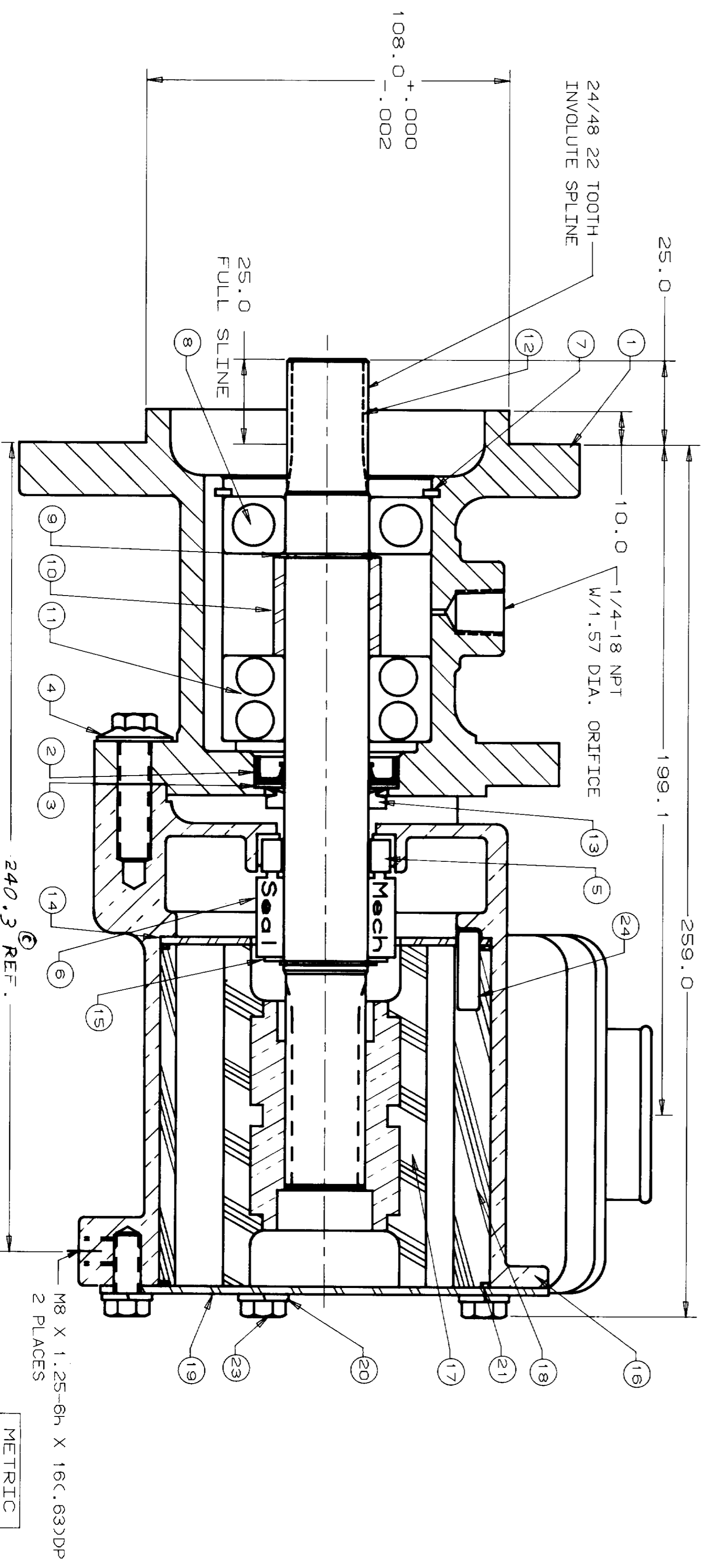
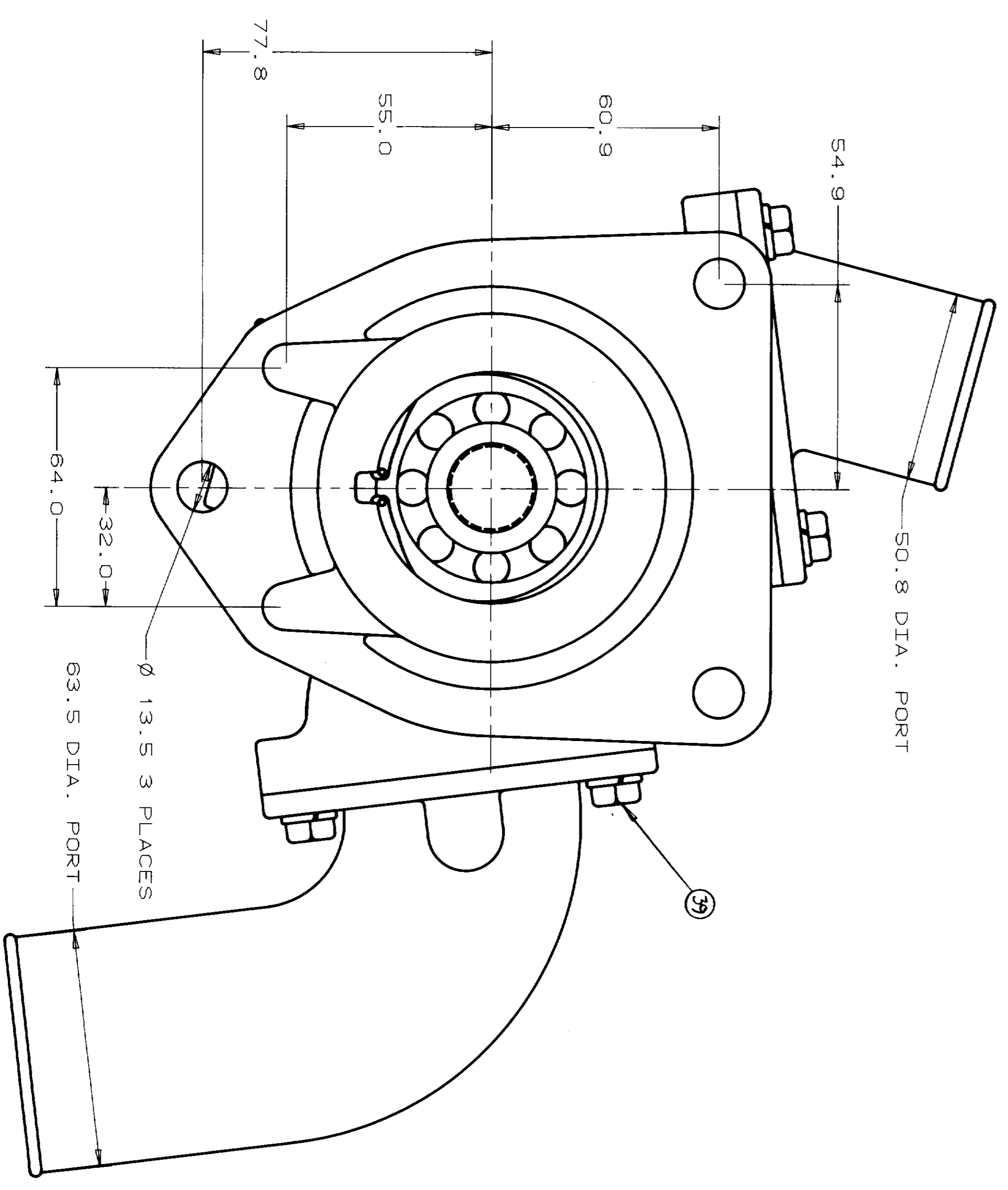
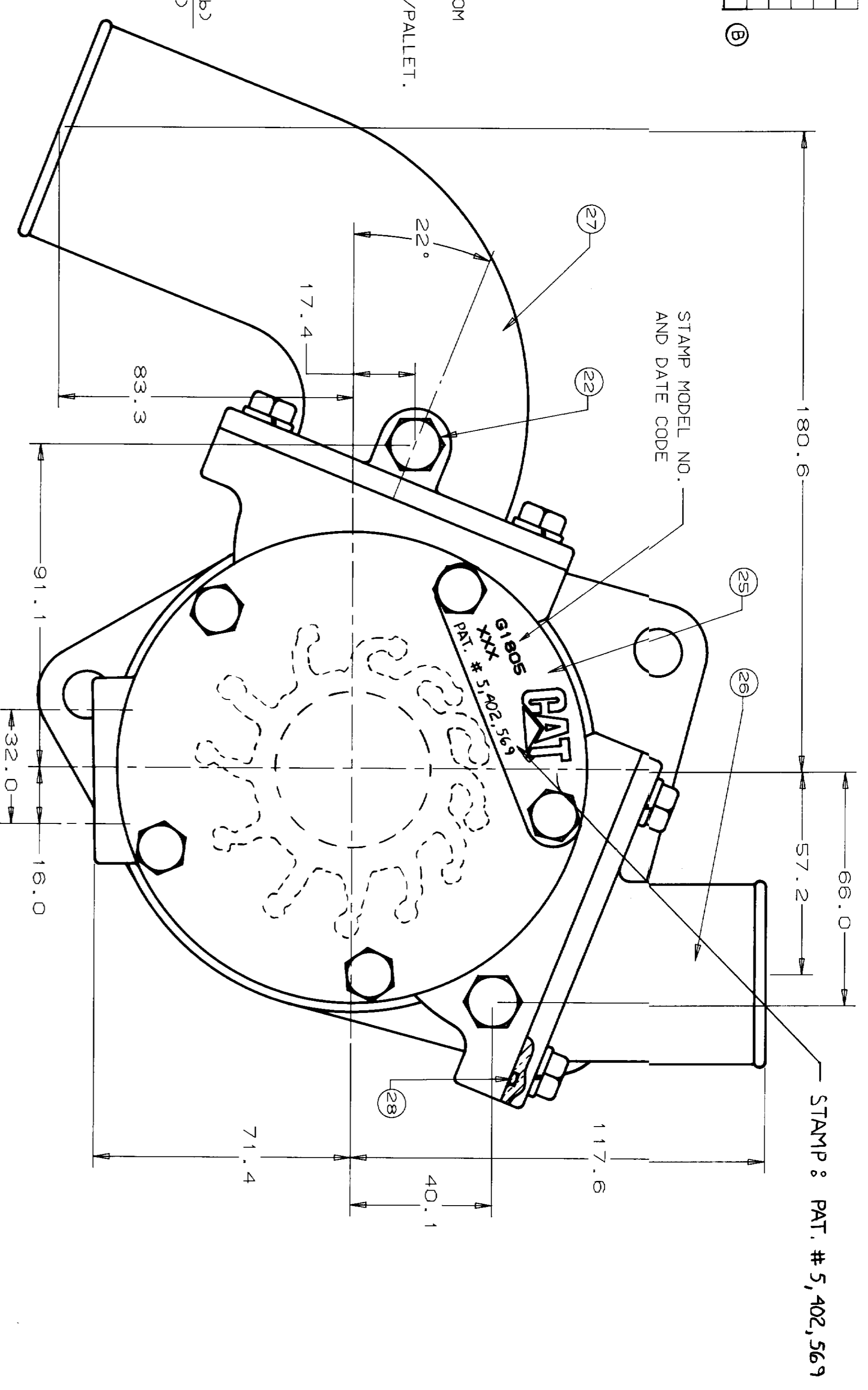

UNLESS OTHERWISE SPECIFIED

| | |
|------------------------|-------------|
| CAST DIMENSIONS | ± .02 |
| FILLET'S RADIUS | .06 |
| FILING | NO |
| MACHINING TOLERANCE | INCHES |
| XX ± .01, XXX ± .005 | |
| SURFACE ROUGHNESS | |
| CORNERS ROUNDS OR MAX. | |
| FLATNESS | 0.015 IN/IN |
| SQUARENESS | 0.015 |
| CONCENTRICITY | .002 |
| ROUNDNESS | 0.005 |
| ROUND/7.005 | |

REV. DATE DESCRIPTION

| | | | |
|---|---------|------------|-------------|
| C | W/A3 | 23.6.7 | B/M/1.6.7 |
| B | ADDED | 21484 BOLT | TLG 5/15/93 |
| A | REVISED | PRINT | TLG 11/4/94 |

TITLE: RUBBER IMPELLER PUMP
MATERIAL: SEE DETAILS
DWG NO: G1805