

17 & 18 AL, AM, AP 005-02

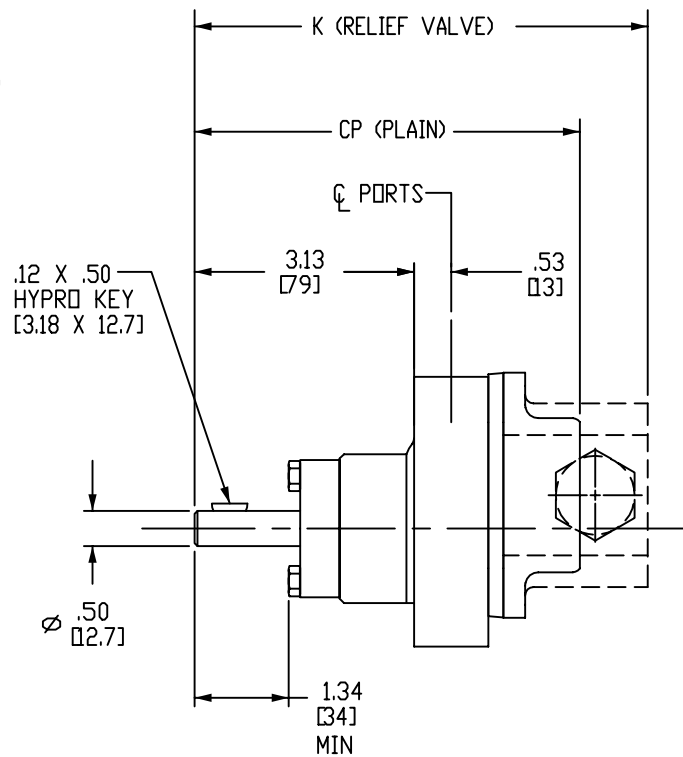

PUMP	CP	K
005	5.50 [140]	6.47 [164]
01	5.72 [145]	6.69 [170]
02	6.15 [156]	7.12 [181]

DO NOT SCALE
DIMS IN INCHES (MM)

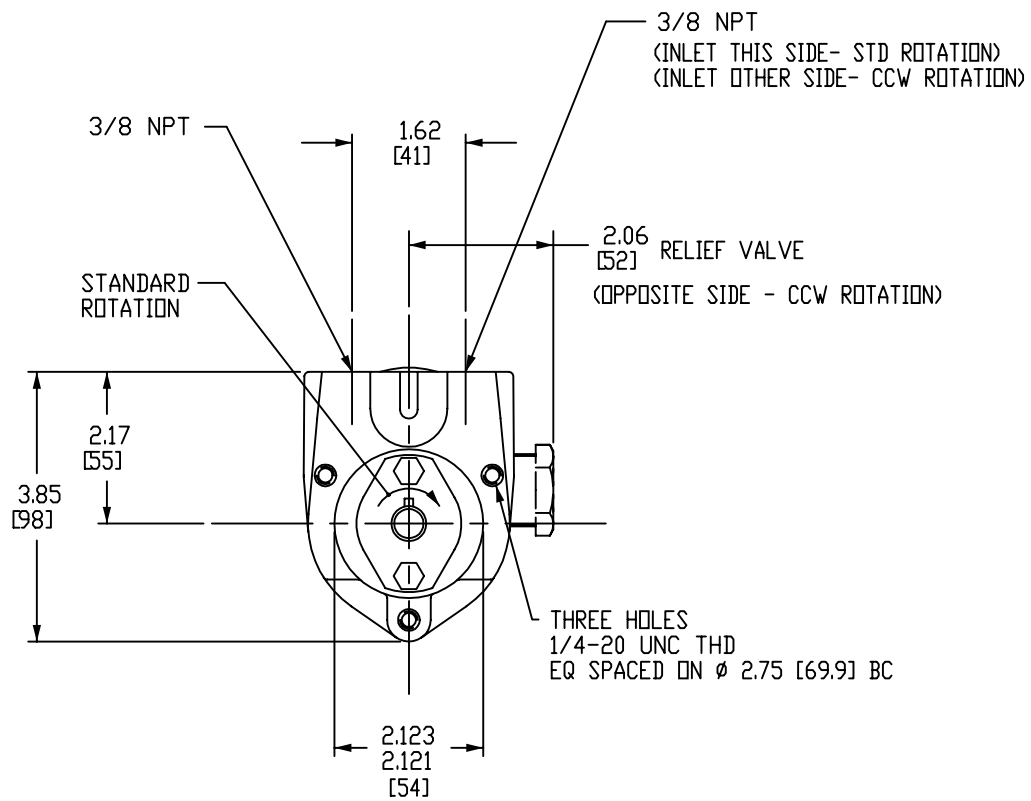
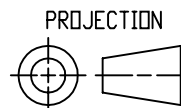

(A)

25 & 26 AL, AM, AP 005-02

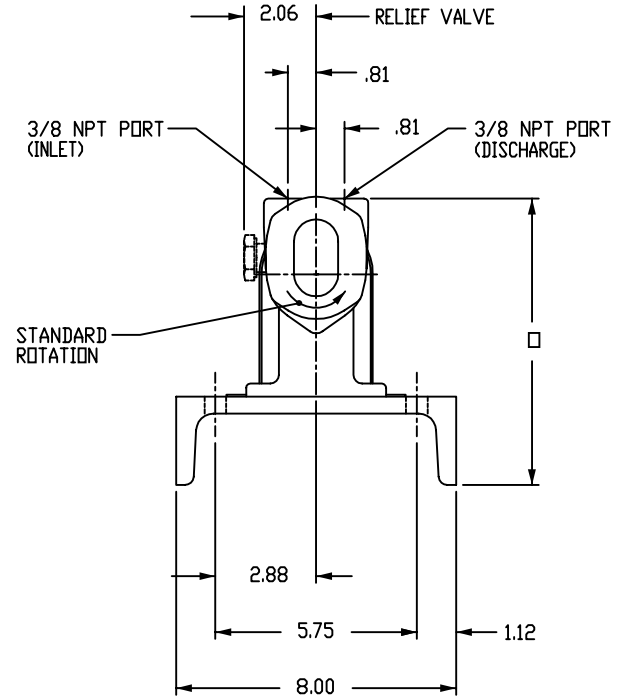
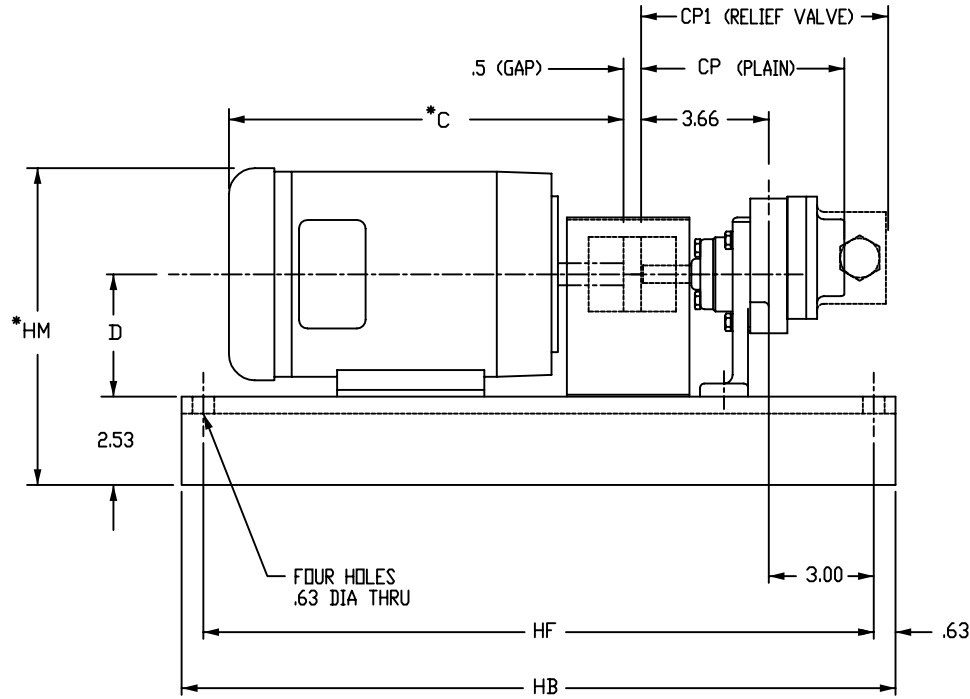

✓	PUMP	CP	K
	1 & 2 AL, AM, AP 005	5.50	6.47
	1 & 2 AL, AM, AP 01	5.72	6.69
	1 & 2 AL, AM, AP 02	6.15	7.12

✓	MOTOR FRAME	*MOTOR WEIGHT	BASE/CPLG/HDWRE WT	*C	D	HB	HF	*HM	□
	48	22	38	9.31	3.0	18	16.75	8.41	6.81
	56	34	47	12.31	3.5	24	22.75	9.41	7.31
	143T	58		12.56					
	145T	65		12.82					

✓ = UNIT SELECTED

DIMENSIONS IN INCHES
WEIGHTS IN POUNDS

* DIMENSIONS AND MOTOR WEIGHTS WILL VARY BASED ON MOTOR MANUFACTURER AND TYPE. CHART DIMENSIONS AND MOTOR WEIGHTS BASED ON TEFC 3 PHASE MOTORS.

RV = RELIEF VALVE

LOVEJOY COUPLINGS STANDARD
APPROXIMATE PUMP WEIGHT = 8 LBS



ROPER PUMP COMPANY
P.O. BOX 269
3475 OLD MAYSVILLE RD
COMMERCE, GEORGIA 30529 U.S.A.

TELEPHONE: (706) 335-5551
TELEFAX: (706) 335-5505

DATE: _____

PUMP NO.: _____

ROPER NO.: _____

CUSTOMER: _____

CUSTOMER NO.: _____

SERVICE: _____

33 & 34 AL, AM, AP 005-02

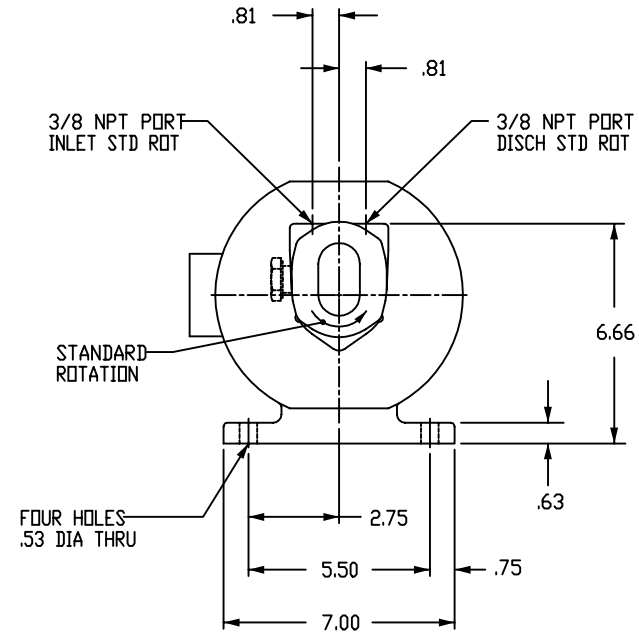
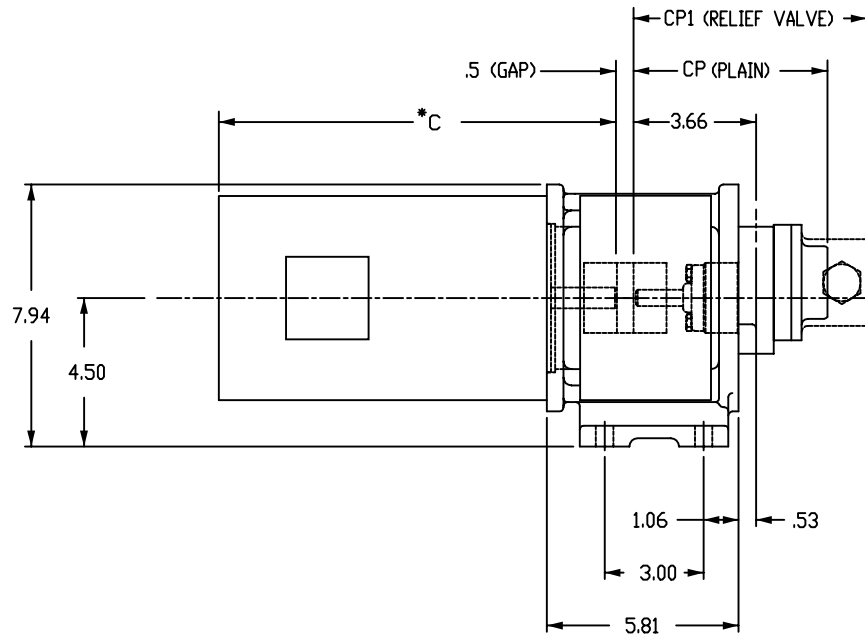

✓	PUMP SIZE	PUMP WEIGHT	CP	CP1
	005	5.5	5.50	6.47
	01	6	5.72	6.69
	02	6.5	6.15	7.12

✓	MOTOR FRAME	*MOTOR WEIGHT	BRACKET/CPLG/HDWRE WT	*C
	48CΔ	22	38	9.31
	56C	34	47	12.31
	143TC	58		12.56
	145TC	65		12.82

Δ NEMA FRAME 48C WITH 56C MOUNTING



ROPER PUMP COMPANY
 P.O. BOX 269
 3475 OLD MAYSVILLE RD
 COMMERCE, GEORGIA 30529 U.S.A.

TELEPHONE: (706) 335-5551
 TELEFAX: (706) 335-5505

✓ = UNIT SELECTED

DIMENSIONS IN INCHES
 WEIGHTS IN POUNDS

* DIMENSIONS AND MOTOR WEIGHTS WILL VARY BASED ON MOTOR MANUFACTURER AND TYPE. CHART DIMENSIONS AND MOTOR WEIGHTS BASED ON TEFC 3 PHASE MOTORS.

RV = RELIEF VALVE

LOVEJOY COUPLINGS STANDARD

DATE: _____

PUMP NO.: _____

ROPER NO.: _____

CUSTOMER: _____

CUSTOMER NO.: _____

SERVICE: _____

33 & 34 AL, AM, AP 005-02

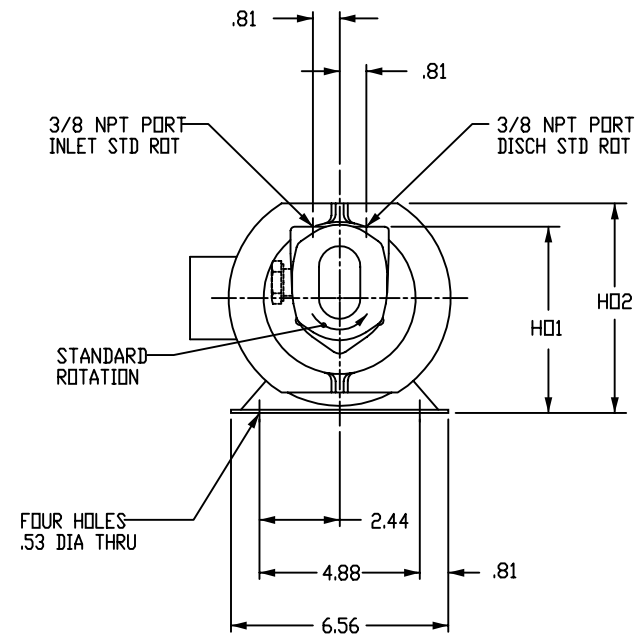
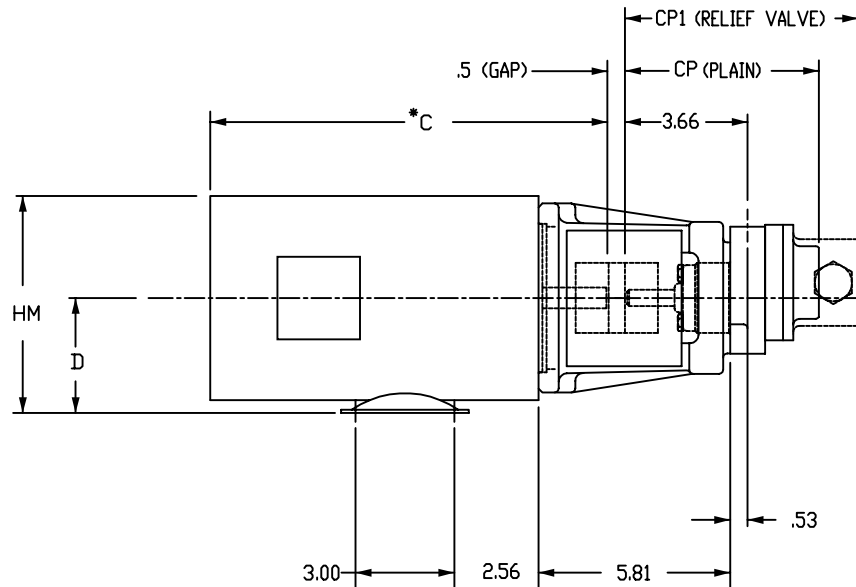

✓	PUMP SIZE	PUMP WEIGHT	CP	CP1
	005	5.5	5.50	6.47
	01	6	5.72	6.69
	02	6.5	6.15	7.12

✓	MOTOR FRAME	*MOTOR WEIGHT	BRACKET/CPLG/HDWRE WT	*C	D	HM	HQ1	HQ2
	48C△	22	38	9.31	3.00	5.88	5.16	5.88
	56C	34	47	12.31	3.50	6.94	5.66	6.38
	143TC	58		12.56				
	145TC	65		12.82				

△ NEMA FRAME 48C WITH 56C MOUNTING

✓ = UNIT SELECTED
 DIMENSIONS IN INCHES
 WEIGHTS IN POUNDS
 * DIMENSIONS AND MOTOR WEIGHTS WILL VARY BASED ON MOTOR MANUFACTURER AND TYPE. CHART DIMENSIONS AND MOTOR WEIGHTS BASED ON TEFC 3 PHASE MOTORS.
 RV = RELIEF VALVE
 LOVEJOY COUPLINGS STANDARD



ROPER PUMP COMPANY
 P.O. BOX 269
 3475 OLD MAYSVILLE RD
 COMMERCE, GEORGIA 30529 U.S.A.

TELEPHONE: (706) 335-5551
 TELEFAX: (706) 335-5505

DATE: _____
 PUMP NO.: _____
 ROPER NO.: _____
 CUSTOMER: _____
 CUSTOMER NO.: _____
 SERVICE: _____

1 & 2 AL, AM, AP 03

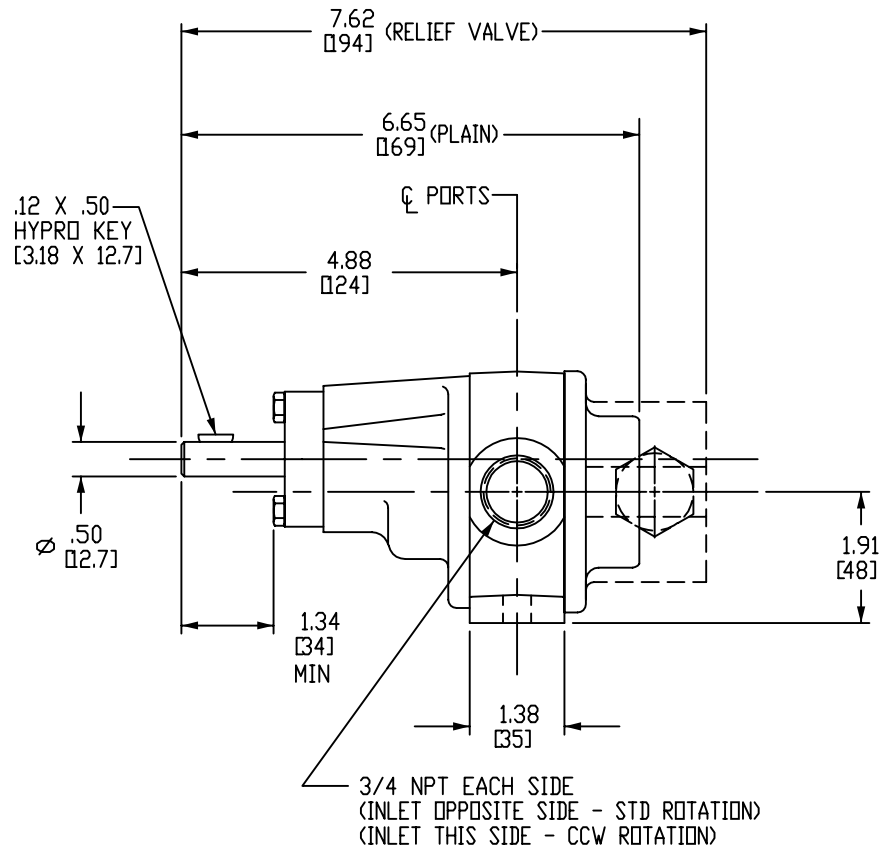
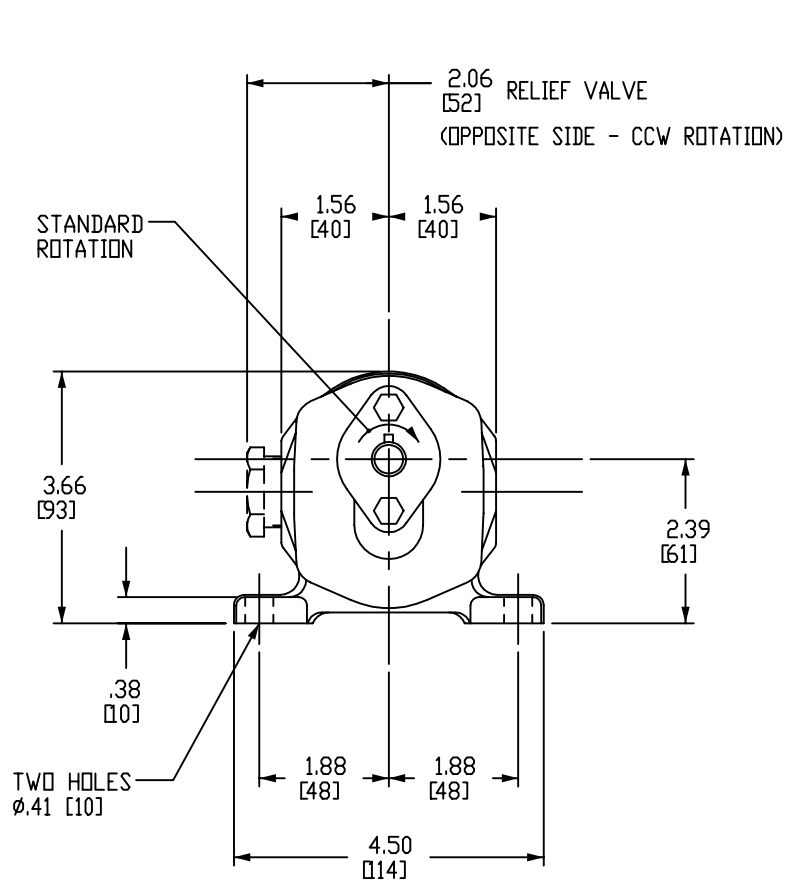

DO NOT SCALE
DIMS IN INCHES [MM]

PROJECTION

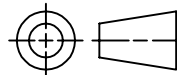

17 & 18 AL, AM, AP 03

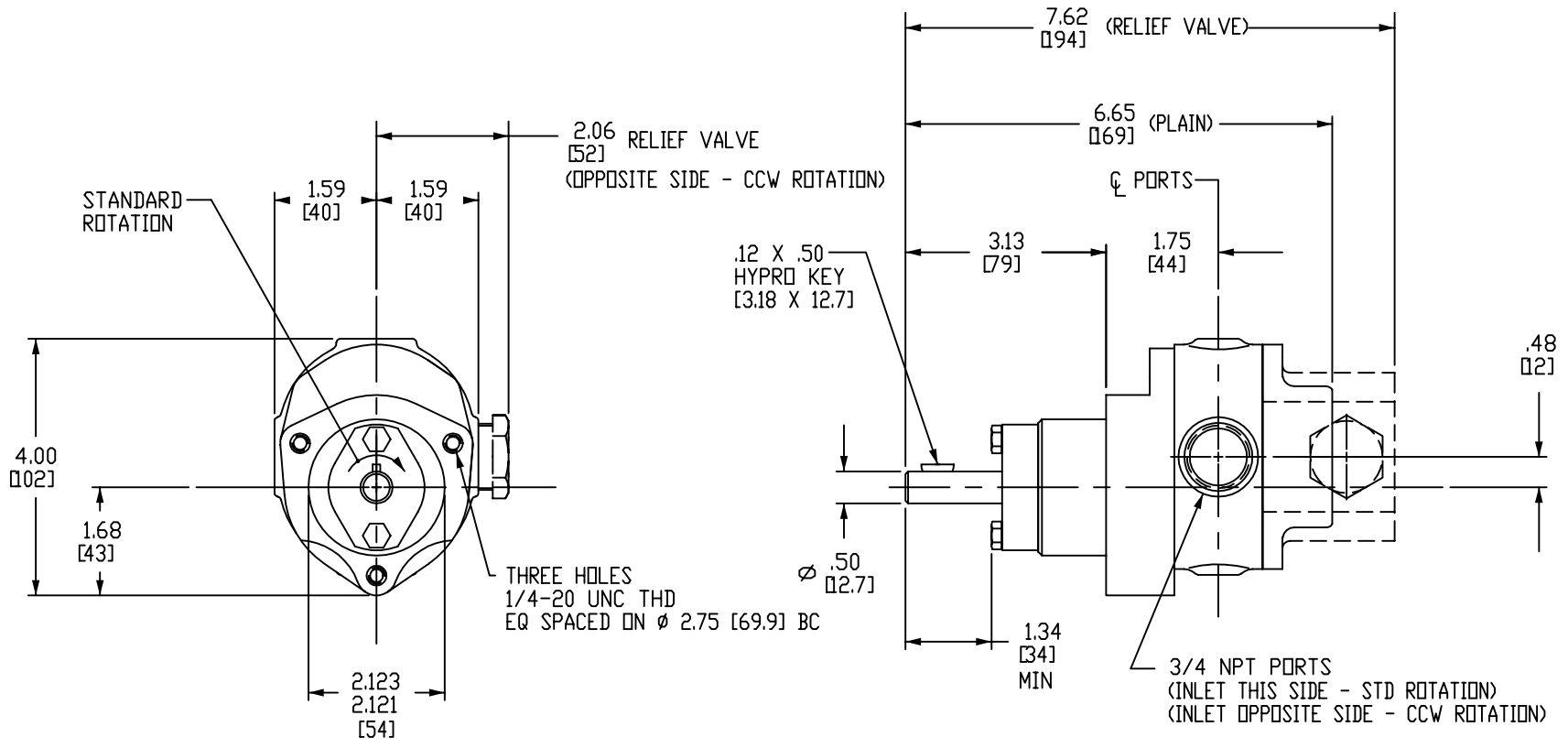

DO NOT SCALE
DIMS IN INCHES [MM]

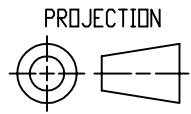

25 & 26 AL, AM, AP 03
(WITH 1 & 2 AL, AM, AP 03)

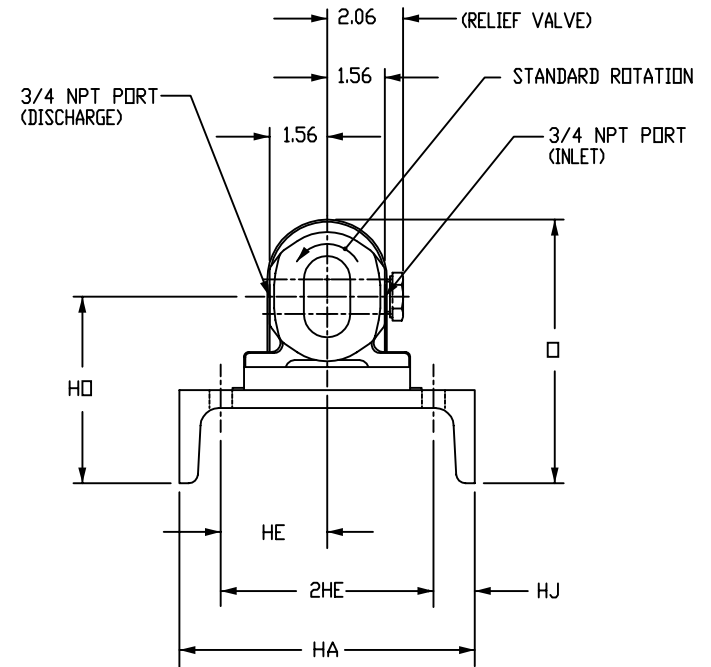
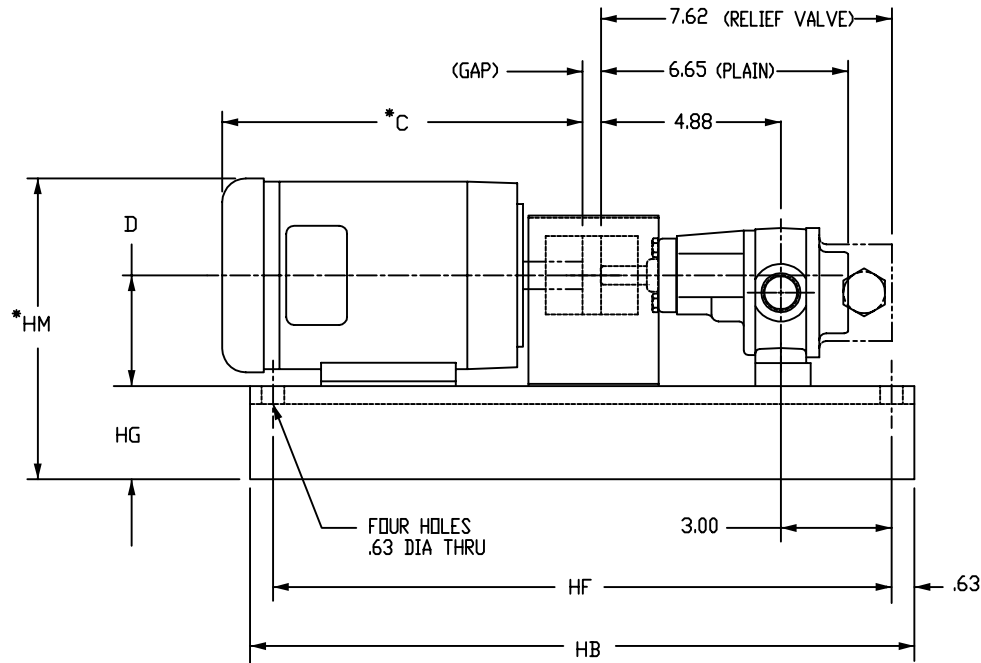

✓	MOTOR FRAME	*MOTOR WEIGHT	BASE/CPLG/HWRE WT	*C	D	*HM	HD	□	(GAP)
	48	22	38	9.31	3.0	8.41	5.06	6.81	.5
	56	34	47	12.31	3.5	9.41	5.56	7.31	.5
	143T	58		12.56					
	145T	65		12.82					
	182T	97	70	16.56	4.5	11.86	7.20	8.95	.75
	184T	110		18.06					

✓	MOTOR FRAME	HA	HB	HE	2HE	HF	HG	HJ
	48	8	18	2.88	5.75	16.75	2.53	1.12
	56	8	24	2.88	5.75	22.75	2.53	1.12
	143T							
	145T							
	182T	12	24	4.75	9.5	22.75	3.17	1.25
	184T							

✓ = UNIT SELECTED

DIMENSIONS IN INCHES
WEIGHTS IN POUNDS

* DIMENSIONS AND MOTOR WEIGHTS WILL VARY BASED ON MOTOR MANUFACTURER AND TYPE. CHART DIMENSIONS AND MOTOR WEIGHTS BASED ON TEFC 3 PHASE MOTORS.

RV = RELIEF VALVE

LOVEJOY COUPLINGS STANDARD

APPROXIMATE MAX PUMP WEIGHT = 8 LBS



ROPER PUMP COMPANY
P.O. BOX 269
3475 OLD MAYSVILLE RD
COMMERCE, GEORGIA 30529 U.S.A.

TELEPHONE: (706) 335-5551
TELEFAX: (706) 335-5505

DATE: _____

PUMP NO.: _____

ROPER NO.: _____

CUSTOMER: _____

CUSTOMER NO.: _____

SERVICE: _____

25 & 26 AL, AM, AP 03
(WITH 17 & 18 AL, AM, AP 03)

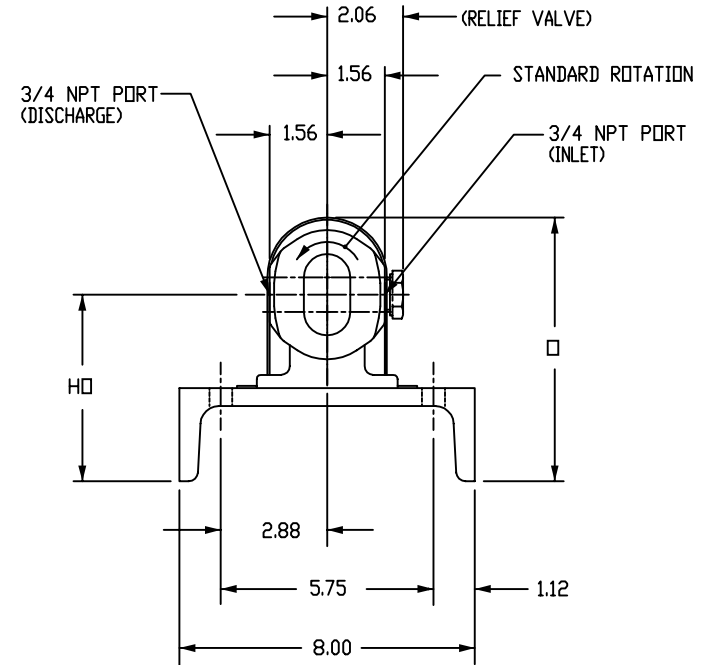
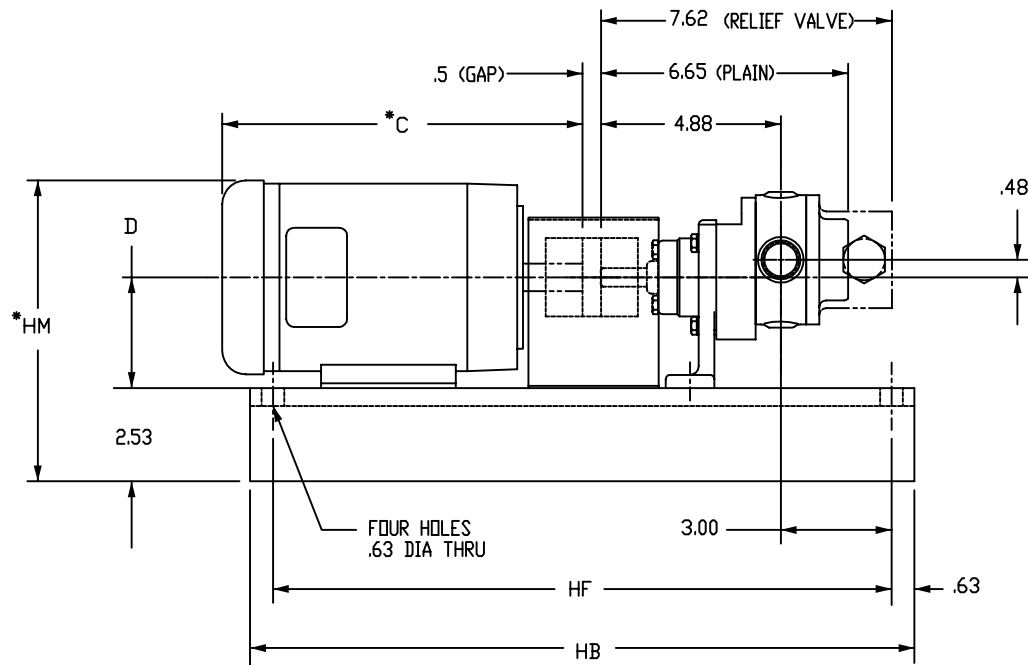

✓ = UNIT SELECTED

DIMENSIONS IN INCHES
WEIGHTS IN POUNDS

* DIMENSIONS AND MOTOR WEIGHTS WILL VARY BASED ON
MOTOR MANUFACTURER AND TYPE. CHART DIMENSIONS
AND MOTOR WEIGHTS BASED ON TEFC 3 PHASE MOTORS.

RV = RELIEF VALVE

LOVEJOY COUPLINGS STANDARD
APPROXIMATE PUMP WEIGHT = 8 LBS

✓	MOTOR FRAME	*MOTOR WEIGHT	BASE/CPLG/ HDWRE WT	*C	D	HB	HF	*HM	HO	□
	48	22	38	9.31	3.0	18	16.75	8.41	5.06	6.81
	56	34	47	12.31	3.5	24	22.75	9.41	5.56	7.31
	143T	58		12.56						
	145T	65		12.82						



ROPER PUMP COMPANY
P.O. BOX 269
3475 OLD MAYSVILLE RD
COMMERCE, GEORGIA 30529 U.S.A.

TELEPHONE: (706) 335-5551
TELEFAX: (706) 335-5505

DATE: _____

PUMP NO.: _____

ROPER NO.: _____

CUSTOMER: _____

CUSTOMER NO.: _____

SERVICE: _____

33 & 34 AL, AM, AP 03

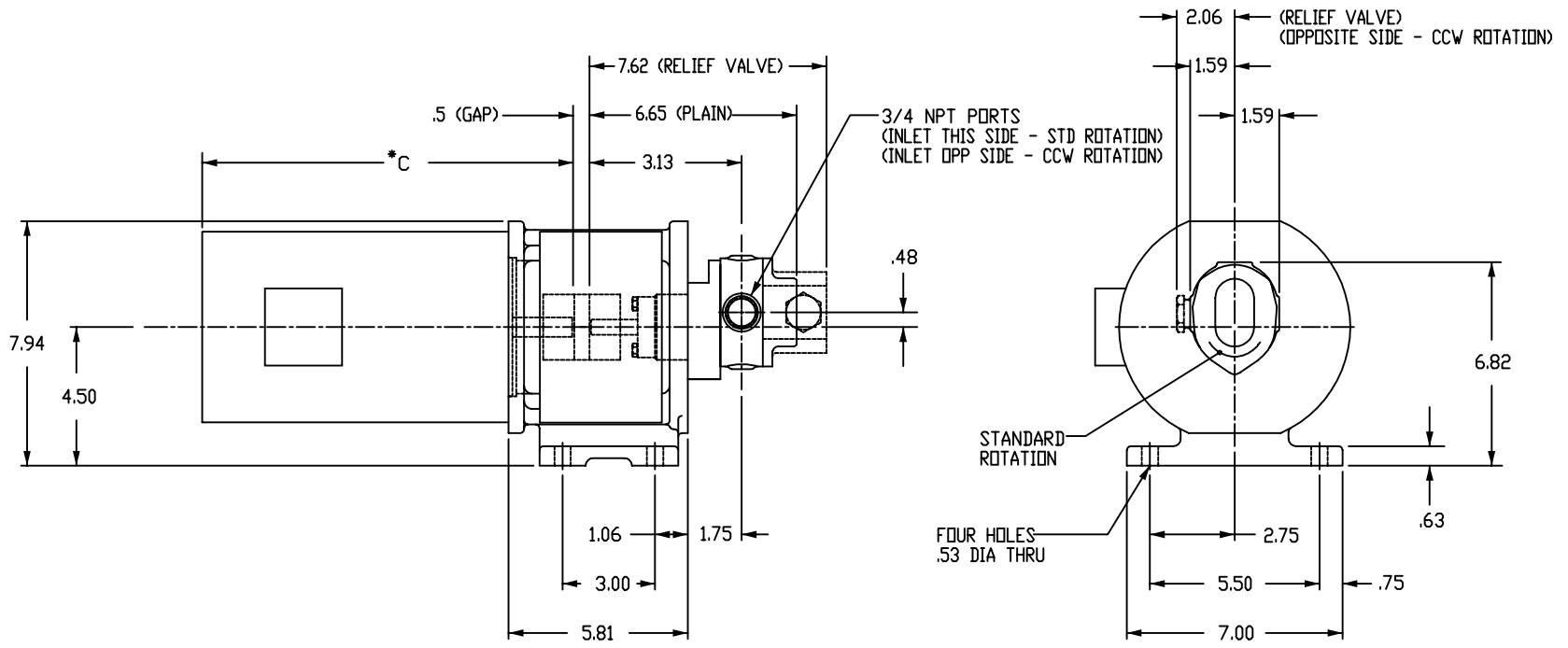

✓ = UNIT SELECTED
 DIMENSIONS IN INCHES
 WEIGHTS IN POUNDS
 * DIMENSIONS AND MOTOR WEIGHTS WILL VARY BASED ON MOTOR MANUFACTURER AND TYPE. CHART DIMENSIONS AND MOTOR WEIGHTS BASED ON TEFC 3 PHASE MOTORS.
 RV = RELIEF VALVE
 LOVEJOY COUPLINGS STANDARD
 APPROX MAX PUMP WEIGHT = 8 LBS

✓	MOTOR FRAME	*MOTOR WEIGHT	BRACKET/CPLG/HDWRE WT	*C
	48CΔ	22	38	9.31
	56C	34	47	12.31
	143TC	58		12.56
	145TC	65		12.82

Δ NEMA FRAME 48C WITH 56C MOUNTING



ROPER PUMP COMPANY
 P.O. BOX 269
 3475 OLD MAYSVILLE RD
 COMMERCE, GEORGIA 30529 U.S.A.

TELEPHONE: (706) 335-5551
 TELEFAX: (706) 335-5505

DATE: _____
 PUMP NO.: _____
 ROPER NO.: _____
 CUSTOMER: _____
 CUSTOMER NO.: _____
 SERVICE: _____

33 & 34 AL, AM, AP 03

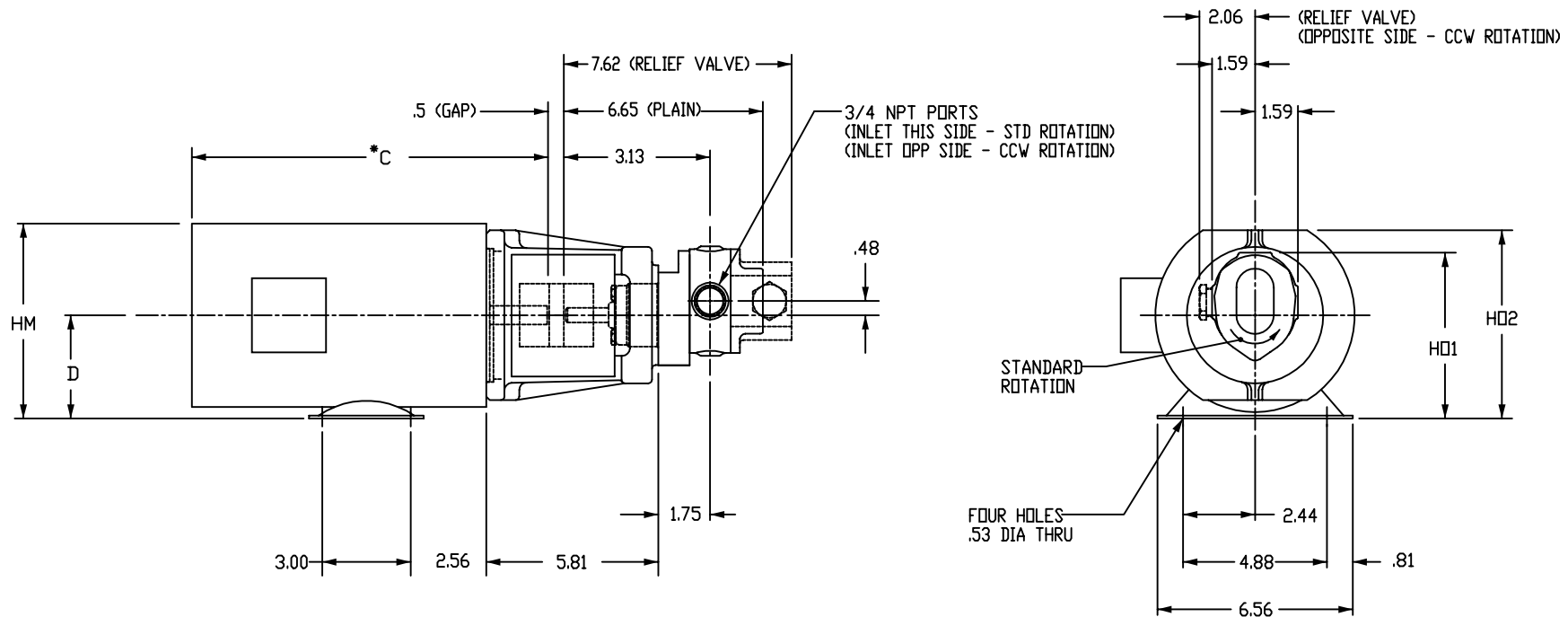

✓ = UNIT SELECTED

DIMENSIONS IN INCHES
WEIGHTS IN POUNDS

* DIMENSIONS AND MOTOR WEIGHTS WILL VARY BASED ON MOTOR MANUFACTURER AND TYPE. CHART DIMENSIONS AND MOTOR WEIGHTS BASED ON TEFC 3 PHASE MOTORS.

RV = RELIEF VALVE

LOVEJOY COUPLINGS STANDARD
APPROX MAX PUMP WEIGHT = 8 LBS

✓ MOTOR FRAME	*MOTOR WEIGHT	BRACKET/CPLG/HWRE WT	*C	D	HM	HO1	HO2
48CΔ	22	38	9.31	3.00	5.88	5.16	5.88
56C	34	47	12.31	3.50	6.94	5.66	6.38
143TC	58		12.56				
145TC	65		12.82				

Δ NEMA FRAME 48C WITH 56C MOUNTING



ROPER PUMP COMPANY
P.O. BOX 269
3475 OLD MAYSVILLE RD
COMMERCE, GEORGIA 30529 U.S.A.

TELEPHONE: (706) 335-5551
TELEFAX: (706) 335-5505

DATE: _____

PUMP NO.: _____

ROPER NO.: _____

CUSTOMER: _____

CUSTOMER NO.: _____

SERVICE: _____

1 & 2 AM, AP 06-16

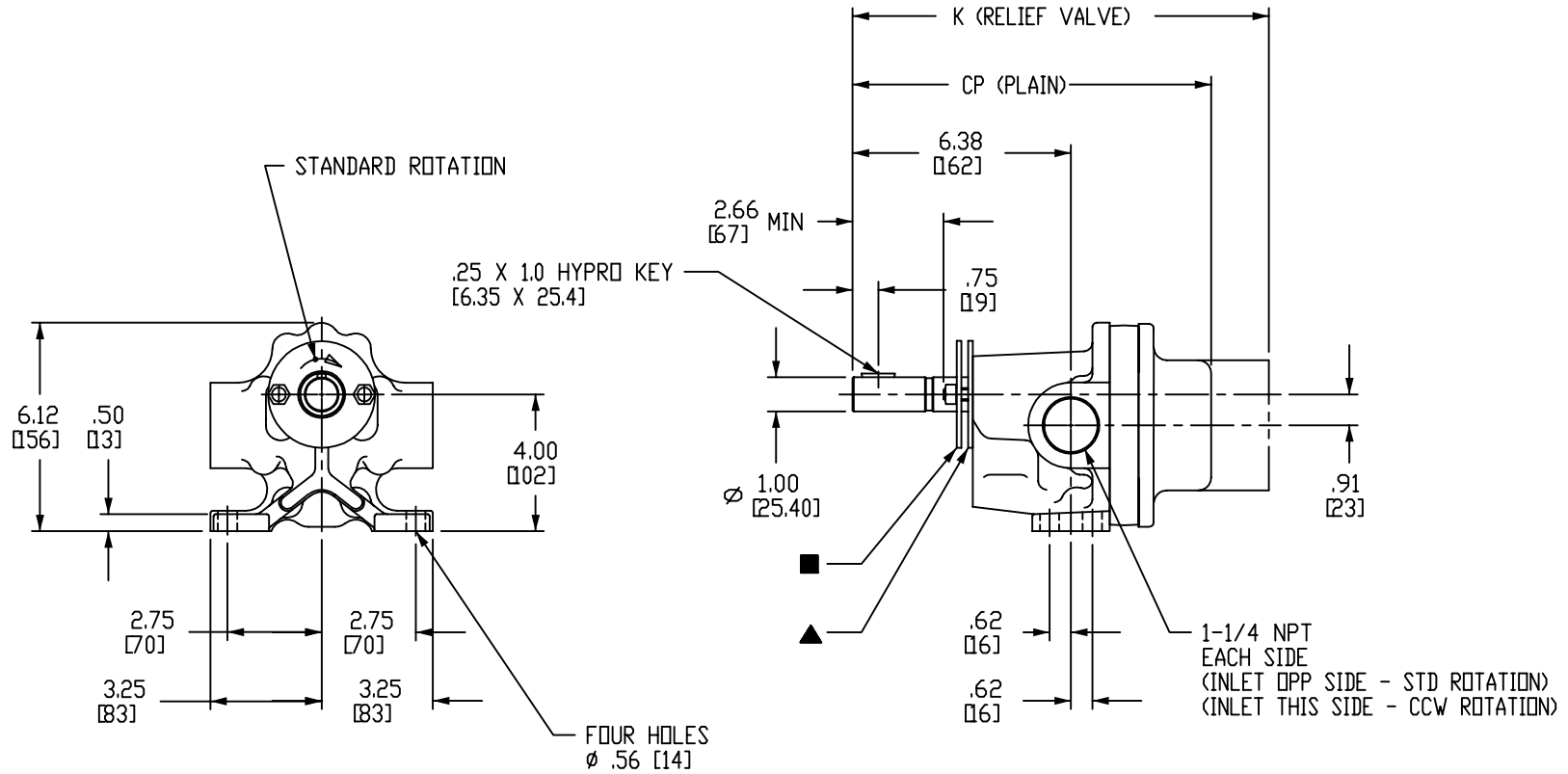

PUMP	CP	K
06	10.47 [266]	12.16 [309]
08	10.75 [273]	12.44 [316]
12	11.31 [287]	13.00 [330]
16	11.88 [302]	13.56 [344]

DO NOT SCALE
DIMS IN INCHES [MM]

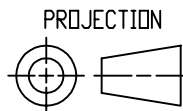

- PACKING PLATE POSITION ON AP PUMP.
- ▲ SEAL RETAINER POSITION ON AL & AM PUMP.

17 & 18 AM, AP 06-16

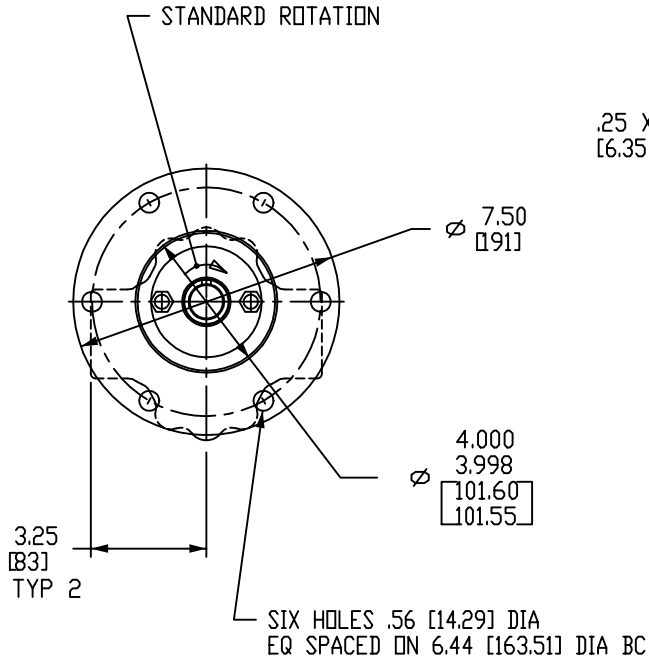

.25 X 1.0 HYPRO KEY
[6.35 X 25.4]

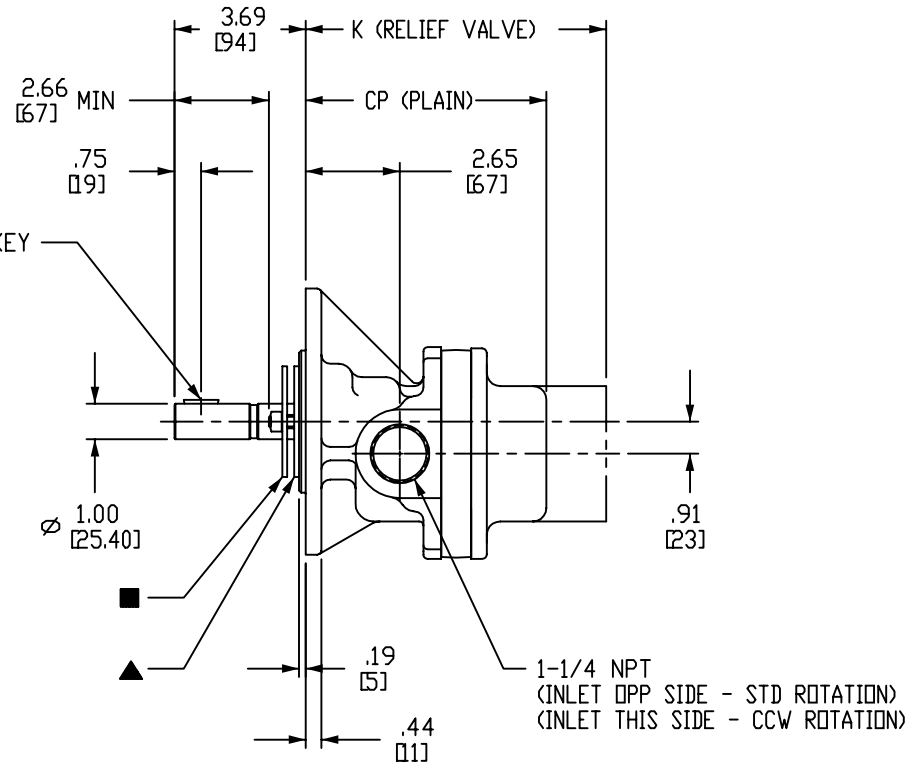

PUMP	CP	K
06	6.78 [172]	8.46 [215]
08	7.06 [179]	8.75 [222]
12	7.62 [194]	9.31 [237]
16	8.19 [208]	9.88 [251]

DO NOT SCALE
DIMS IN INCHES [MM]

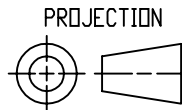

- PACKING PLATE POSITION ON AP PUMP.
- ▲ SEAL RETAINER POSITION ON AL & AM PUMP.

25 & 26 AM, AP 06-16

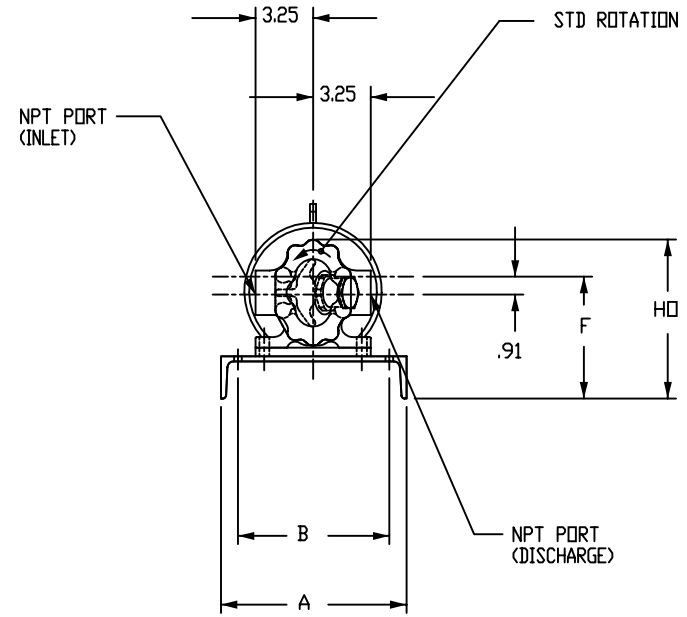
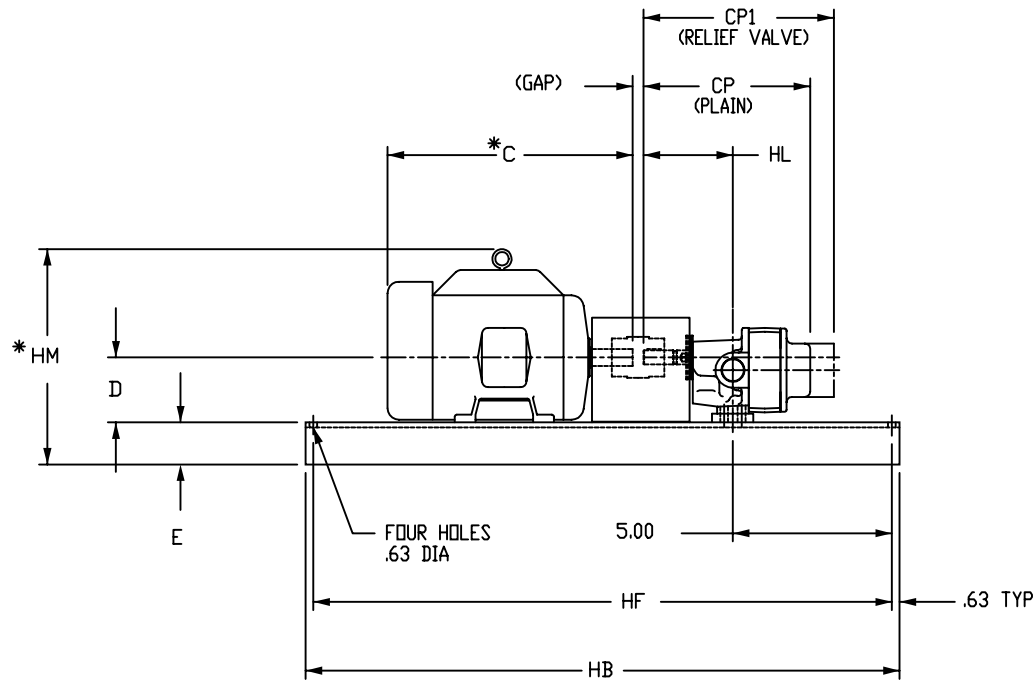

✓	PUMP	PORT SIZE	CP	CP1	HL	APPROXIMATE PUMP WEIGHT	
						PLAIN	W/RV
✓	1 & 2 AL, AM, AP 06	1-1/4" NPT	10.47	12.16	6.38	26	28
✓	1 & 2 AL, AM, AP 08	1-1/4" NPT	10.75	12.44	6.38	26	28
✓	1 & 2 AL, AM, AP 12	1-1/4" NPT	11.31	13.00	6.38	28	30
✓	1 & 2 AL, AM, AP 16	1-1/4" NPT	11.88	13.56	6.38	30	32

✓ = UNIT SELECTED
DIMENSIONS IN INCHES
WEIGHTS IN POUNDS

* DIMENSIONS AND MOTOR WEIGHTS WILL VARY BASED ON MOTOR MANUFACTURER AND TYPE. CHART DIMENSIONS AND MOTOR WEIGHTS BASED ON TEFC 3 PHASE MOTORS.

RV = RELIEF VALVE
LOVEJOY COUPLINGS STANDARD

✓	MOTOR FRAME	*MOTOR WEIGHT	BASE/CPLG/HWRE WT	A	B	*C	D	E	F	HD	*HM	HB	HF	(GAP)	
	56	34	73	12	9.5	12.31	4.0	3.17	7.17	9.29	10.76	24	22.75	.5	
	143T	58				12.56					11.36				
	145T	65				12.82									
	182T	97	96	15	12.25	16.56	4.5	3.38	7.88	10.00	14.63	30	28.75	.75	
	184T	110				18.06									
	213T	162	100	15	12.25	18.56	5.25	3.38	8.63	10.75	16.38	30	28.75	.88	
	215T	189				21.09									
	254T	283				23.19									6.25



ROPER PUMP COMPANY
P.O. BOX 269
3475 OLD MAYSVILLE RD
COMMERCE, GEORGIA 30529 U.S.A.

TELEPHONE: (706) 335-5551
TELEFAX: (706) 335-5505

DATE: _____

PUMP NO.: _____

ROPER NO.: _____

CUSTOMER: _____

CUSTOMER NO.: _____

SERVICE: _____

33 & 34 AM, AP 06-16

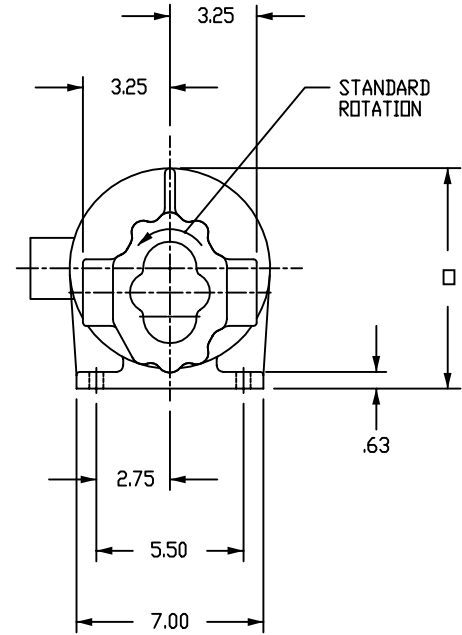
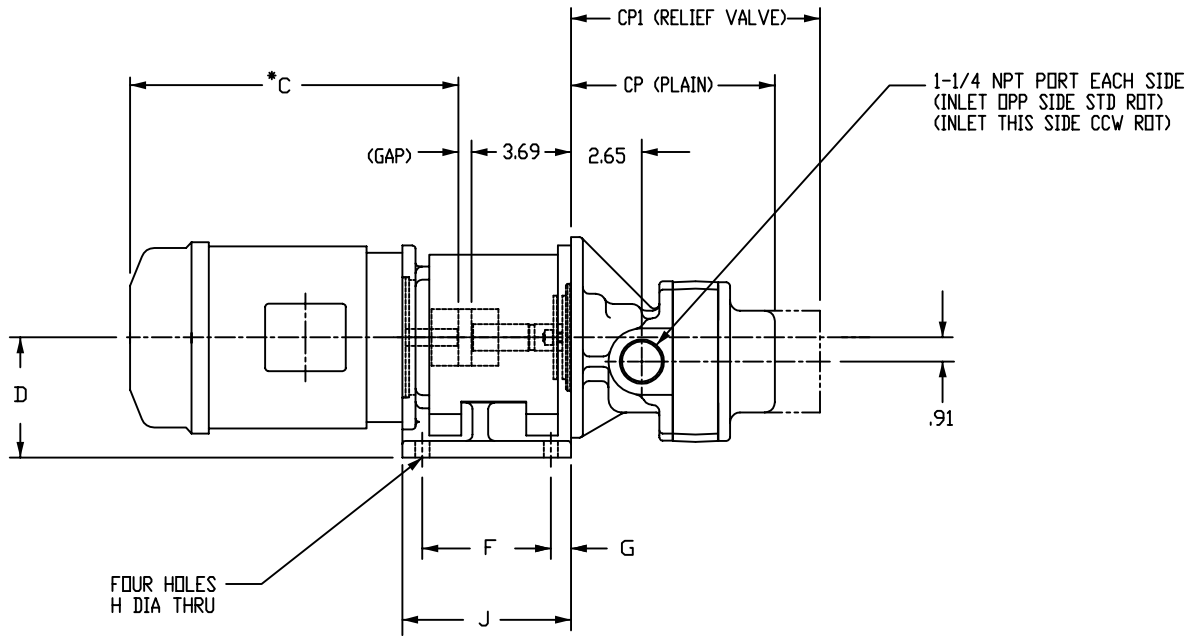

✓ = UNIT SELECTED
 DIMENSIONS IN INCHES
 WEIGHTS IN POUNDS
 * DIMENSIONS AND MOTOR WEIGHTS WILL VARY BASED ON
 MOTOR MANUFACTURER AND TYPE. CHART DIMENSIONS
 AND MOTOR WEIGHTS BASED ON TEFC 3 PHASE MOTORS.
 RV = RELIEF VALVE
 LOVEJOY COUPLINGS STANDARD

✓	PUMP	CP	CP1	PLAIN	W/RV	APPROXIMATE PUMP WEIGHT
	06	6.78	8.46	26	28	
	08	7.06	8.75	26	28	
	12	7.62	9.31	28	30	
	16	8.19	9.88	30	32	

✓	MOTOR FRAME	MOTOR WEIGHT	BRACKET/CPLG/ HDWRE WT	*C	D	F	G	H	J	□	(GAP)
	56C	34	35	12.31	4.50	3.00	1.56	.53	6.31	8.25	.56
	143TC	58		12.56							.50
	145TC	65		12.82							
	182TC	97	45	16.56	6.25	3.50	2.31	.56	7.56	10.75	1.56
	184TC	110		18.06							
	213TC	162	55	18.56							6.25
	215TC	189		21.09							
	254TC	283	65	23.19	6.25	3.50	2.31	.56	7.56	10.75	
	256TC	290									



ROPER PUMP COMPANY
 P.O. BOX 269
 3475 OLD MAYSVILLE RD
 COMMERCE, GEORGIA 30529 U.S.A.

TELEPHONE: (706) 335-5551
 TELEFAX: (706) 335-5505

DATE: _____
 PUMP NO.: _____
 ROPER NO.: _____
 CUSTOMER: _____
 CUSTOMER NO.: _____
 SERVICE: _____

33 & 34 AM, AP 06-16

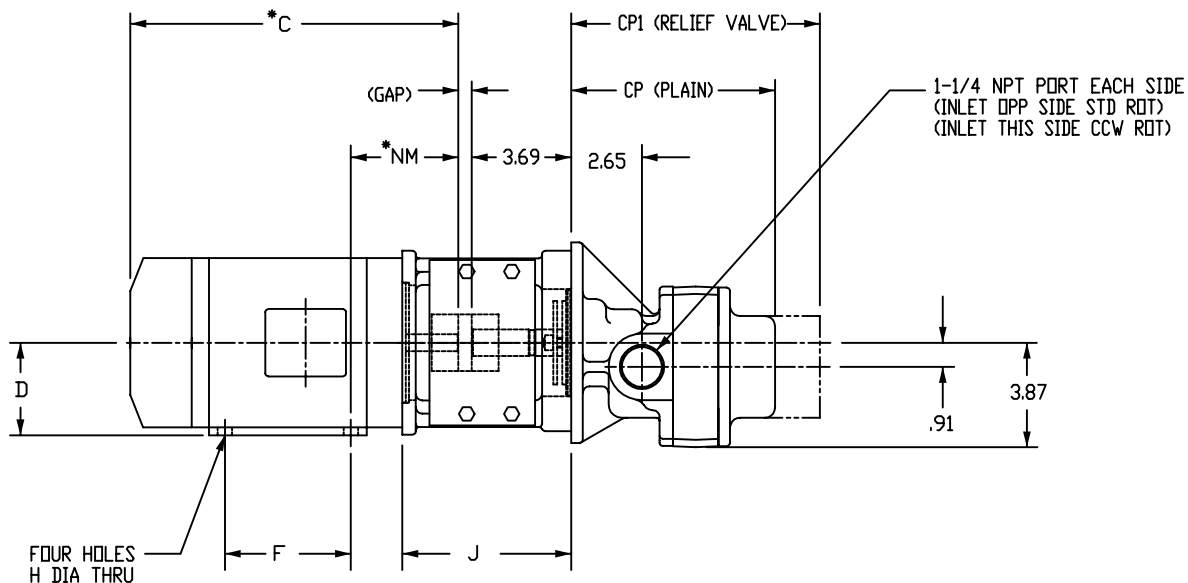

					APPROXIMATE PUMP WEIGHT
✓	PUMP	CP	CP1	PLAIN	W/RV
	06	6.78	8.46	26	28
	08	7.06	8.75	26	28
	12	7.62	9.31	28	30
	16	8.19	9.88	30	32

✓	MOTOR FRAME	*MOTOR WEIGHT	BRACKET/CPLG/HWRE WT	*C	D	E	2E	F	H	J	NM	□	(GAP)
	56C	34		12.31		2.44	4.88	5.00			4.63		.56
	143TC	58	35	12.56	3.50	2.75	5.50	4.00	.34	6.25	4.50	7.00	.50
	145TC	65		12.82				5.00					
	182TC	97	45	16.56	4.50	3.75	7.50	4.50			5.50	8.69	1.50
	184TC	110		18.06				5.50	.41				
	213TC	162	55	18.56	5.25	4.25	8.50	5.50		7.75	6.88	10.25	1.00
	215TC	189		21.09				7.00					
	254TC	283	65	23.19	6.25	5.00	10.00	8.25	.53		8.25	12.88	.38
	256TC	290						10.00					

✓ = UNIT SELECTED

DIMENSIONS IN INCHES
WEIGHTS IN POUNDS

* DIMENSIONS AND MOTOR WEIGHTS WILL VARY BASED ON MOTOR MANUFACTURER AND TYPE. CHART DIMENSIONS AND MOTOR WEIGHTS BASED ON TEFC 3 PHASE MOTORS.

RV = RELIEF VALVE

LOVEJOY COUPLINGS STANDARD



ROPER PUMP COMPANY
P.O. BOX 269
3475 OLD MAYSVILLE RD
COMMERCE, GEORGIA 30529 U.S.A.

TELEPHONE: (706) 335-5551
TELEFAX: (706) 335-5505

DATE: _____

PUMP NO.: _____

ROPER NO.: _____

CUSTOMER: _____

CUSTOMER NO.: _____

SERVICE: _____

1 & 2 AM, AP 21-40

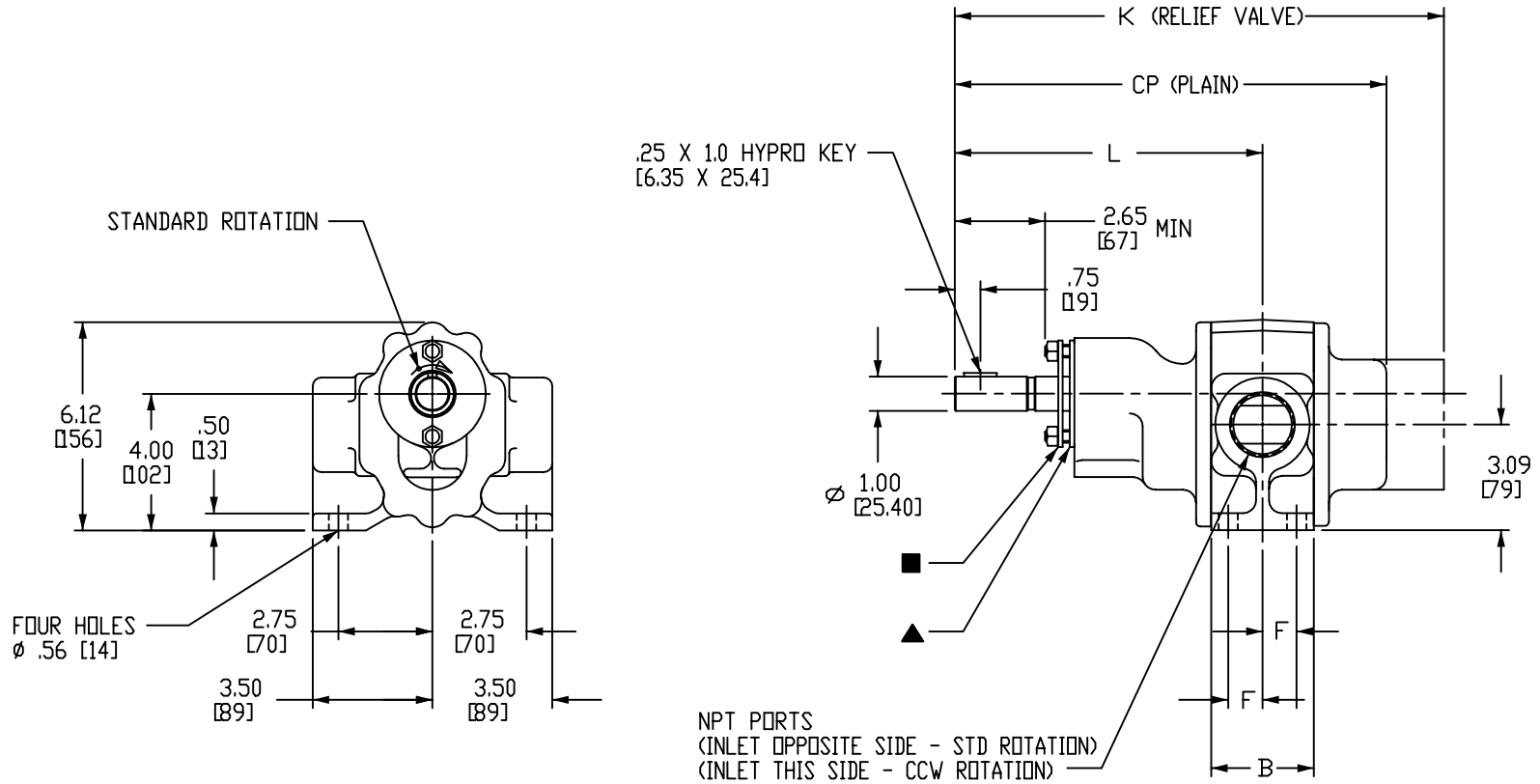

PUMP	B	CP	F	K	L	PORTS
21	3.00 [76]	12.62 [321]	1.00 [25]	14.31 [364]	9.00 [229]	1-1/2"
27	3.75 [95]	13.38 [340]	1.38 [35]	15.06 [383]	9.38 [238]	2"
32	4.50 [114]	14.12 [359]	1.75 [44]	15.81 [402]	9.75 [248]	2"
40	4.50 [114]	14.12 [359]	1.75 [44]	15.81 [402]	9.75 [248]	2"

DO NOT SCALE
DIMS IN INCHES [MM]

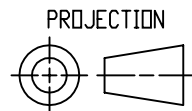

- PACKING PLATE POSITION ON AP PUMP.
- ▲ SEAL RETAINER POSITION ON AM PUMP.

17 & 18 AM, AP 21-40

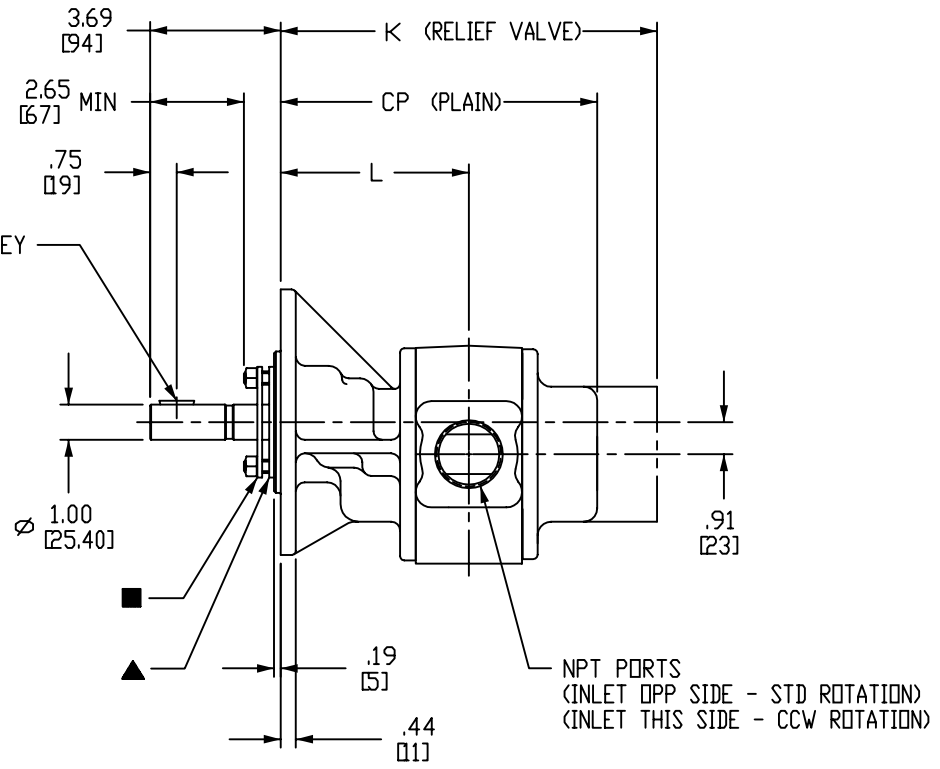
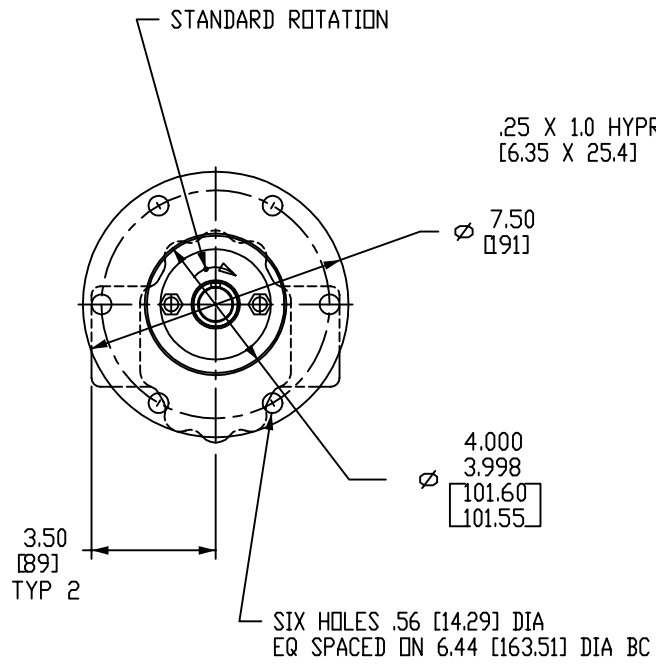

PUMP	CP	K	L	PORTS
21	8.94 [227]	10.62 [270]	5.31 [135]	1-1/2"
27	9.69 [246]	11.38 [289]	5.69 [145]	2"
32	10.44 [265]	12.12 [308]	6.06 [154]	2"
40	10.44 [265]	12.12 [308]	6.06 [154]	2"

DO NOT SCALE
DIMS IN INCHES [MM]

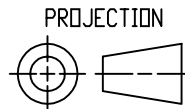

- PACKING PLATE POSITION ON AP PUMP.
- ▲ SEAL RETAINER POSITION ON AM PUMP.

25 & 26 AM, AP 21-40

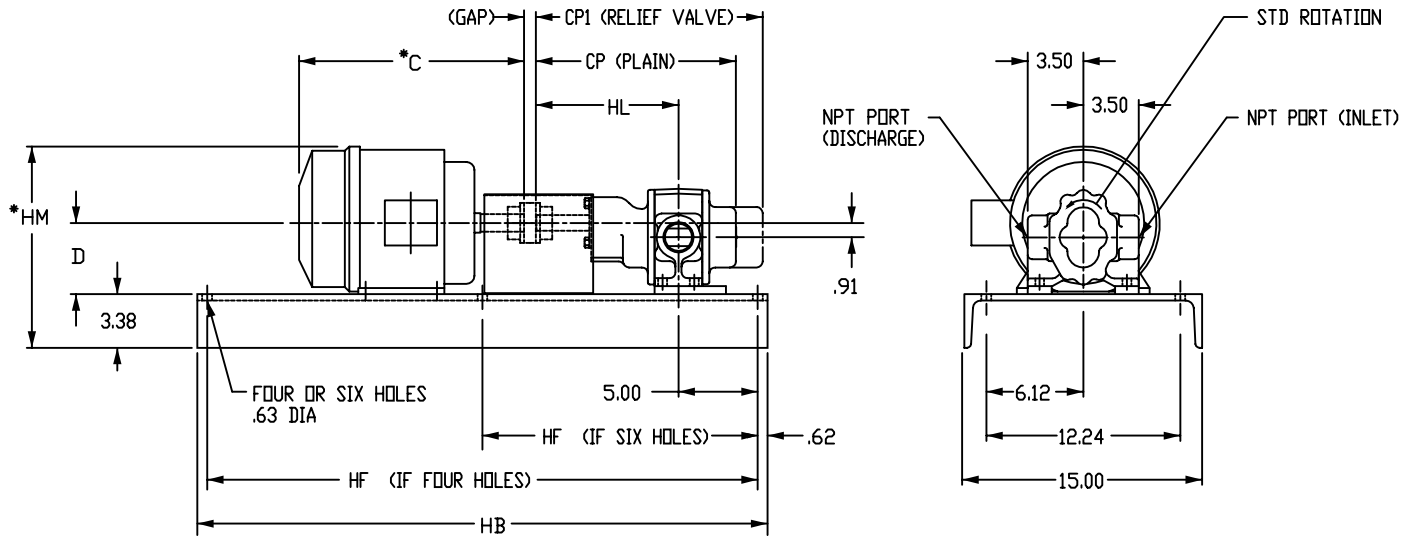

ALL BASES HAVE QTY FOUR HOLES EXCEPT:
QTY SIX HOLES FOR PUMP SIZE 27, 32, AND 40 WITH FRAME
FRAME 254T, 256T, OR 284T MOTORS

✓ PUMP	PORT SIZE	CP	CP1	HL	APPROXIMATE PUMP WEIGHT	
					PLAIN	W/RV
1 & 2 AM, AP 21	1-1/2" NPT	12.62	14.31	9.00	45	47
1 & 2 AM, AP 27	2" NPT	13.38	15.06	9.38	48	50
1 & 2 AM, AP 32	2" NPT	14.12	15.81	9.75	50	52
1 & 2 AM, AP 40	2" NPT	14.12	15.81	9.75	52	54

✓ = UNIT SELECTED
DIMENSIONS IN INCHES
WEIGHTS IN POUNDS

* DIMENSIONS AND MOTOR WEIGHTS WILL VARY BASED ON
MOTOR MANUFACTURER AND TYPE. CHART DIMENSIONS
AND MOTOR WEIGHTS BASED ON TEFC 3 PHASE MOTORS.

RV = RELIEF VALVE
LOVEJOY COUPLINGS STANDARD

✓ MOTOR FRAME	*MOTOR WEIGHT	BASE/CPLG/ HDWRE WT	*C	D	*HM	HB			HF			(GAP)
						21	27	32-40	21	27	32-40	
145T	65	100	12.82	4.00	11.36	30	30	30	28.75	28.75	28.75	.50
182T	97	120	16.56	4.50	14.63	36	36	36	34.75	34.75	34.75	.75
184T	110		18.06									
213T	162	120	18.56	5.25	16.38	36	36	36	34.75	34.75	34.75	.88
215T	189		21.09									
254T	283	145	23.19	6.25	17.57	36	40	40	34.75	19.38	19.38	1.0
256T	290					N/A			N/A			
284T	350					N/A			N/A			



ROPER PUMP COMPANY
P.O. BOX 269
3475 OLD MAYSVILLE RD
COMMERCE, GEORGIA 30529 U.S.A.

TELEPHONE: (706) 335-5551
TELEFAX: (706) 335-5505

DATE: _____

PUMP NO.: _____

ROPER NO.: _____

CUSTOMER: _____

CUSTOMER NO.: _____

SERVICE: _____

33 & 34 AL, AM, AP 21-40

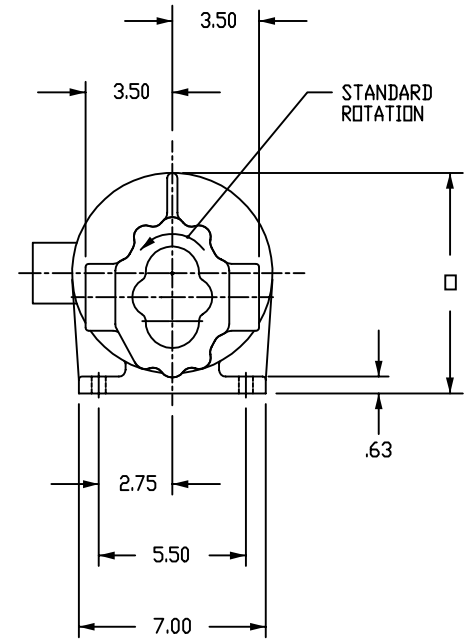
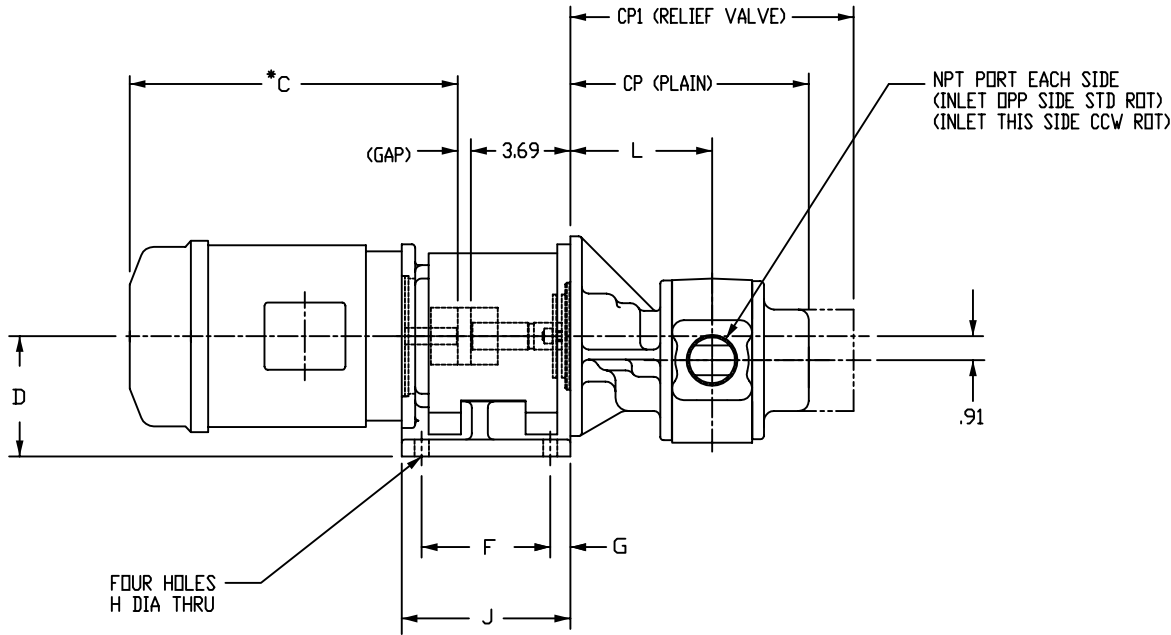

✓	PUMP	CP	CP1	L	PORTS	APPROXIMATE PUMP WEIGHT	
						PLAIN	W/RV
	21	8.94	10.62	5.31	1-1/2"	45	47
	27	9.69	11.38	5.69	2"	48	50
	32	10.44	12.12	6.06	2"	50	52
	40	10.44	12.12	6.06	2"	52	54

✓	MOTOR FRAME	*MOTOR WEIGHT	BRACKET/CPLG/HWRE WT	*C	D	F	G	H	J	□	(GAP)	
	56C	34	35	12.31	4.50	3.00	1.56	.53	6.31	8.25	.56	
	143TC	58		12.56							.50	
	145TC	65		12.82								
	182TC	97	45	16.56	6.25	3.50	2.31	.56	7.56	10.75	1.56	
	184TC	110		18.06								
	213TC	162	55	18.56								1.06
	215TC	189		21.09								
	254TC	283										
	256TC	290	65	23.19								.44

✓ = UNIT SELECTED

DIMENSIONS IN INCHES
WEIGHTS IN POUNDS

* DIMENSIONS AND MOTOR WEIGHTS WILL VARY BASED ON MOTOR MANUFACTURER AND TYPE. CHART DIMENSIONS AND MOTOR WEIGHTS BASED ON TEFC 3 PHASE MOTORS.

RV = RELIEF VALVE

LOVEJOY COUPLINGS STANDARD



ROPER PUMP COMPANY
P.O. BOX 269
3475 OLD MAYSVILLE RD
COMMERCE, GEORGIA 30529 U.S.A.

TELEPHONE: (706) 335-5551
TELEFAX: (706) 335-5505

DATE: _____

PUMP NO.: _____

ROPER NO.: _____

CUSTOMER: _____

CUSTOMER NO.: _____

SERVICE: _____

33 & 34 AL, AM, AP 21-40

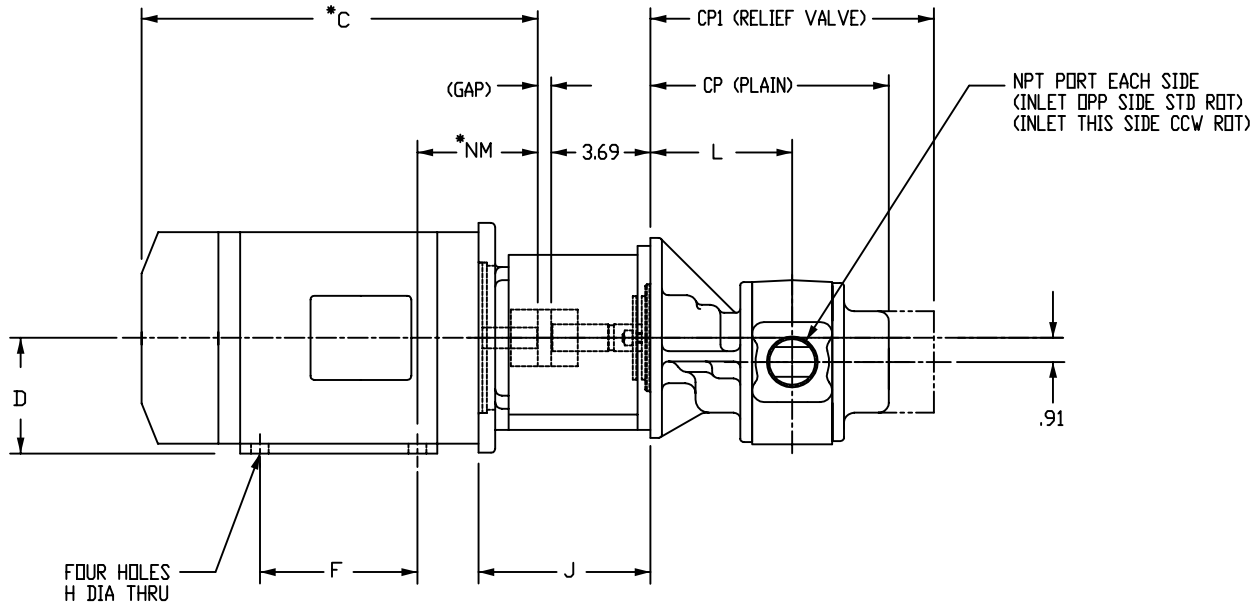

✓	PUMP	CP	CP1	L	PORTS	APPROXIMATE PUMP WEIGHT	
						PLAIN	W/RV
	21	8.94	10.62	5.31	1-1/2"	45	47
	27	9.69	11.38	5.69	2"	48	50
	32	10.44	12.12	6.06	2"	50	52
	40	10.44	12.12	6.06	2"	52	54

✓	MOTOR FRAME	MOTOR WEIGHT	BRACKET/CPLG/HWRE WT	*C	D	E	2E	F	H	J	NM	□	(GAP)
	56C	34	35	12.31	3.50	2.44	4.88	5.00	.34	6.25	4.63	7.00	.56
	143TC	58		12.56		2.75	5.50	4.00			.50		
	145TC	65		12.82		5.00	.50	.50					
	182TC	97	45	16.56	4.50	3.75	7.50	4.50	.41	7.75	5.50	8.69	1.50
	184TC	110		18.06									
	213TC	162	55	18.56	5.25	4.25	8.50	5.50	.41	7.75	6.88	10.25	1.00
	215TC	189		21.09									
	254TC	283	65	23.19	6.25	5.00	10.00	8.25	.53	7.75	8.25	12.88	.38
	256TC	290											

✓ = UNIT SELECTED

DIMENSIONS IN INCHES
WEIGHTS IN POUNDS

* DIMENSIONS AND MOTOR WEIGHTS WILL VARY BASED ON MOTOR MANUFACTURER AND TYPE. CHART DIMENSIONS AND MOTOR WEIGHTS BASED ON TEFC 3 PHASE MOTORS.

RV = RELIEF VALVE

LOVEJOY COUPLINGS STANDARD



ROPER PUMP COMPANY
P.O. BOX 269
3475 OLD MAYSVILLE RD
COMMERCE, GEORGIA 30529 U.S.A.

TELEPHONE: (706) 335-5551
TELEFAX: (706) 335-5505

DATE: _____

PUMP NO.: _____

ROPER NO.: _____

CUSTOMER: _____

CUSTOMER NO.: _____

SERVICE: _____