

# Roper Liquid Feed Molasses Pump

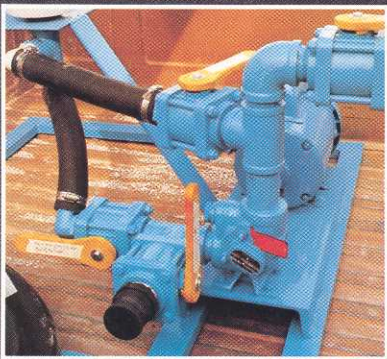

Roper's 2835 rotary pump is built for pumping highly viscous, molasses-based liquid feed supplements. The external helical gear design, combined with extra large ports, allows the 2835 pump to handle even winter-thickened feed supplements with ease. Highly viscous feed can be pumped at speeds of up to 1,800 RPM.

Roper's helical gears, the only moving parts in the pump, assure quiet, smooth operation. Bearings in the Roper 2835 pump are lubricated by the liquid being pumped. Each pump is manufactured to close

tolerances, then individually tested to assure dependable performance.

The Roper 2835 pump allows complete installation flexibility by eliminating the need for risers in direct-coupled applications. When assembled in the high drive configuration, the pump's drive shaft aligns with a NEMA frame 56, 143T electrical motor shaft. When assembled for low drive, the pump's drive shaft aligns with a NEMA frame 48 electrical motor.

Contact Roper Pump Company or your local Roper distributor for more information.

## Advantages

- Angled gear arrangement pumps viscous feed supplements easily.
- Enlarged ports facilitate pumping.
- Capacities up to 12 GPM; pressures to 75 psi; displacement 0.006 GPR. Larger capacity pumps for up to 1,000 GPM are available.
- Low horsepower requirements allow use of low-cost drivers.
- Directly couples to standard electrical motor.
- Operates at standard motor speeds for viscosities up to 100,000 SSU.
- Built-in relief valve helps to protect pump from excessive discharge pressure.
- May be driven by a gasoline engine.



# Dimensions

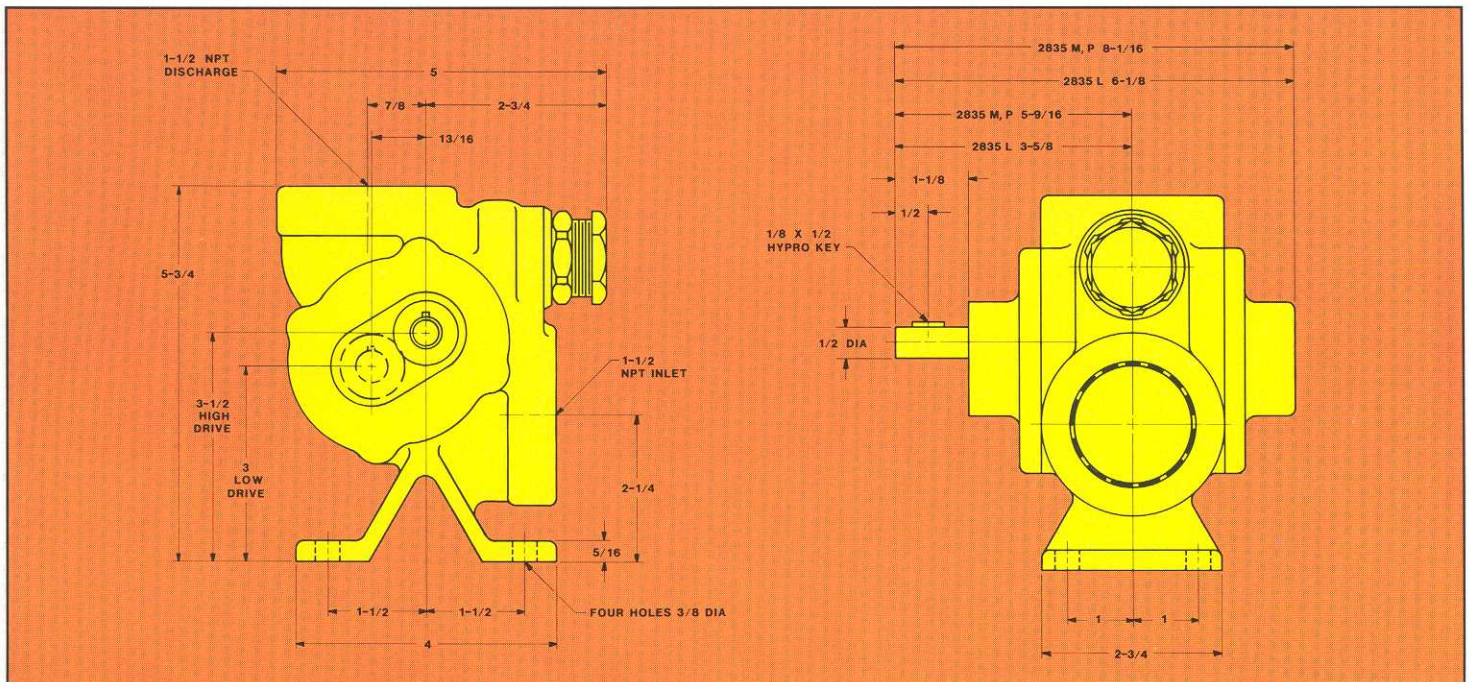

## Baseplate Units

### BASE MOUNTED UNITS

These pumps are available ready to install or as completely assembled pump and driver packages, custom designed and built to individual specifications.

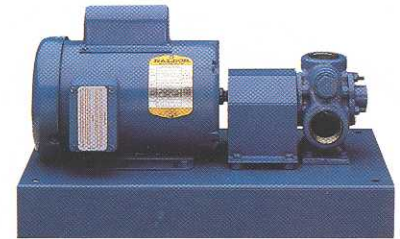

## Performance Chart

PSI		1800 RPM				1200 RPM			
		SSU	100	1000	10,000	100,000	100	1000	10,000
25	GPM	11	11.4	11.5	11.5	7.2	7.5	7.6	7.6
	HP	.28	.40	.63	1.18	.15	.22	.32	.57
50	GPM	10.5	11.3	11.4	11.5	6.6	7.4	7.5	7.6
	HP	.44	.56	.79	1.34	.26	.33	.43	.68
75	GPM	10	11.2	11.3	11.4	6.1	7.3	7.4	7.5
	HP	.60	.72	.95	1.5	.39	.46	.56	.81

Additional sizes available

## Materials Chart

	HOUSING	GEARS	BEARINGS	SHAFTS
STANDARD	Cast Iron	Hardened Steel	Iron	Hardened Steel



Roper Pump Company  
 Commerce, Georgia 30529  
 Dependable pumps since 1857.  
 WATS 1-800-543-1709  
 In GA. (404) 335-5551  
 FAX (404) 335-5505