

# GALLEY FLOW SYSTEM

Model #190012 (12V) #190024 (24V) #190032 (32V)

## OPERATION, MAINTENANCE AND INSTALLATION INSTRUCTIONS

**THE FOLLOWING ARE CAUTIONARY STATEMENTS THAT MUST BE READ AND FOLLOWED DURING BOTH INSTALLATION AND OPERATION.**

**WARNING:** *Raritan Engineering Company, Inc. recommends that a qualified person or electrician install this product. Equipment damage, injury to personnel or death could result from improper installation. Raritan Engineering Company, Inc. accepts no responsibility or liability for damage to equipment, injury or death to personnel that may result from improper installation or operation of this product.*



**WARNING: HAZARD OF SHOCK OR FIRE**



Always use recommended fuse, circuit breaker and wire size.

Motors used with this product are "Ignition Protected". They are not however, explosion-proof as defined in 46CFR 110.15-65(e), Subchapter J-Electrical Engineering.

**WARNING: HAZARD OF FLOODING** - Always shut off pressurized dockside valve and turn off power before leaving the boat unattended.

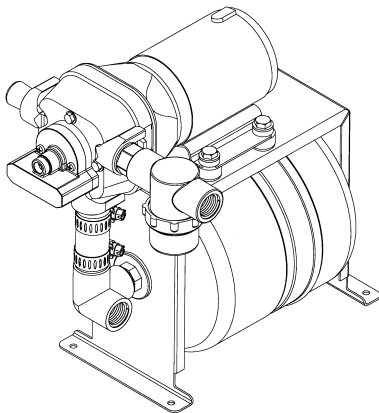

**Galley Flow System**

**#190012 (12V)**

**#190024 (24V)**

**#190032 (32V)**

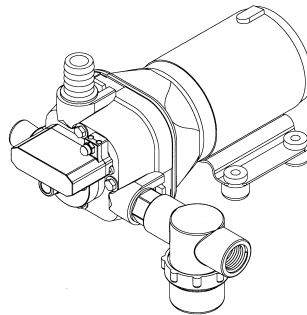

**Galley Flow Pump with Motor,  
In-Line Strainer and**

**Pressure Switch**

**#191012 (12V)**

**#191024 (24V)**

**#191032 (32V)**

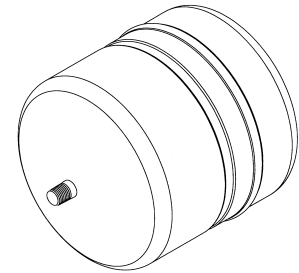

**Pressure Tank**

**#190101**

- The Galley Flow System automatically provides a dependable source of pressurized, evenly flowing freshwater for on-board showers and sinks.
- The Galley Flow System combines pump and accumulator tank in a compact package that is easily mounted.
- Can be run dry without damaging the pump.
- Ignition protected.



**1-800-352-5630**

**www.raritaneng.com**

## When boarding the boat:

- ✓ Make sure freshwater tank is full
- ✓ Open intake valve
- ✓ Restore power to unit

NOTE: First time operation refer to “System Start Up” section on page 3.

## When leaving the boat for an extended time:

- ✓ Shut off intake valve
- ✓ Shut off power to unit

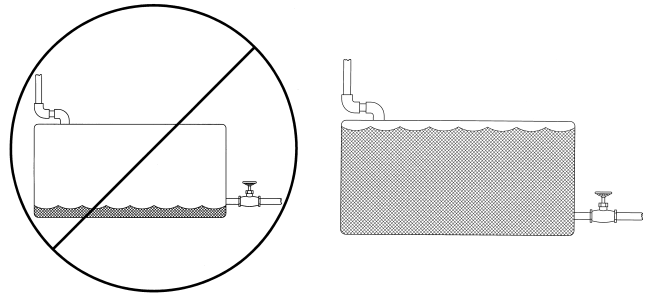

## Recommend Visual Inspection

- ✓ Hose clamps
- ✓ Condition of hoses
- ✓ Condition of wires and connections
- ✓ Electrical connections for corrosion
- ✓ In-Line Strainer

## Cleaning In-Line Strainer

1. Turn off power.
2. Shut off intake water valve.
3. Unscrew bowl.
4. Remove filter.
5. Clean bowl and filter with a clean dry cloth.
6. Clean gasket and gasket contact surfaces thoroughly with a clean dry cloth.
7. Replace gasket, filter and bowl.
8. Open intake water valve.
9. Turn on power.
10. Check for leaks.

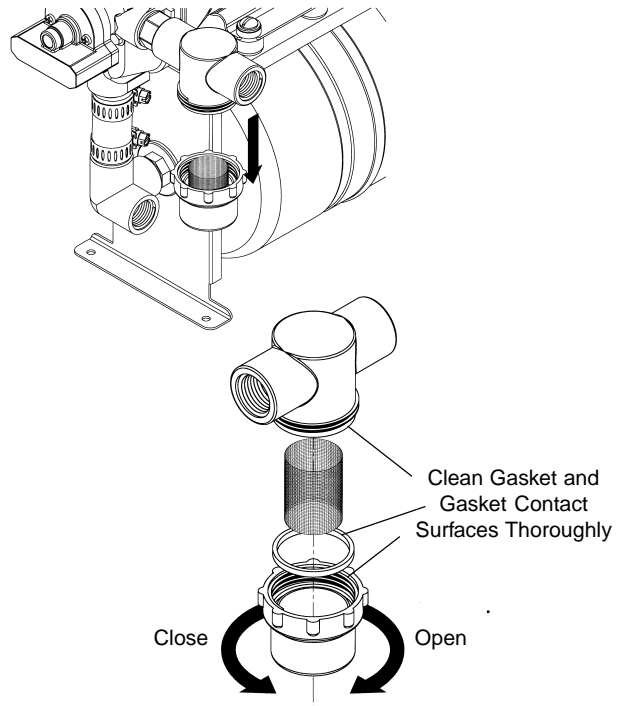

**CAUTION:** Improper winterizing may cause damage. Use one of the two winterizing methods outlined below.

### Winterizing with Antifreeze

**WARNING:** Use only nontoxic antifreeze suitable for potable water.

#### IMPORTANT

- **Dispose of all antifreeze in accordance with local and federal regulations.**
  - **Winterize water tanks, plumbing, water heaters, etc. independently following manufacturer's instructions.**
1. Turn off power.
  2. Shut off intake valve.
  3. Open faucet to relieve pressure.
  4. Disconnect water intake and discharge hoses at pump and replace it with short pieces of same size hose.
  5. Submerge free end of hoses in a bucket containing nontoxic antifreeze.
  6. Turn on power and run until antifreeze is discharged.
  7. Turn off power.
  8. Reconnect intake and discharge hoses.

#### Winterizing without Anti-freeze

1. Turn off power.
2. Shut off intake valve.
3. Disconnect pump, tank intake and discharge hoses.
4. Clear water lines.
5. Turn on power.
6. Run pump briefly (three to five seconds).
7. Turn off power.
8. Reconnect intake and discharge hoses.

#### SYSTEM START-UP

1. Fill freshwater tank, open intake valve and faucets.
2. Turn on power.
3. After Antifreeze has been cleared from the lines, water heater, and water is flowing freely, turn off faucets. The system is now ready to operate automatically!
4. Check systems for leaks.

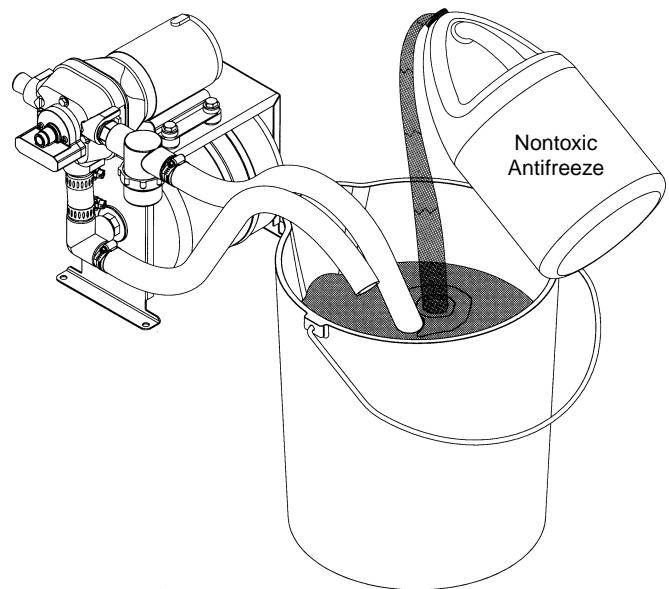

# SPECIFICATIONS

## Parts Included

- Pressure Switch
- In-line Strainer
- Motor
- 1/2" Male NPT Adapters (2)
- 3/4" (19mm) Hose Adapters (2)
- Mounting Frame (not included with #1910\*)
- Pressure Tank (not included with #1910\*)
- Inlet Pump 3/4" Hose Barb Fitting

## Additional Parts Required

- Four (1/4") stainless steel noncorrosive mounting fasteners
- Wire
- Terminals
- Fuse/circuit breaker
- Check valve
- Shutoff valve
- Shut off switch (optional)
- Hose (All hosing/tubing should be FDA approved and rated a minimum of 50 PSI [345kPa] and non collapsible)

## Plumbing

Maximum suction of intake pump	6 ft. (1.8 M)
Factory Set Pressure Range	20 - 40 PSI (138 - 276 kPa)
Accumulator Precharge	18 PSI (124kPa)

## NOTES: for Wiring

1.	Distances are from source to unit and back to source.
2.	If wire runs exceed 50 feet (15.2m) refer to ABYC Standards
3.	Recommended conductor wire minimum AWG (mm <sup>2</sup> ) for 3% voltage drop and fuse/circuit breaker size.
4.	Recommended conductor sizes are based on 105°C rated insulation. Refer to ABYC Standards for other insulation ratings.

## Galley Flow - Recommended Wire and Fuse/Circuit Breaker Size

Units Voltage	Circuit Breaker/fuse size (amps)	Amp. draw @ nominal voltage	10 feet	15 feet	20 feet	30 feet	40 feet	50 feet
12 VDC	15	10	14 AWG	12 AWG	10 AWG	10 AWG	8 AWG	6 AWG
24 VDC	15	7	16 AWG	16 AWG	14 AWG	12 AWG	10 AWG	10 AWG
32 VDC	10	5	16 AWG	16 AWG	16 AWG	16 AWG	16 AWG	14 AWG

## SPECIFICATIONS

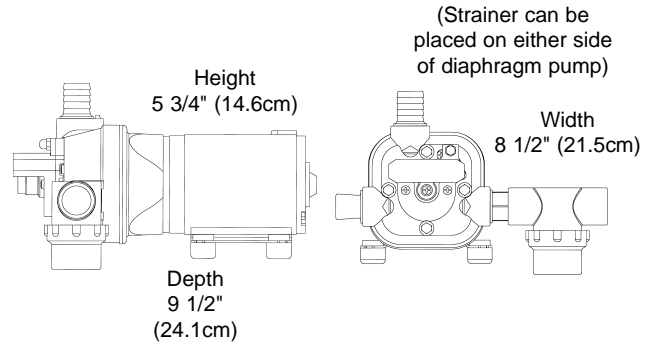
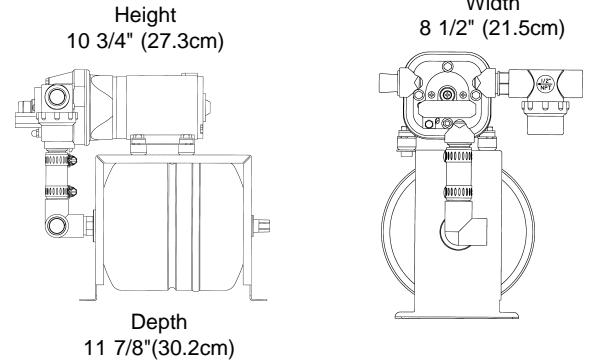

## CONVERSIONS

### Wire - AWG to mm<sup>2</sup>

AWG	16	14	12	10	8	6	4	2
mm <sup>2</sup>	1.5	2.5	4.0	6.0	10.0	16.0	25.0	35.0

### Feet to Meters

Feet	10	15	20	25	30	40	50
Meter	3.1	4.6	6.1	7.6	9.2	12.2	15.2

## Tools Required

- Wrench or screw driver (depending on mounting fastener)
- Bit for drilling mounting surface (depending on fastener used)
- Wire cutters
- Wire terminal crimpers
- Hose cutters
- Tape measure

## MOUNTING

**Galley Flow System may be mounted vertical or horizontal on a flat and solid surface.**

**CAUTION: Do not install Galley Flow System in an area where the temperature may exceed 120° F (49° C).**

### Galley Flow System

1. The Galley Flow System should be as close as possible to the freshwater supply tank, with lift not to exceed six feet (1.8M).
2. Mark the pattern of mounting holes before drilling.
3. Mount with noncorrosive fasteners.

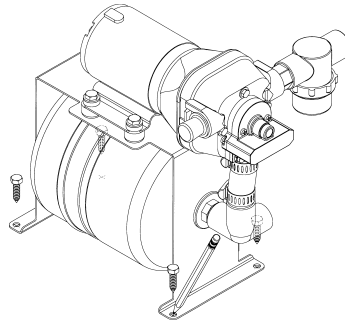
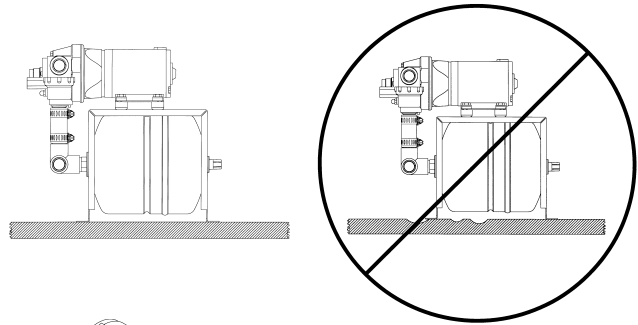

### Galley Flow Pump and Motor

1. The Galley Flow Pump and Motor should be as close as possible to the freshwater supply tank, with lift not to exceed six feet (1.8M).
2. Mark the pattern of mounting holes before drilling.
3. Mount with noncorrosive fasteners.
4. Secure or fasten pressure tank remotely mounted with strapping supplied.

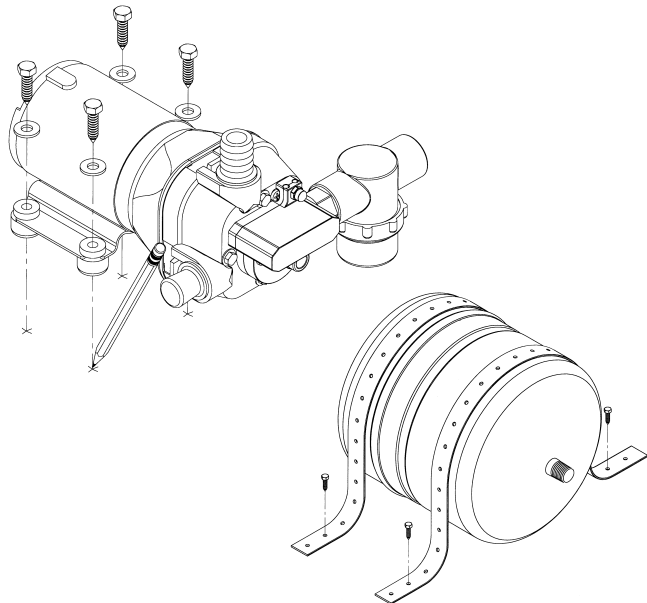

## PLUMBING

### IMPORTANT

- Fittings and 90° bends should be kept to a minimum.
- Secure all hoses properly.
- Use only FDA approved hose that is rated 50 PSI (345kPa) minimum.

1. Remove vinyl caps from inlet and outlet ports.
2. Install in-line strainer (#190601) with fitting (#190405) into inlet port of pump and lock fitting clip.

NOTE: Inlet strainer can be installed on either side of pump. Plug must be installed in unused inlet port.

3. Connect freshwater supply line to intake and faucet supply to pressure tank discharge line.

Note: A check valve must be installed between Galley Flow System and entry of dockside water supply.

We recommend installing a shutoff valve at entry of dockside water supply and between freshwater tank and Galley Flow System.

The freshwater tank MUST be filled through the deck fitting, NOT the water pressure system.

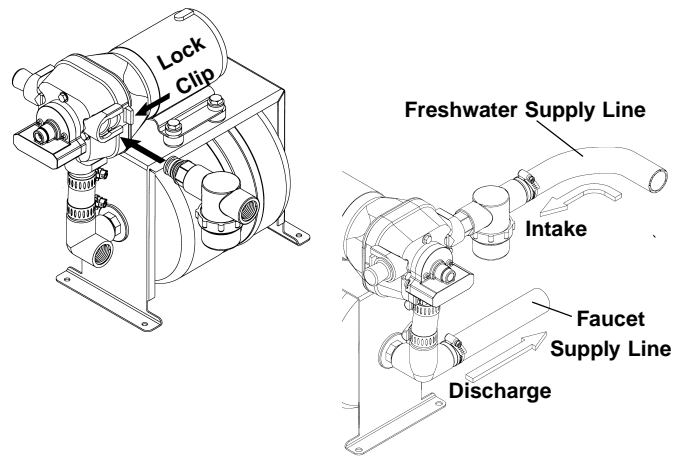

Typical Hook-up of Galley Flow System

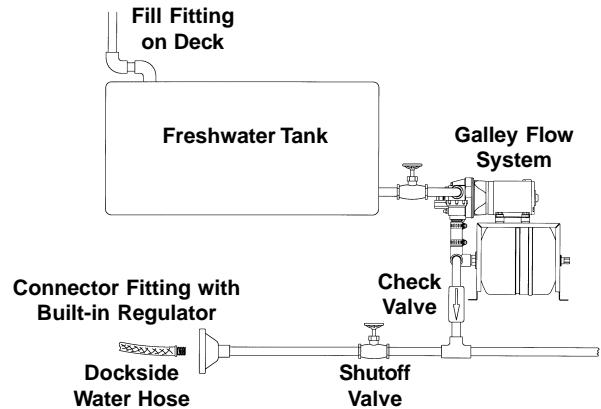

Typical Hook-up of Galley Flow Pump and Motor

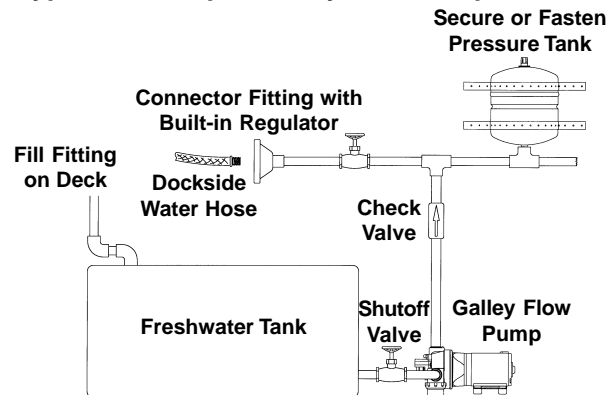

Typical Hook-up of Freshwater (potable) System

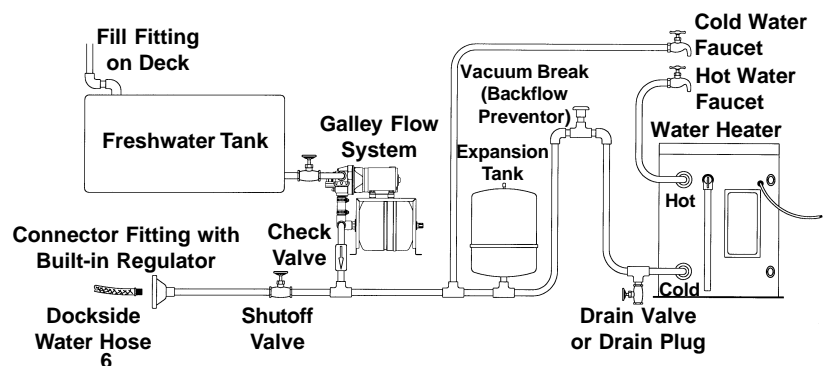

## OPTIONAL INSTALLATION:

The in-line strainer (#190601) can be installed separate from pump. A hose barb fitting (#162410) is included to install in pump.

1. Unscrew fitting (#190405) from in-line strainer (#190601).

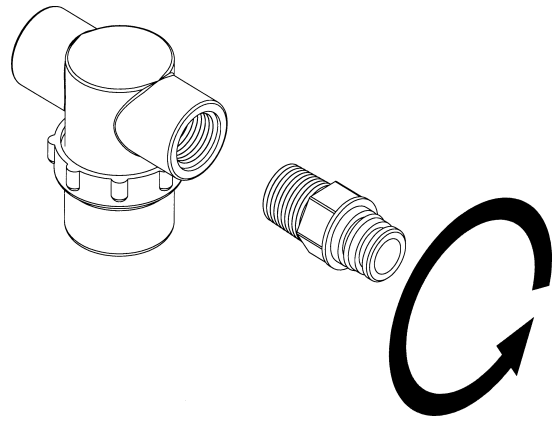

2. Install hose barb fitting (#162410) into pump inlet port and lock fitting clip.

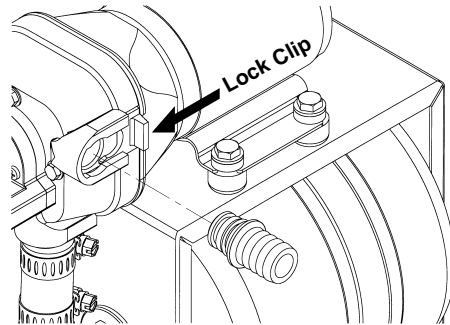

3. Install 1/2" NPT fittings (not included) into in-line strainer. (Wrap threads with teflon tape).

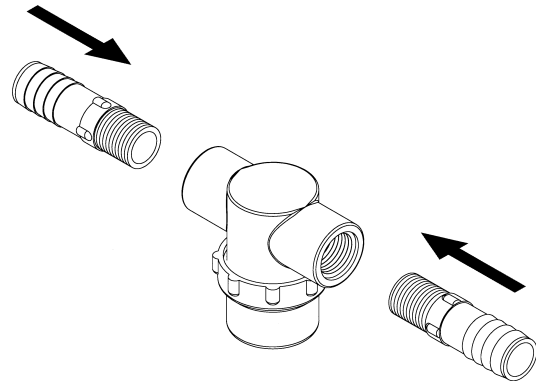

4. Attach hose from freshwater supply to inlet port of in-line strainer (#190601) (note arrow on strainer).
5. Attach hose from outlet port of in-line strainer (#190601) to hose barb fitting (#190405) in pump.

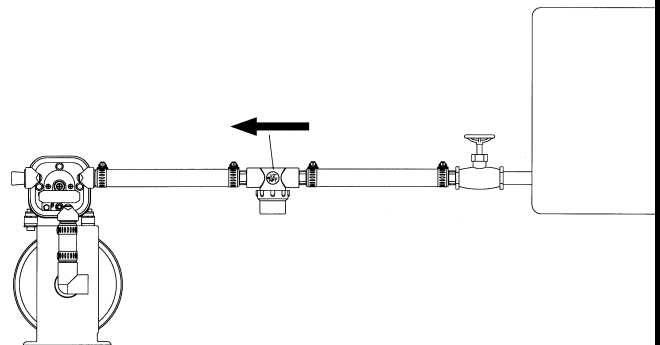

## WIRING

### WARNING: Hazard of Shock and Fire

- Always use proper wire, wire connectors and fuse/circuit breaker. See Specification Chart on page 4.
  - Secure wire properly.
  - Make sure power is off before proceeding.
  - Use proper wire terminals for all wire connections.
1. Determine proper size wire from Specification Chart on page 4. Measure distance from power source to the pump and back.
  2. Select proper size fuse/circuit breaker from Specifications Chart on page 4.
  3. Connect Red lead from Galley Flow System through a proper fuse/circuit breaker to DC electrical distribution panel (or positive battery terminal). Connect BLACK lead from Galley Flow System to negative battery terminal or negative DC bus.

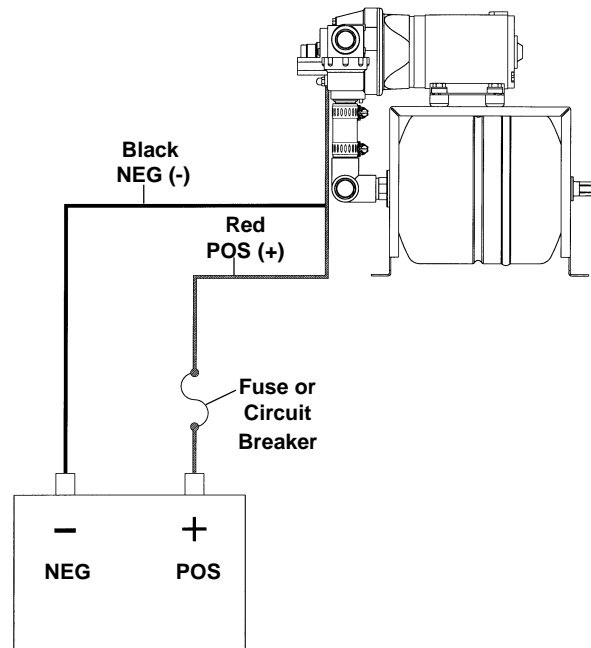



<b>TROUBLESHOOTING</b>		
<b>PROBLEM</b>	<b>POSSIBLE CAUSE</b>	<b>CONCLUSION</b>
<p>A. Pump will not prime or motor runs (humming noise) but pump not pumping water.</p>	<p>A1. Filter/strainer clogged.                      A2. Empty water tank.                      A3. Leak in pump water supply line.                      A4. Low Voltage.                       A5. Wiring.                       A6. Distance from water tank to pump is excessive.                      A7. Crack in pump housing.                      A8. Worn pump valves or diaphragm damaged.</p>	<p>A1. Clean filter/strainer.                      A2. Refill freshwater tank.                      A3. Check for leaks, tighten clamps or connections.                      A4. Check voltage at pump. If Voltage drop exceeds 10%, check terminals and wire connections for corrosion. Charge batteries.                      A5. Check gauge of wire to be sure it is not undersized.                      A6. Pump should be close to tank with lift not exceeding six feet (1.8M).                      A7. Replace housing or pump assembly.                      A8. Replace as needed.</p>
<p>B. Pump will not shut off.</p>	<p>B1. Low voltage.                      B2. Pressure switch failure.</p>	<p>B1. See A4 above.                      B2. Replace pressure switch.</p>
<p>C. System loses pressure and runs when faucets are closed.</p>	<p>C1. Worn pump valves or diaphragm.                      C2. Leak in system.</p>	<p>C1. Replace as needed.                      C2. Check plumbing system and pressure tank for leaks; Repair as necessary.</p>
<p>D. System cuts out while operating or will not start.</p>	<p>D1. Built-in thermal switch has been tripped.                      D2. Pressure switch failure.                      D3. Failed motor.</p>	<p>D1. Ventilate area well; Relocate pump if temperatures are likely to be in excess of 120°F (49°C).                      D2. Replace pressure switch.                      D3. Replace motor.</p>

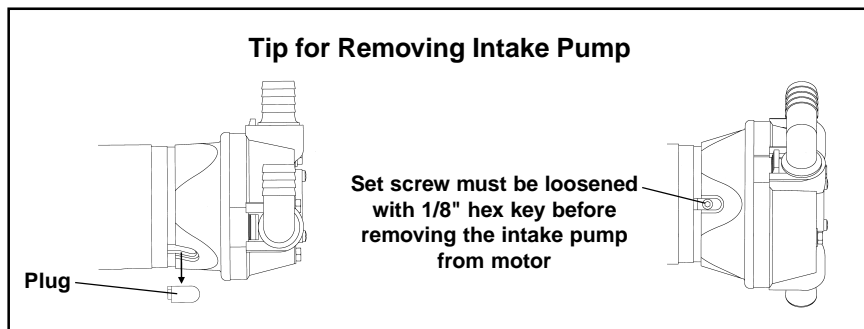

# EXPLODED PARTS

Galley Flow System EXPLODED PARTS

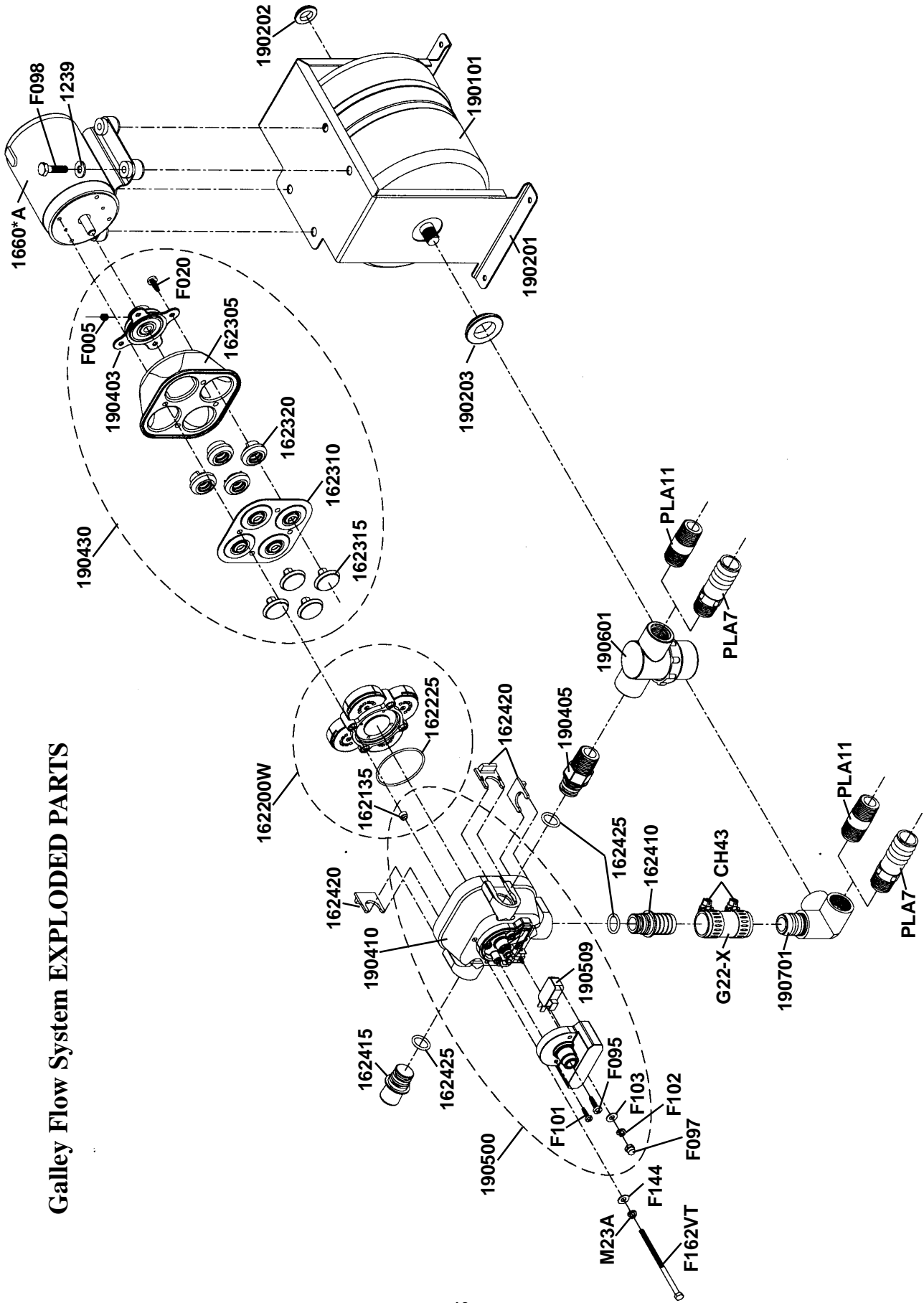

## Galley Flow System PARTS LIST

(Quantities are one unless otherwise indicated)

Before ordering, locate required part on exploded parts view to be sure you are ordering the correct part.

Part No.	Description	Part No.	Description
1239	1/4" Flat S/S Washer (4)	F097	1/4-20 x 1 Hex Hd Screw (4)
1660*A	Galley Flow Motor	F101	6-32 x 3/8 Hex Hd S/S Screw (2)
162135	Cone Seal (4)	F102	#6 Lockwasher S/S
162225	O-Ring	F103	#6 Flat Washer S/S
162305	Lower Housing includes 162315 (4)	F144	#10L 18-8 S/S Washer (4)
162310	Diaphragm includes 162315 (4)	F162VT	Mounting Bolt (4)
162315	Piston (4)	G22-X	3/4 NYL Reinforced Hose (sold by the foot)
162320	Piston Seat (4) includes 162315 (4)	M23A	Lockwasher (4)
162410	3/4" Hose Barb Straight	PLA7	Male Adapter 1/2 MPT x 3/4 Barb
162415	Plug Fitting	PLA11	1/2 x 2" Nipple
162420	Fitting Clip (3)	162200W	Middle Housing Assembly
162425	O-Ring (3)	190400	Galley Flow Inlet Pump Assembly includes 162200W, 190410, 190430
190101	Tank: .8 Gallon Steel with Internal Bladder	190403	Bearing Plate Assembly includes 162315 (4) and F005
190201	Mounting Frame for Tank	190410	Upper Housing Assembly includes 162135 (4)
190202	Rubber Grommet	190430	Lower Housing Assembly
190203	Rubber Grommet	190450	Pump and Pressure Switch Assembly includes 162200W, 162420 (3), 190430, 190500
190405	1/2" NPT Fitting	190500	Galley Flow Pressure Switch and Upper Housing Assembly
190509	Galley Flow Micro Switch	1910*	Galley Flow Pump with Motor, In-Line Strainer and Pressure Switch
190601	In-Line Strainer, Female		
190701	Side ell Sub-Assy. for Tank		
CH43	Hose Clamp #10 43H Series (2)		
F005	1/4-20 x 5/16 SS Hex SOC		
F020	#10 x 1/2 STSM Screw (4)		
F095	#8 x 3/4 Phil Pan Screw		
F097	Acorn Nut for Wire		

\* Specify Voltage (12V, 24V, 32V)

DIAPUMPRK Diaphragm Pump Repair Kit includes 162200W, 162310, 162315 (4), 162425 (3)

# EXPLODED PARTS

---

---

## LIMITED WARRANTY

Raritan Engineering Company warrants to the original purchaser that this product is free of defects in materials or workmanship for a period of one year from the product's date of purchase. Should this product prove defective by reason of improper workmanship and/or materials within the warranty period, Raritan shall, at its sole option, repair or replace the product.

1. TO OBTAIN WARRANTY SERVICE, Consumer must deliver the product prepaid, together with a detailed description of the problem, to Raritan at 530 Orange St., Millville, N.J. 08332, or 3101 SW 2nd Ave. Ft. Lauderdale, FL 33315. When requesting warranty service, purchaser must present a sales slip or other document which establishes proof of purchase. **THE RETURN OF THE OWNER REGISTRATION CARD IS NOT A CONDITION PRECEDENT OF WARRANTY COVERAGE.** However, please complete and return the owner Registration Card so that Raritan can contact you should a question of safety arise which could affect you.
2. THIS WARRANTY DOES NOT COVER defects caused by modifications, alterations, repairs or service of this product by anyone other than Raritan; defects in materials or workmanship supplied by others in the process of installation of this product; defects caused by installation of this product other than in accordance with the manufacturer's recommended installation instructions or standard industry procedures; physical abuse to, or misuse of, this product. This warranty also does not cover damages to equipment caused by fire, flood, external water, excessive corrosion or Act of God.
3. ANY EXPRESS WARRANTY NOT PROVIDED HEREIN, AND ANY REMEDY FOR BREACH OF CONTRACT WHICH BUT FOR THIS PROVISION MIGHT ARISE BY IMPLICATION OR OPERATION OF LAW, IS HEREBY EXCLUDED AND DISCLAIMED. ALL IMPLIED WARRANTIES SUCH AS THOSE OF MERCHANTABILITY AND OF FITNESS FOR A PARTICULAR PURPOSE, IF APPLICABLE, AS WELL AS ANY IMPLIED WARRANTIES WHICH MIGHT ARISE BY IMPLICATION OF LAW, ARE EXPRESSLY LIMITED TO A TERM OF ONE YEAR. SOME STATES DO NOT ALLOW LIMITATIONS ON HOW LONG A LIMITED WARRANTY LASTS, SO THE ABOVE LIMITATION MAY NOT APPLY TO YOU.
4. UNDER NO CIRCUMSTANCES SHALL RARITAN BE LIABLE TO PURCHASER OR ANY OTHER PERSONS FOR ANY SPECIAL OR CONSEQUENTIAL DAMAGES, WHETHER ARISING OUT OF BREACH OF WARRANTY, BREACH OF CONTRACT, OR OTHERWISE. SOME STATES DO NOT ALLOW THE EXCLUSION OR LIMITATION OF INCIDENTAL OR CONSEQUENTIAL DAMAGES, SO THE ABOVE LIMITATION OR EXCLUSION MAY NOT APPLY TO YOU.
5. No other person or entity is authorized to make any express warranty, promise or affirmation of fact or to assume any other liability on behalf of Raritan in connection with its products except as specifically set forth in this warranty.
6. This warranty gives you specific legal rights, and you may also have other rights which vary from state to state.



530 Orange Street, P.O. Box 1157, Millville, NJ 08332 USA  
Telephone: 856-825-4900 FAX: 856-825-4409  
[www.raritaneng.com](http://www.raritaneng.com)  
Southern Office and Plant:  
3101 SW Second Avenue, Fort Lauderdale, FL 33315 USA  
Telephone: 954-525-0378 FAX: 954-764-4370