

Cricket™ Manual Marine Toilet

Installation & Maintenance Instructions

THE FOLLOWING ARE CAUTIONARY STATEMENTS THAT MUST BE READ AND FOLLOWED DURING BOTH INSTALLATION AND OPERATION

WARNING: *Raritan Engineering Company, Inc. recommends that a qualified person or technician install this product. Equipment damage, injury to personnel or death could result from improper installation. Raritan Engineering Company, Inc. accepts no responsibility or liability for damage to equipment, or injury or death to personnel, that may result from improper installation or operation of this product.*



WARNING: Hazard of Flooding - Any installation made below the waterline must have vented loops positioned properly and all hose connections should be double-clamped. Both intake and discharge seacocks should always be in the closed position when the toilet is not in use. Failure to do so may result in flooding, property damage and loss of life.



INTRODUCTION

The **Cricket™** marine toilet uses a manually operated double-action diaphragm pump. Its size, appearance and simple installation make it ideal for small areas. Household-style space requirements are: 16 1/4" (41.3cm)H, 17" (43.2cm)W and 20" (50.8cm)D. Marine-size requirements are: 15 7/8" (40.3cm)H, 16 3/4" (42.6cm)W and 17" (43.2cm)D.

The **Cricket™** is suitable for use with Raritan's Lectra/San, a U.S. Coast Guard certified Type I flow-thru Marine Sanitation Device (MSD), and/or holding tank installations.

OPERATION

1. Always pump the toilet with a smooth, even stroke. It is advisable to flush the toilet briefly before using, to wet the inside of the bowl. With the dry pump lever in the vertical (wet bowl) position, extend the telescoping flush handle and pump it two or three times. A completely dry discharge cavity is more likely to clog than a wet cavity during normal usage.

NOTE: The dry pump lever is intended to be hand-operated.

CAUTION: Excessive force used while pumping the toilet may cause damage to the unit.

2. The pump is designed to bring in rinse water and discharge waste water at the same time. A built-in compensator assures that the pump always discharges more than it brings in. If the water level in the bowl should temporarily rise, move the dry pump lever to the horizontal (dry bowl) position, then pump for several strokes. Return the dry pump lever to the vertical position and pump a few strokes to clear all lines.

Water height in the bowl: Very little water will remain in the bowl under normal conditions unless a vented loop is installed in the discharge line (Fig. # 2).

CAUTIONS: Hard objects or stringy substances (paper towels, feminine hygiene products, filter tip cigarettes, etc.) thrown into the toilet will cause damage. These objects MUST NOT BE PLACED IN THE TOILET.

▲ WARNING: To avoid injury always return the operating handle to its retracted position when not in use. Never use the handle of the Cricket™ marine toilet to steady yourself on a pitching boat.

INSTALLATION

The **Cricket™** marine toilet can be installed above or below the water line. However, for mounting at or

below the water line **vented loops must be installed as shown in Fig. #2 to prevent back siphoning.** All thru-hull fittings should include readily accessible seacocks for safety and to simplify maintenance. (This recommendation is made by marine underwriters for all installations.)

1. Mount the unit securely on a flat solid deck (see Fig. #3 for mounting template measurements) using stainless steel bolts, nuts and large washers or use lag screws long enough not to pull out.
2. Use 3/4" (19 mm) I.D. reinforced hose for intake connections and 1 1/2" (38 mm) I.D. sanitation hose (#SH available from Raritan) for discharge.
3. Fittings and 90 degree bends should be kept to a minimum to maintain proper performance.

SUGGESTIONS:

- A. The use of a Raw Water Strainer (#RWS), on the inlet line is recommended. This will help keep odors down and prevent clogging.
- B. Intake and discharge thru-hull fittings (if used) should be as far apart as practical, preferably on opposite sides of the keel. This will help to minimize the possibility of discharge water being drawn back into the intake.

MAINTENANCE

With normal use very little maintenance is required other than inspection and periodic replacement of rubber parts. Using C.P. (#1PCP22), a bio-enzymatic toilet bowl cleaner (available from Raritan Engineering) will keep the bowl clean and fresh smelling.

Introducing Raritan Concentrate into flush water through a Toilet Water Kit (#TWK) will deodorize and lubricate the unit.

CAUTIONS: Using improper deodorants or cleaners can result in damage to rubber and plastic parts. DO NOT USE products containing pine oil, formaldehyde, phosphoric acid, chlorine or any solvent or petroleum-based products.

A 3/32" Allen Wrench has been included in the owners packet for removal of flush handle assembly set screw (#F149VT) if needed.

Before attempting repairs, refer to the Troubleshooting section of this manual.

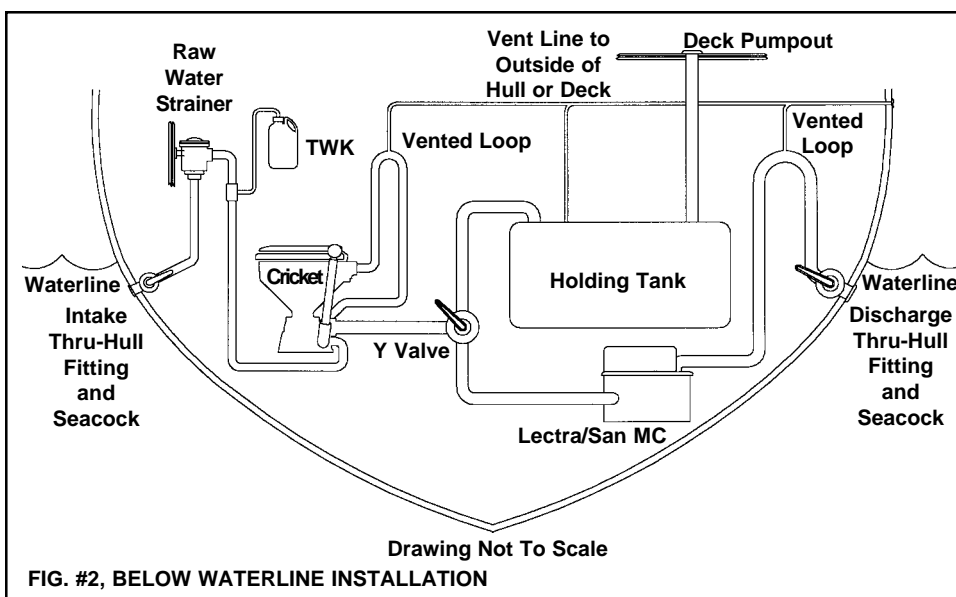
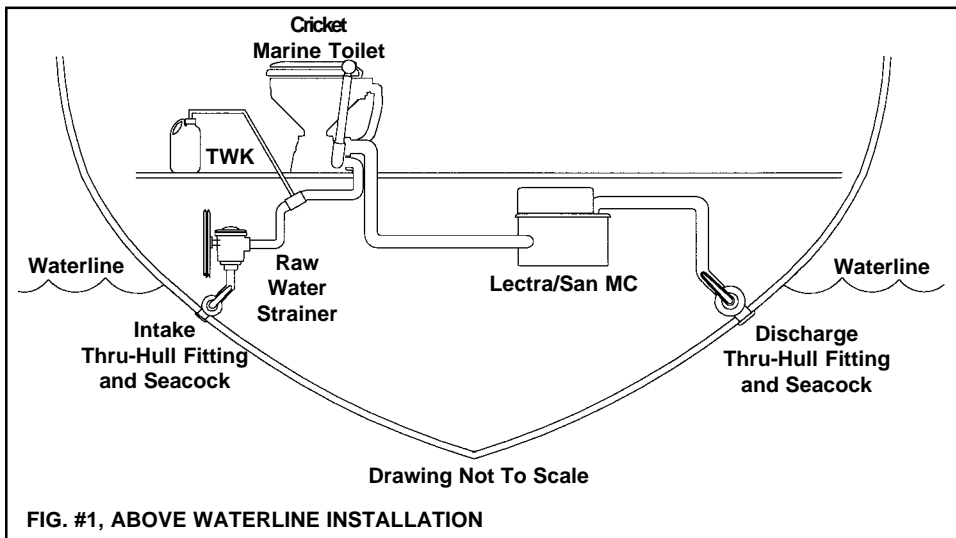

STORAGE

When boat is not in use, flushing the system with fresh water will help minimize odors and reduce mineral and scale build-up.

WINTERIZATION

CAUTION: Use only non-toxic antifreeze.

Improper winter lay up is a major cause of marine toilet failures.

1. Close the intake and discharge seacocks. Disconnect and drain the intake and discharge hoses. Winterize seacocks and hoses.
2. You will need two buckets, three feet (1m) of 3/4" (19 mm) hose, three feet (1m) of 1 1/2" (38 mm) hose and a quart (1 liter) of non-toxic antifreeze.
3. Prepare one half gallon (1.9 liters) of an antifreeze/water mixture in a bucket (refer to the antifreeze instructions for antifreeze/water ratio). Place intake hose in this bucket. Place discharge hose into the empty bucket. Pump toilet until antifreeze has circulated and is being discharged.
4. Antifreeze should remain in toilet until recommissioning. This will protect intake and discharge sides of the pump. Pouring antifreeze into the bowl will only protect the discharge side of the pump, allowing the intake side to possibly freeze.

NOTE: Holding tanks, seacocks and treatment systems will have to be independently winterized, stored and recommissioned (see manufacturer's instructions).

RECOMMISSIONING

When danger of freezing has passed, reconnect intake hoses and open seacock. (Failure to open seacocks and attempting to operate unit can cause damage to toilet.) Flush out the antifreeze into a bucket. Be sure to dispose of antifreeze in accordance with local, state and federal regulations.

Reconnect discharge hose. Check connections for leaks with several test flushes. Follow "Operation" instructions.

TROUBLESHOOTING

Before attempting repairs be sure you have studied this manual and parts list thoroughly and have checked the terms of the Limited Warranty.

If you have questions please contact our Technical Support Department in either Millville, NJ or Ft. Lauderdale, FL.

CAUTION: Before working on toilet or whenever leaving the boat unattended be sure that both intake and discharge seacocks are closed.

Ordering replacement parts: Individual parts and a repair kit (#CKRK) are available through your dealer, distributor, direct from the factory, or at www.raritaneng.com.

Units requiring extensive repairs may be returned to the Millville, N.J. or Fort Lauderdale, FL. office. Instructions, including name, address and phone number **MUST** accompany returned units to ensure proper handling.

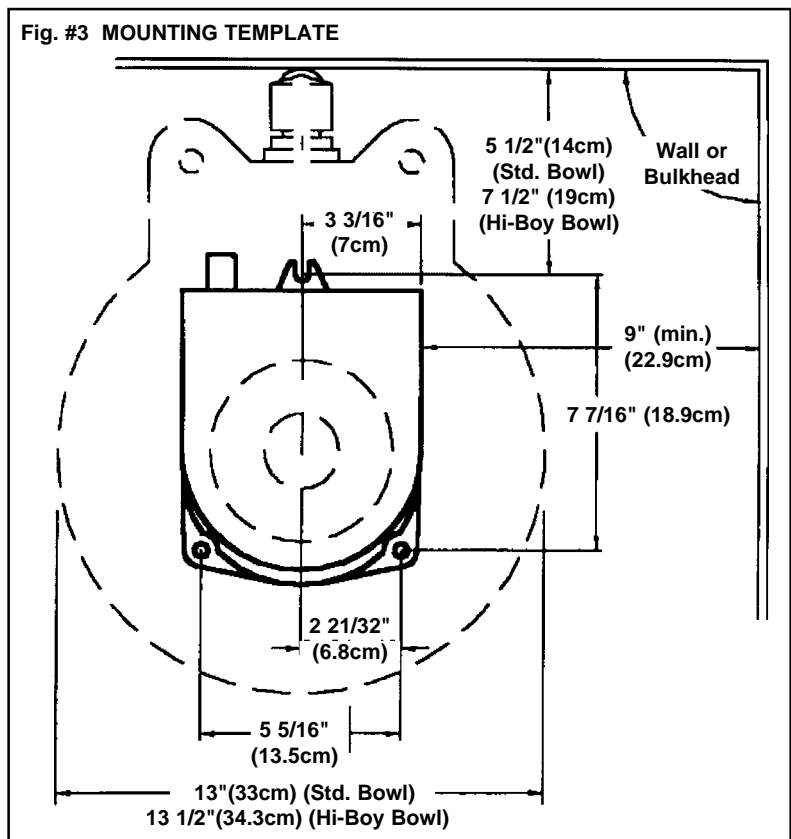

TROUBLESHOOTING

PROBLEM	POSSIBLE CAUSE	CORRECTION
A. Water accumulates in the bowl faster than it pumps out.	A1. Lodged debris. A2. Joker Valve not closing. A3. Holding Tank is pressurized.	A1. Clear any lodged debris. See #2 under "Operation". A2. Check Joker Valve for wear and debris. Clean or replace. A3. Clogged holding tank or loop vent; clean vent.
B. Water rises in the bowl when the boat is at dockside.	B1. Discharge Joker Valve leaking (backflow). B2. Dry Pump Lever leaking. B3. Air pocket in discharge line.	B1. If leaking stops when discharge seacock is closed, clean or replace the joker valve. If leaking continues make sure the vented loops are installed properly and vents are functional. B2. Make sure no debris is in the inlet flapper valve, clean or replace as necessary. Install an In-Line Strainer (#163000) and/or vented loop (see Figures #2). B3. Bleed or clean vent fitting of vented loop or holding tank.
C. Intake water flow is poor and/or water builds up in the bowl.	C1. Intake line clogged. C2. Cracked or worn out bowl throat flapper.	C1. Clear intake line, check for build up in hose. C2. Replace bowl base flapper (#1455A).
D. Leak around handle socket.	D1. Seal leaking.	D1. Replace the Cricket Drive Shaft Seal (#1214A). See literature L229a.
E. A persistent and obnoxious odor comes from the toilet bowl.	E1. Eel grass lodged in bowl. E2. Foul intake water. E3. Full holding tank. E4. Worn joker valve. E5. Discharge line clogged. E6. Improper or contaminated discharge hose.	E1. Connect a garden hose to the spud at the back of the bowl and flush it out under pressure. E2. Add a Raritan (#TWK) to deodorize intake water. E3. Empty Holding tank, be sure vent is clean and functional. E4. Replace joker valve. E5. Clear any debris lodged in discharge. E6. If hose has foul odor, replace with proper sanitation hose.
F. Watersquirts out breather hole behind bowl. (See "A" on exploded parts view)	F. Hole in Compensator.	F. Replace Compensator.
G. Flush handle jams in mid-stroke.	G1. Intake line is clogged. G2. Joker Valve is clogged.	G1. Clear intake line, check for buildup in line. Consider installing an In-Line Strainer (#163000). G2. If the Joker Valve is clogged, the bowl base flapper (#1455A) acts as a safety valve and releases back into the bowl. See H below.
H. Backflow appears to generate from bottom of bowl.	H1. Joker Valve is clogged.	H1. If the Joker Valve is clogged, the bowl base flapper (#1455A) acts as a safety valve and releases back into the bowl. Before the unit can be used again, the flapper needs to be placed back into its' operational position. This requires using a non-sharp object, such as a broom handle, to push the flapper back down into the bowl. (A sharp object could puncture or tear the flapper). Once the flapper is "reset" the clog needs to be cleared before the unit will properly operate. It is recommended that a moderate amount of toilet paper is used during each use.

Exploded View and Parts List

(Quan. 1 unless noted)

Part #	Part Name
1210A	Cotter Pin (3/32" D. x 1/2" L.) S/S
1213B	Delrin Washer
1213C	Seal Snap Ring (#6000-100 BC)
1214A	Shaft Seal
1222AW	90° Discharge W/flange
1222B	Straight Discharge Fitting (optional)
1226B	1/4-20 Hex Nut, S/S (4)
1236AW	Bowl Spud Assy (not shown)
1237W	Standard Bowl Assembly, incl. 1236AW (not shown)
1238A	Standard Seat and Cover (not shown)
1239	#14 Small Pattern S/S Washer
1326	1" White Gloss PVC Hose, 11 1/2" long
1328A	Bowl Elbow
1405W	Lower Housing
1406	Upper Housing
1407	Hose Clamp, white nylon #22HC 1250 (2)
1408	"O" Ring (#006, 70 Durometer) (Dry Pump Handle Shaft Screw)
1409	Bowl Seal "O" Ring (#331, 70 Durometer)
1410	Separator Plate
1415A	Diaphragm
1415AW	Diaphragm Assembly (incl. #1415A and #1417)
1416	Compensator
1417	Flapper Weight
1420	Piston
1425	Piston Plate
1430	Internal Lever
1435	Drive Shaft
1440W	Inlet Flapper Assembly (incl. #1441 flapper weight)
1445	Dry Pump Cam
1450	Dry Pump Lever
1451	"O" Ring, Dry Pump Handle Shaft
1455	Bowl Throat Flapper (white neoprene)
1456	Flapper Hold Down
1470	Handle Socket
1471W	Outer Flush Handle Assy. (incl. #1473 bushing)
1472	Inner Flush Handle (threaded)
1473	Flush Handle Bushing (not shown)
1475	Flush Handle Ball Grip
1476	Handle Socket "O" Ring (#210, 70 Durometer)
1477W	Flush Handle Assembly, Complete
1490W	Dry Flush Extension Kit (not shown)
162425	O-Ring
C253	Joker Valve
CH38	Bowl Stud, 1/4-20 x 2" S/S (4)
CKRK	Cricket Overhaul Kit Contains - 1210A, 1213B, 1213C, 1214A, 1239, 1408, 1409, 1415W, 1416, 1440W, 1451 (2), 1455, 1476, C254 and RNI (4)
F003	Clevis Pin (1/4 Dia. x 1 1/2" long, 3/32 hole) S/S
F004	E-Ring, S/S (#1200-37SS2)
F006	Dry Flush Handle Screw, S/S (#6-32 x 1 3/8" Hex Washer Head)
F007	Discharge Screw, S/S (3/8"-16 x 1" Hex Hd) (2)
F008	Self-Tapping Screw, S/S (#10 x 5/8" RH Philips)(4)
F091	Self-Tapping Screw, S/S (#10 x 3/4" RH Philips)
F092NP	Handle Socket Mounting Screw, S/S (1/4-20 x 5/8" RHMS)
F149VT	Set Screw, S/S (#10-32 x 1/4")
HTTHS	Pump Assembly Screw, S/S (#10-32 x 1/2"RHMS) (10)
RNI	Bowl Mounting Shoulder Washer (4)
VCAP	Vinyl Cap for Bowl Mounting Nuts (not shown)(4)

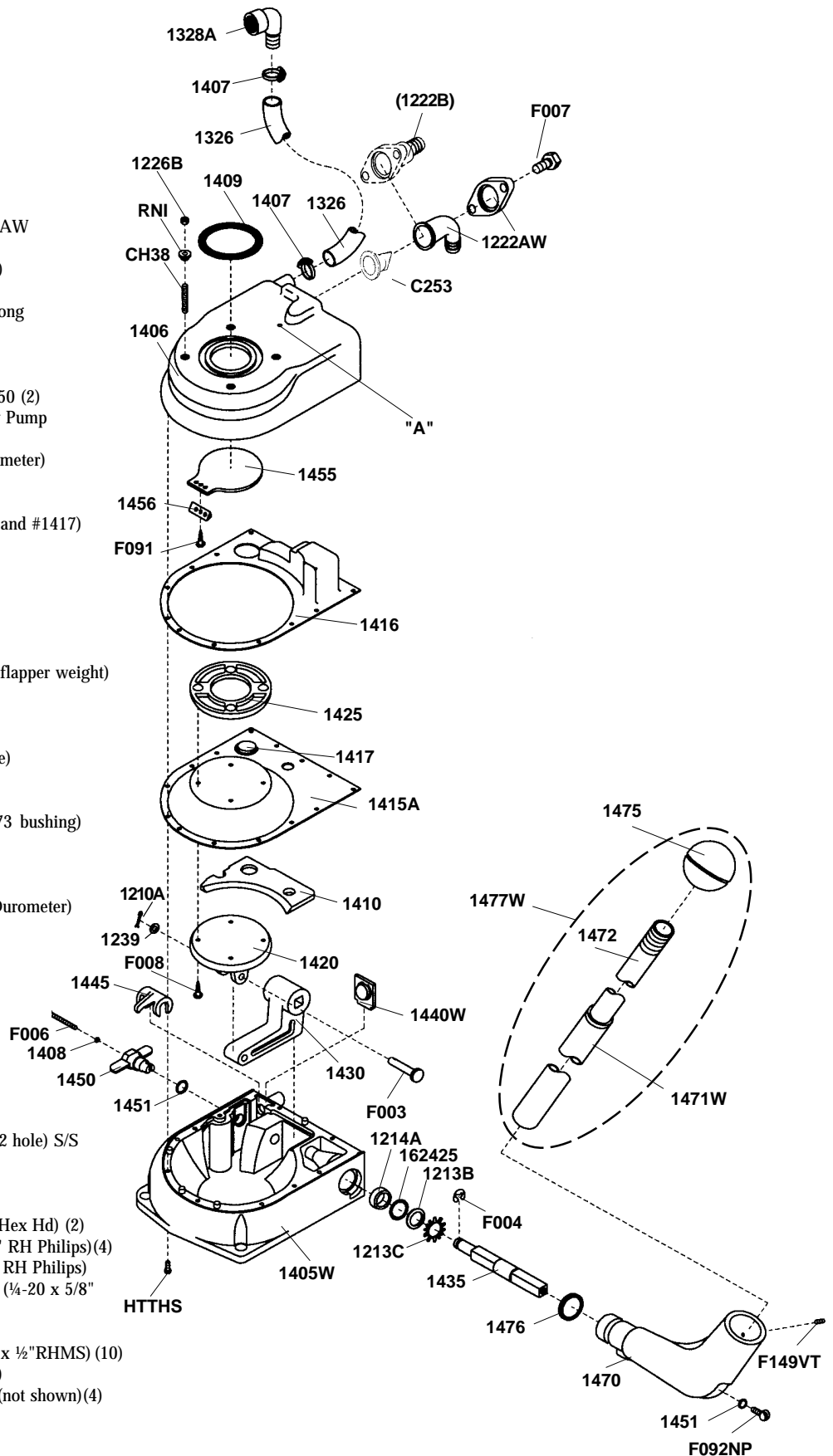

SPECIFICATIONS

Standard space requirements are:
15 7/8" (40.3 cm) Height,
16 3/4" (42.6 cm) Width and
17" (43.2 cm) Depth.

Hi-Boy space requirements are:
16 1/4" (41.3 cm) Height,
17" (43.2 cm) Width and
20" (50.8 cm) Depth.

Manually Flushed Toilet: Salt water or fresh water
Fitting Sizes: 3/4" intake and 1 1/2" discharge
Maximum Intake Hose Lift: 36" (1 m)
Maximum Intake Hose Length: 15' (4.6 m)
Maximum Discharge Hose Lift: 5' (1.5 m)
Maximum Discharge Hose Length: 15' (4.6 m)

LIMITED WARRANTY

Raritan Engineering Company warrants to the original purchaser that this product is free of defects in materials or workmanship for a period of one year from the product's date of purchase. Should this product prove defective by reason of improper workmanship and/or materials within the warranty period, Raritan shall, at its sole option, repair or replace the product.

1. TO OBTAIN WARRANTY SERVICE, Consumer must deliver the product prepaid, together with a detailed description of the problem, to Raritan at 530 Orange St., Millville, N.J. 08332, or 3101 SW 2nd ave Ft. Lauderdale, FL 33315. When requesting warranty service, purchaser must present a sales slip or other document which establishes proof of purchase. THE RETURN OF THE OWNER REGISTRATION CARD IS NOT A CONDITION PRECEDENT OF WARRANTY COVERAGE. However, please complete and return the owner Registration Card so that Raritan can contact you should a question of safety arise which could affect you.

2. THIS WARRANTY DOES NOT COVER defects caused by modifications, alterations, repairs or service of this product by anyone other than Raritan; defects in materials or workmanship supplied by others in the process of installation of this product; defects caused by installation of this product other than in accordance with the manufacturer's recommended installation instructions or standard industry procedures; physical abuse to, or misuse of, this product. This warranty also does not cover damages to equipment caused by fire, flood, external water, excessive corrosion or Act of God.

3. ANY EXPRESS WARRANTY NOT PROVIDED HEREIN, AND ANY REMEDY FOR BREACH OF CONTRACT WHICH BUT FOR THIS PROVISION MIGHT ARISE BY IMPLICATION OR OPERATION OF LAW, IS HEREBY EXCLUDED AND DISCLAIMED. ALL IMPLIED WARRANTIES SUCH AS THOSE OF MERCHANTABILITY AND OF FITNESS FOR A PARTICULAR PURPOSE, IF APPLICABLE, AS WELL AS ANY IMPLIED WARRANTIES WHICH MIGHT ARISE BY IMPLICATION OF LAW, ARE EXPRESSLY LIMITED TO A TERM OF ONE YEAR. SOME STATES DO NOT ALLOW LIMITATIONS ON HOW LONG A LIMITED WARRANTY LASTS, SO THE ABOVE LIMITATION MAY NOT APPLY TO YOU.

4. UNDER NO CIRCUMSTANCES SHALL RARITAN BE LIABLE TO PURCHASER OR ANY OTHER PERSONS FOR ANY SPECIAL OR CONSEQUENTIAL DAMAGES, WHETHER ARISING OUT OF BREACH OF WARRANTY, THE EXCLUSION OR LIMITATION OF INCIDENTAL OR CONSEQUENTIAL DAMAGES, SO THE ABOVE LIMITATION OR EXCLUSION MAY NOT APPLY TO YOU.

5. No other person or entity is authorized to make any express warranty, promise or affirmation of fact or to assume any other liability on behalf of Raritan in connection with its products except as specifically set forth in this warranty.

6. This warranty gives you specific legal rights, and you may also have other rights which vary from state to state.



RARITAN
Engineering Company, Inc.

530 Orange Street, P.O. Box 1157, Millville, NJ 08332 USA
Telephone: 856-825-4900 FAX: 856-825-4409
www.raritaneng.com
Southern Office and Plant:
3101 SW Second Avenue, Fort Lauderdale, FL 33315 USA
Telephone: 954-525-0378 FAX: 954-764-4370