

MEC-O-MATIC Dolphin Series

Metering Pumps



Chemical solution and slurry metering pumps designed, engineered and built to last.



- Exclusive quick-release, twist-off, clear polycarbonate, acid-resistant head to withstand the harshest environment.
- Self-lubricating chemical resistant roller assembly.
- Durable, long lasting tubing with no tube adjustment.
- Rugged and dependable ... heavy-duty shaded pole gearmotor with lifetime lubrication.
- Flexibility in feed rates ... from .13 gallons to 97 gallons per day ... to meet the demands of the pool and spa industry, and elsewhere.
- Agency approvals available.

Dolphin Model	Customary Units (60 Hz)					Metric Units (50 Cycle Line Frequency)					
	Max Feed Rate		Max. PSI	Rev. Per Min.	Ship Wt. lbs.	AMPS		AMPS 50Hz 240V	Max. Pressure KG CMF	Max. Feed Rate	
	G.P.D.	CC per min.				60Hz 120V	60Hz 240V			L/H	CC/Min
10	13	34	25	10	6.2	.42	.30	.35	2.0	1.75	29
50	60	158	25	50	6.9	.62	.34	.40	2.0	8.7	145
75	97	255	25	75	6.9	.72	.36	.42	2.0	12.4	207

- COOLING TOWERS
- SWIMMING POOLS
- BOILERS
- AGRICULTURE
- LAUNDRIES
- LIVESTOCK
- FOOD PROCESSING
- RESIDENTIAL WATER TREATMENT
- CAR WASHES

- PHOTO PROCESSORS
- METAL FINISHING
- WAREWASHING

technology
innovation
diversity
excellence

Dolphin Series Specifications

Chemical Metering Pumps

PUMP CASE

The pump case is molded of a rugged, chemical-resistant ABS. Mounting pads and a built-in wall mounting bracket allow a choice of flat surface or wall mounted installation.

GEARMOTOR

The thermal or impedance protected gearmotor is safe, quiet and dependable. All metal gearing parts are heat-treated and the output shaft is supported by heavy duty bearings. Gearmotors are available for 120V 60Hz or 240V 50/60Hz operation.

FEEDER HEAD

The feeder head is molded of UV and acid resistant polycarbonate and is designed to snap on and off without tools.

TUBING

Manufactured and selected specifically for durability, the peristaltic tubing on the Dolphin Series is agency tested. Optional tubing materials are available for special applications.

TIMER

A 10-minute solid-state electric current interrupter is a standard feature, built into every Dolphin Series feed pump.

ACCESSORIES

15 feet of 1/4" O.D. poly tubing, an auto-clean check valve injection point fitting, a strainer with weights, and an installation manual are included with each unit.

WARRANTY

The manufacturer warrants the equipment of its manufacture to be free of defects in material or workmanship. Liability under this policy extends for eighteen (18) months from the date of purchase or one (1) year from date of installation or whichever comes first. The manufacturer's liability is limited to repair or replacement of any device or part which is returned, prepaid, to the factory and which is proven defective upon examination. This warranty does not include installation or repair cost and in no event shall the manufacturer's liability exceed its selling price of such part.

The manufacturer disclaims all liability for damage to its products through improper installation, maintenance, use or attempts to operate such products beyond their functional capacity, intentionally or otherwise, or any unauthorized repair. Replaceable elastomeric parts are expendable and are not covered by any warranty either expressed or implied. The manufacturer is not responsible for consequential or other damages, injuries, or expense incurred through use of its products.

The above warranty is in lieu of any other warranty, either expressed or implied. The manufacturer makes no warranty of fitness or merchantability. No agent of ours is authorized to make any warranty other than the above.

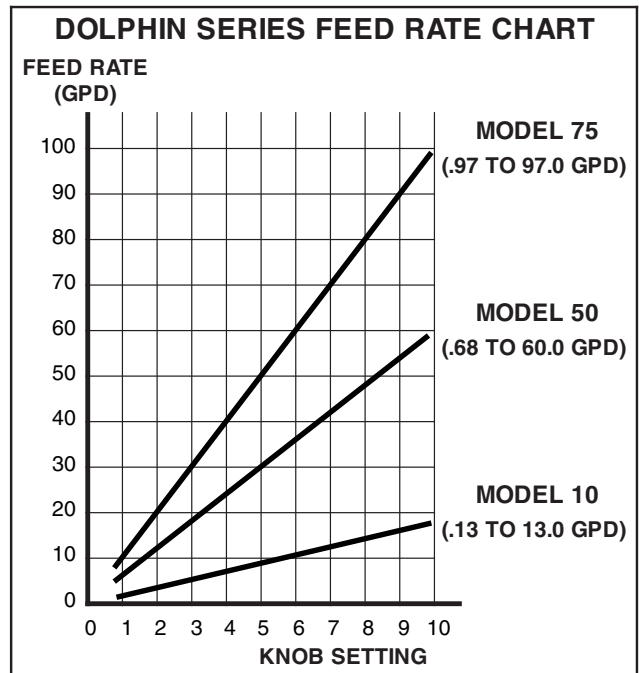

DIMENSIONS

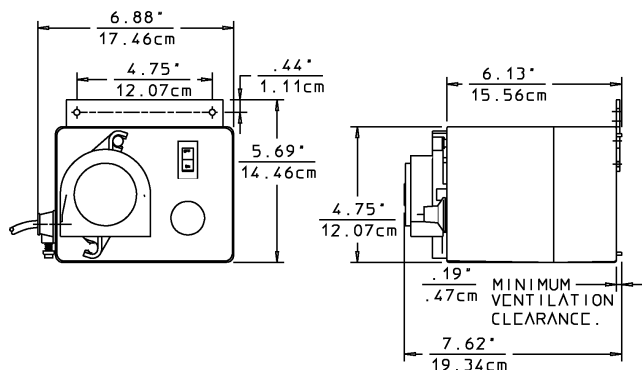

An ISO Certified Company



A Unit of IDEX Corporation

NOVA-TECH
INTERNATIONAL

800 Rockmead Dr Ste 120 • Houston, TX 77339-2151
Tel: (281) 359-8538 • Toll Free Tel: (866) 433-6682
Fax: (281) 359-8192 • Toll Free Fax: (866) 433-6684
sales@novatech-usa.com • www.novatech-usa.com