

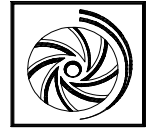

# PRICE PUMP CO.

## XT/XL PARTS LIST

Effective: May 17, 2001



### For Sizes:

- 1 x 1½ 6
- 1½ x 2 - 6 (Threaded Only)
- 1½ x 3 - 6 (Flanged Only)
- 2 x 3 - 6

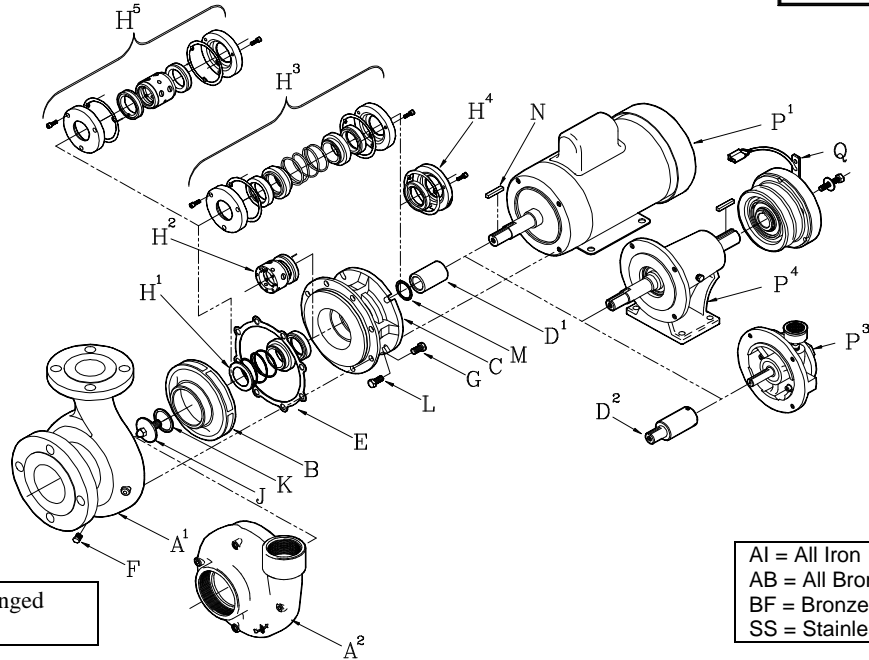

AI = All Iron
AB = All Bronze
BF = Bronze Fitted
SS = Stainless Steel

Note: Pumps available in Threaded or Flanged Connections as noted below

	<u>AI Threaded</u>	<u>BF Threaded</u>	<u>AB Threaded</u>	<u>SS Threaded</u>	<u>SS Flanged</u>
<b>A.</b> Volute					
1 x 1-1/2 - 6 (XT100 Threaded, XL100 Flanged)	2601	2601	2603	2629	2605
1-1/2 x 2 - 6 (XT150 Threaded)	2607	2607	2609	2626	
1/2 x 3 - 6 (XL150 Flanged)					2611
2 x 3 - 6 (XT200 Threaded, XL200 Flanged)	2613	2613	2615	2627	2617
<b>B.</b> Impeller Specify diameter **					
1 x 1-1/2 - 6 (XT100 Threaded, XL100 Flanged)	2602-dia	2604-dia	2604-dia	2606-dia	2606-dia
1-1/2 x 2 - 6 (XT150 Threaded)	2608-dia	2610-dia	2610-dia	2612-dia	
1-1/2 x 3 - 6 (XL150 Flanged)					2612-dia
2 x 3 - 6 (XT200 Threaded, XL200 Flanged)	2614-dia	2616-dia	2616-dia	2618-dia	2618-dia
<b>Note:</b> For Dbl seal add DS (Sample: 2614 <b>DS</b> -dia)					
<b>C.</b> Bracket (std)	0131	0131	0132	0979	0979
Double Seal	0131-1	0131-1	N/A	0979-1	0979-1
Single Flush	0131-2	0131-2	0132-2	0979-2	0979-2
Quench	0131-3	0131-3	N/A	0979-3	0979-3
Internal Flush	0131-4	0131-4	N/A	0979-4	0979-4
Bracket for 213/215 JM	3405	3405	N/A	3388	3388
O-ring	3405-0	3405-0	N/A	N/A	N/A
Double Seal	2405-1	3405-1	N/A	3388-1	3388-1
Single Flush	3405-2	3405-2	N/A	3388-2	3388-2
Quench	3405-3	3405-3	N/A	3388-3	3388-3
Internal Flush	3405-4	3405-4	N/A	3388-4	3388-4
Internal Flush w/ Quench	3405-5	3405-5	N/A	3388-5	3388-5
<b>D<sup>1</sup>.</b> Shaft Sleeve (for std JM motor)	0127	0126	0126	0127	0127
<b>D<sup>2</sup>.</b> Stub Shaft 5/8" ID (56C) opt	0329-1	0329-1	0329-1	0329-1	0329-1
<b>D<sup>3</sup>.</b> Stub Shaft 7/8" ID (143TC/145TC/182C/184C) option (Not Shown)	0328-1	0328-1	0328-1	0328-1	0328-1
<b>E.</b> Volute Gasket	0124 (Syn Fiber)	0124 (Syn Fiber)	0124 (Syn Fiber)	0301 (PTFE)	0301 (PTFE)
<b>F.</b> Pipe Plug (2 rqd Threaded, 1 rqd Flanged)	0557	0557	0558	0559	0559
<b>G.</b> Volute Bolts (8 rqd)	0583	0583	0587	0724	0724
<b>H<sup>1</sup>.</b> T.21 Single Seal/Seat	0121 (std B*)	0121 (std B*)	0121 (std B*)	0122 (std V*)	0122 (std V*)

B\* = Buna

V\* = Fluorocarbon

\*\*For Double Seal Impellers (add "DS" to Impeller P/N For Example: 2602DS)

Continued on Back...

### Price® Pump Company

21775 8th Street East ♦ P.O. Box Q ♦ Sonoma, CA 95476-0329 ♦ (707) 938-8441 ♦ Fax (707) 938-0764

# XT/XL PARTS LIST

Effective: May 17, 2001

Continued

<u>All Models</u>		
H <sup>2</sup> .	T.9 PTFE Single Seal/Seat (opt)	0123
	Seat Pin T.9 (not shown)	0890
H <sup>3</sup> .	T.21 Double Seal/Seat (opt)	Specify P/N
	Double Seal Plate (2 rqd)	0309
	Plate Gasket, PTFE (2 rqd)	0505
	Plate Bolts (6 rqd)	0977
H <sup>4</sup> .	Seal Quench (opt):	
	Buna Lip Seal	0756
	Fluorocarbon Lip Seal	0757
	PTFE Lip Seal	0758
	Lip Seal Plate	0309-2
	Plate Gasket, PTFE	0505
	Plate Bolts (3 rqd)	0977
H <sup>5</sup> .	T.9 PTFE Double Seal/Seat (opt)	0670
	Double Seal Plate (2 rqd)	0309-1
	Plate Gasket, PTFE (2 rqd)	0505
	Plate Bolts (6 rqd)	0977
	Seat Pin T.9 (2 rqd not shown)	0890
J.	Impeller Lockdown	0978
K.	Lockdown Gasket, PTFE	0245

<u>All Models</u>		
L.	Motor Bolts	
	All Bronze pumps (4 rqd)	0587
	Stainless Steel pumps (4 rqd)	0593
	AI & BF pumps (4 rqd) and order Washers (4 rqd)	0593 1137
	Motor Bolts for 3405 & 3388 brackets	
	All Bronze pumps	N/A
	Stainless Steel pumps (4req)	1189
	AI & BF pumps (4 req) and order Washers (4 req)	1189 1199
M.	Sleeve Gasket, PTFE	0245
N.	Impeller Shaft Key	0135
P <sup>1</sup> .	JM Motor	Specify P/N
P <sup>2</sup> .	'C' Face Motor (not shown) Base Plate (not shown)	Specify P/N 0199
P <sup>3</sup> .	Air Motor	Specify P/N
P <sup>4</sup> .	Power Frame	5480
Q.	12 Volt Clutch (opt)	1983
	Key for Clutch (2 ea)	0136
	Lockbolt for Clutch	0567
	Lockbolt Washer for Clutch	0564

### XL/XT Repair Parts Kits

All Iron	P/N 0659	Syn. Fiber Gasket - SS Shaft Sleeve - Sleeve Gasket - Loctite - Imp. Lockdown Gasket
CIBF	P/N 0658	Syn. Fiber Gasket - BR Shaft Sleeve - Sleeve Gasket - Loctite - Imp. Lockdown Gasket
SS	P/N 1019	PTFE Gasket - SS Shaft Sleeve - Sleeve Gasket - Loctite - Imp. Lockdown Gasket
<b>Note: Seal/seat must be ordered in addition to repair kit.</b>		
Options: 1½" T.21 & T.9 Single & Double.		

**Price® Pump Company**

21775 8th Street East ♦ P.O. Box Q ♦ Sonoma, CA 95476-0329 ♦ (707) 938-8441 ♦ Fax (707) 938-0764