



General Terms Of Sale For Products

1. GENERAL

A. Seller's price is based on these sales terms and conditions. This contract shall represent the final, complete and exclusive statement of the agreement between the parties and may not be modified, supplemented, explained or waived by parol evidence, any Terms and Conditions contained in Buyer's purchase order or request for quotation, any course of dealings between the parties, Seller's performance or delivery, or in any other way. The Terms and Conditions of this contract may only be modified or waived in a written document signed by an Officer of Seller. These terms are intended to cover all activity of Seller and Buyer hereunder, including sales and use of products, parts and work and all related matters (references to products include parts and references to work include construction, installation and start-up). Any reference by Seller to Buyer's specifications and similar requirements are only to describe the products and work covered hereby and no warranties or other terms therein shall have any force of effect. Any information provided by Seller, including but not limited to suggestions as to specific equipment does not imply any guarantee of specific suitability and/or material compatibility in a particular application since many factors outside the control of Seller may affect the suitability of products in a particular application. Catalogs, circulars and similar pamphlets of the Seller are issued for general information purposes only and shall not be deemed to modify the provisions hereof.

B. The agreement formed hereby and the language herein shall be construed and enforced under the Uniform Commercial Code as in effect in the State of California on the date hereof.

2. TAXES

Any sales, use or other similar type taxes imposed on this sale or on this transaction are not included in the price. Such taxes shall be billed separately to the Buyer. Seller will accept a valid exemption certificate from the Buyer if applicable; however, if an exemption certificate previously accepted is not recognized by the governmental taxing authority involved and the Seller is required to pay the tax covered by such exemption certificate. Buyer agrees to promptly reimburse Seller for the taxes paid.

3. PERFORMANCE, INSPECTION AND ACCEPTANCE

A. Unless Seller specifically assumes installation, construction or start-up responsibility, all products shall be finally inspected and accepted within thirty (30) days after arrival at point of delivery. Products not covered by the foregoing and all work shall be finally inspected and accepted within thirty (30) days after completion of the applicable work by Seller. All claims whatsoever by Buyer (including claims for shortages) excepting only those provided for under the WARRANTY AND LIMITATION OF LIABILITY and PATENTS Clauses hereof must be asserted in writing by Buyer within said thirty (30) day period or they are waived. If this contract involves partial performance, all such claims must be asserted within said thirty- (30) day period for each partial performance. There shall be no revocation of acceptance. Rejection may be only for defects substantially impairing the value of products or work and Buyer's remedy for lesser defects shall be those provided for under the WARRANTY AND LIMITATION OF LIABILITY Clause.

B. Seller shall not be responsible for non-performance or for delays in performance occasioned by any causes beyond Seller's reasonable control, including, but not limited to, labor difficulties, delays of vendors or carriers, fires, governmental actions, or shortages of material, components, labor, or manufacturing facilities. Any delays so occasioned shall affect a corresponding extension of Seller's performance dates, which are, in any event, understood to be approximate. In no event shall Buyer be entitled to incidental or consequential damages for late performance or for a failure to perform. Seller reserves the right to make partial shipments and to ship products, parts or work which may be completed prior to the scheduled performance date.

C. In the event that Seller has agreed to mount motors, turbines, gears, or other products which are not manufactured by Seller and which are not an integral part of Seller's manufactured product, and a delay in the delivery of such products to Seller occurs that will cause a delay in Seller's performance date, Seller reserves the right to ship its product upon completion of manufacture and to refund an equitable portion of the amount originally included in the purchase price for mounting without incurring liability for non-performance.

D. Seller reserves to itself the right to change its specifications, drawings and standards if such changes will not impair the performance of its products, and parts, and further that such products, and parts, will meet any of Buyer's specifications and other specific product requirements which are a part of this agreement.

E. The manufacture and inspection of products and parts shall be to Seller's Engineering and Quality Assurance standards plus such other inspections, tests or documentation as are specifically agreed to by Seller. Requirements for any additional inspection, tests, documentation, or Buyer witness of manufacture, test, and/or inspection shall be subject to additional charges.

4. TITLE AND RISK OF LOSS

Title and risk of loss shall pass to buyer upon delivery of products at the designated Ex Works place (Incoterms 1990) unless other wise agreed by the parties.

5. EROSION AND CORROSION

It is specifically understood that products and parts sold hereunder are not warranted for operation with erosive or corrosive fluids. No product or part shall be deemed to be defective by reason of failure to resist erosive or corrosive action of any fluid and Buyer shall have no claim whatsoever against Seller therefore.

6. WARRANTY AND LIMITATION OF LIABILITY

A. Seller warrants only that its product and parts, when shipped, will be free from defects in materials and workmanship. With respect to products and parts not manufactured by Seller, Seller's only obligation shall be to assign to Buyer, to the extent possible, whatever warranty Seller requires from the manufacturer. All claims for defective products or parts under this warranty must be made in writing immediately upon discovery and, in any event, within one (1) year after initial start-up or eighteen (18) months after shipment, whichever first occurs, and all claims for defective work must be made in writing immediately upon discovery and in any event, within one (1) year of completion thereof by Seller.

Defective items must be held for Seller's inspection and returned to the original f.o.b. point upon request. THE FOREGOING IS EXPRESSLY IN LIEU OF ALL OTHER WARRANTIES WHATSOEVER, EXPRESS, IMPLIED AND STATUTORY, INCLUDING WITHOUT LIMITATION, THE IMPLIED, WARRANTIES OF MERCHANTABILITY AND FITNESS.

B. ANY PRODUCT (S) SOLD HEREUNDER WHICH IS NOT MANUFACTURED BY SELLER IS NOT WARRANTED BY SELLER and shall be covered only by the express warranty, if any, of the manufacturer thereof.

C. Upon Buyer's submission of a claim as provided above and its substantiation, Seller shall at its option either (i) repair or replace its product, part or work at the original place of delivery, or (ii) refund an equitable portion of the purchase price.

D. THE FOREGOING IS SELLER'S ONLY OBLIGATION AND BUYER'S EXCLUSIVE REMEDY FOR BREACH OF WARRANTY AND, EXCEPT FOR GROSS NEGLIGENCE, WILLFUL MISCONDUCT, AND REMEDIES PERMITTED UNDER THE PERFORMANCE, INSPECTION AND ACCEPTANCE AND THE PATENTS CLAUSES HEREOF, THE FOREGOING IS BUYER EXCLUSIVE REMEDY AGAINST SELLER FOR ALL CLAIMS ARISING HEREUNDER OR RELATING HERETO WHETHER SUCH CLAIMS ARE BASED ON BREACH OF CONTRACT, TORT (INCLUDING NEGLIGENCE) OR OTHER THEORIES. BUYER'S FAILURE TO SUBMIT A CLAIM AS PROVIDED ABOVE SHALL SPECIFICALLY WAIVE ALL CLAIMS FOR DAMAGES OR OTHER RELIEF, INCLUDING BUT NOT LIMITED TO CLAIMS BASED ON LATENT DEFECTS. IN NO EVENT SHALL BUYER BE ENTITLED TO INDIRECT, SPECIAL, INCIDENTAL OR CONSEQUENTIAL DAMAGES, NOR FOR DAMAGES FOR LOSS OF USE, LOST PROFITS OR REVENUE, INTEREST, LOST GOODWILL, WORK OR PRODUCTION STOPPAGE, IMPAIRMENT OF OTHER GOODS, INCREASED EXPENSES OF OPERATION, OR THE COST OF PURCHASING REPLACEMENT POWER OR OTHER SERVICES BECAUSE OF SERVICE INTERRUPTIONS. FURTHERMORE, IN NO EVENT SHALL SELLER'S TOTAL LIABILITY FOR DAMAGES OF BUYER EXCEED THE PURCHASE PRICE OF THE PRODUCTS OR PARTS MANUFACTURED BY SELLER AND UPON WHICH SUCH LIABILITY IS BASED. ANY ACTION ARISING HEREUNDER RELATED HERETO, WHETHER BASED ON BREACH OF CONTRACT, TORT (INCLUDING NEGLIGENCE) OR OTHER THEORIES, MUST BE COMMENCED WITHIN ONE (1) YEAR AFTER THE CAUSE OF ACTION ACCRUES OR IT SHALL BE BARRED.

7. PURCHASER'S REPRESENTATIONS & WARRANTIES

Purchaser represents and warrants that the products(s) covered by this contract shall not be used in or in connection with a nuclear facility or application. The parties agree that this representation and warranty is material and is being relied on by seller. This provision may be modified in a separate writing signed by an officer of PPC.

8. PATENTS

Seller agrees to assume the defense of any suit for infringement of any patents brought against Buyer to the extent of such suit charges infringement of an apparatus or product claim by Seller's product in and of itself, provided (i) said product is built entirely to Seller's design, (ii) Buyer notifies Seller in writing of the filing of such suit within ten (10) days after the service of process thereof, and (iii) Seller is given complete control of the defense of such suit, including the right to defend, settle and make changes in the product for the purpose of avoiding infringement of any process or method claims, unless infringement of such claims is the result of following specific instruction furnished by Seller.

9. EXTENT OF SUPPLY

Only products as listed in Seller's proposal are included in this agreement. It must not be assumed that Seller has included anything beyond same.

10. MANUFACTURING SOURCES

To maintain delivery schedules, Seller reserves plants on a world-wide basis.

11. TERMS OF PAYMENT

Net 30 days from date of invoice.



Price® Pump Company

Type XT/XL Installation, Operating and Maintenance Manual

Caution:
Before installing, repairing or performing maintenance on this pump, read these instructions completely.

If pump has been used to pump hazardous materials be certain that all materials have been removed prior to working on the pump.

Warning!!
Ground motor before connection to electrical power supply!! Failure to ground motor can cause severe or fatal electrical shock hazard!!

Do not ground to gas supply line!!

Match voltage to nameplate voltage on motor. Incorrect voltage can cause fire or seriously damage motor, voiding warranty.

Before disassembling be certain all liquid is removed from the pump.

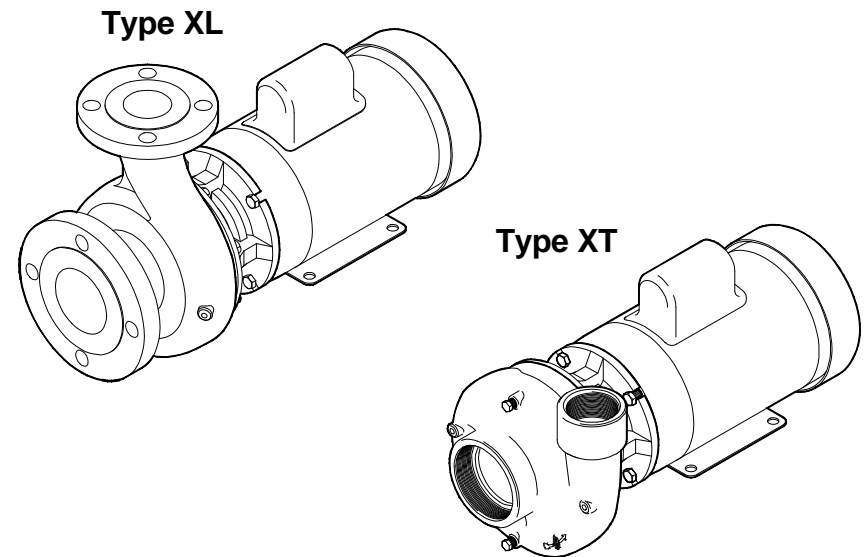

Effective: January 1, 1999

Close Coupled Motor Pumps

These pumps require no special care in mounting, although it is suggested that they be firmly bolted to a level surface. Adequate air movement over motor will help prevent overloads.

Power Frame Mounted Pumps

These pumps must be mounted on a rigid steel base that will not warp or flex. Each pump must be mounted such that **the pump shaft centerline is on center with the driver shaft centerline.** Pad and/or shims will be required on either pump, driver or both. The two shafts should not touch each other and the distance between them depends on the coupling used to connect them. **Misalignment will cause bearing failure and void warranty. Pumps are rough aligned at the factory but must be realigned after shipment and installation.** Pulley driven pump must have pulleys inline and good belt tightness practices followed.

Direction of Rotation

Note: Motor shaft rotation is viewed from the suction end of pump. A rotational arrow is shown on the front of the pump volute casing. Incorrect rotation can cause pump damage, failure or reduced performance, voiding warranty. It is best to check rotation by

momentarily energizing or jogging the motor prior to filling pump with liquid.

Warning! Do not operate pump without liquid for more than a few seconds, as damage will result to mechanical seal.

PLUMBING

All piping should be supported independently of the pump. Piping should not exert any stress on the pump connections.

Suction Piping Horizontal Pumps

Suction line must provide adequate suction pressure and smooth liquid flow for proper pump operation. Air entrapment in the suction line because of leaks or improper design may cause the pump to lose prime and fail. This pump is not self-priming, therefore the suction must be flooded at start up. Also, the suction line must provide sufficient pressure and smooth flow to pump inlet to prevent pump cavitation. A length of straight pipe a minimum of 5 times the pump inlet diameter and preferably 10 times the diameter should be installed in the suction line where it enters the pump. Elbows, fittings or valves installed close to the suction can disrupt liquid flow and cause malfunction. Suction lines must be at least the same size as the pump inlet or larger if possible.

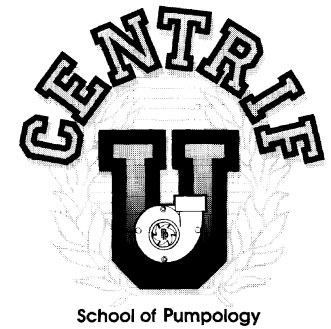

Visit Our Web Site
www.pricepump.com

- * Check out The Centrifugal Pump University and take the Interactive Pump Test.
- * Find technical information for all Price Pump models.
- * Locate a local distributor at www.pumpnet.com
- * Printable I&O Manuals in PDF Format.

Parts List Type XT/XL Cont.

	<u>All Models</u>		<u>All Models</u>	
H2.	T.9 Teflon® Single Seal/Seat (opt) Seat Pin T.9 (not shown)	0123 0890	J. K.	Impeller Lockdown Lockdown Gasket, Teflon®
H3.	T.21 Double Seal/Seat (opt) Double Seal Plate (2 rqd) Plate Gasket, Teflon® (2 rqd) Plate Bolts (6 rqd)	Specify P/N 0309 0505 0977	L.	Motor Bolts All Bronze pumps (4 rqd) Stainless Steel pumps (4 rqd) AI & CIBF pumps (4 rqd) and order Washers (4 rqd)
H4.	Seal Quench (opt): Buna Lip Seal Viton® Lip Seal Teflon® Lip Seal Lip Seal Plate Plate Gasket, Teflon® Plate Bolts (3 rqd)	0756 0757 0758 0309-2 0505 0977	M. N. P1. P3. P4.	Sleeve Gasket, Teflon® Impeller Shaft Key JM Motor Air Motor Power Frame
H5.	T.9 Teflon® Double Seal/Seat (opt) Double Seal Plate (2 rqd) Plate Gasket, Teflon® (2 rqd) Plate Bolts (6 rqd) Seat Pin T.9 (2 rqd not shown)	0670 0309-1 0505 0977 0890		Specify P/N Specify P/N 5480

Price Pump Co. recommends against using foot valves in the suction line to maintain liquid in the pump when it's not operating. If foot valves are used due to suction lift conditions they must be properly maintained to avoid leaks resulting from wear or fouling. Suction piping must be designed to prevent air from being trapped in high spots in the piping. This condition may cause the pump to vapor lock as the air bubble moves into the pump.

Discharge Piping

For flow and discharge head control it is advisable to install a valve (globe, ball, or other adjustable and non-leak type) in the discharge line close to the pump. The valve may be closed during system repairs to prevent backflow. By installing a check valve in the discharge line backflow can also be prevented during maintenance or during periods of pump stoppage.

OPERATION

Priming-
All centrifugal pumps must be filled with liquid prior to start up. For the pump illustrated in this manual completely fill the volute and suction lines prior to operation. It is suggested that during initial start up the discharge valve be closed and then opened as the motor develops full rpm's. If pump does not build up pressure as motor

speed increases, shut down and make sure that liquid flow into pump is not restricted (see "Troubleshooting").

Note: A centrifugal pump's flow and head (pressure) will vary with the amount of resistance (friction and flow restrictions) in the discharge line. As a valve on the discharge line opens the flow and motor amp draw will increase and head will drop. As a valve on the discharge is closed the flow and amp draw will decrease and the head will increase. If resistance in the discharge line is not sufficient the pump will operate at a condition of maximum (or "choked") flow, also sometimes called "end of performance curve." Maximum horsepower is required to operate at this point and motor overload may result. If excessive amp draw and motor overload is recurring, reduce the system flow by installing a valve on the discharge line and restricting flow. Alternatively, reduce pump head by trimming impeller to a smaller diameter. Consult local Price Pump dealer for assistance.

TROUBLESHOOTING

1. Pump fails to build pressure:

Check for:

- Pump not primed.
- Incorrect rotation.
- Driver speed too low.
- Suction line restricted.
- Driver failure.
- Plugged or damaged impeller.
- Pump or impeller undersized.
- Pump cavitation.
- Improper impeller clearance.

2. Pump fails to provide enough flow.

Check for:

- System resistance too high.
- Pump undersized.
- Pump not primed.
- Driver speed too low.
- Poor suction conditions.
- Improper impeller clearance.

3. Excessive noise or vibration during operation.

Check for:

- Motor bearing failing.
- Pump cavitating.
- Improper impeller clearance.

4. Leaking mechanical seal.

Check for:

- Improper assembly.
- Worn or cracked seal faces.
- Abrasive material in fluid.
- Liquid flashing at seal faces (fluid temperature too high).
- Seal pressure rating too low for the service.
- Chemical attack of seal parts.
- Seal operated dry or with a liquid having poor lubricating properties.

5. Pump gradually loses pressure and head.

Check for:

- Increasing temperature causing cavitation or liquid vaporization.
- Driver failure.
- Suction lift too high.
- Air entering suction line.

6. Motor/pump overheating.

Check for:

- Excessive flow and amp draw (Throttle discharge).
- Low voltage or frequency.
- Flow too low with resulting heat rise.
- Bearing failure.
- System temperature too high.

Parts List Type XT/XL

	<u>AI Threaded</u>	<u>BF Threaded</u>	<u>AB Threaded</u>	<u>SS Threaded</u>	<u>SS Flanged</u>
A. Volute					
XT/XL 100	2601	2601	2603	2629	2605
XT/XL 150	2607	2607	2609	2626	2611
XT/XL 200	2613	2613	2615	2627	2617
B. Impeller Specify diameter					
XT/XL 100	2602-dia	2604-dia	2604-dia	2606-dia	2606-dia
XT/XL 150	2608-dia	2610-dia	2610-dia	2612-dia	2612-dia
XT/XL 200	2614-dia	2616-dia	2616-dia	2618-dia	2618-dia
Note: For Dbl seal add DS (Sample: 2614DS-dia)					
C. Bracket (std)	0131	0131	0132	0979	0979
Double Seal	0131-1	0131-1	N/A	0979-1	0979-1
Single Flush	0131-2	0131-2	0132-2	0979-2	0979-2
Quench	0131-3	0131-3	N/A	0979-3	0979-3
Internal Flush	0131-4	0131-4	N/A	0979-4	0979-4
Shaft Sleeve	0127	0126	0126	0127	0127
D1. Stub Shaft 5/8" ID	0329-1	0329-1	0329-1	0329-1	0329-1
D2. Stub Shaft 7/8" ID	0328-1	0328-1	0328-1	0328-1	0328-1
D3. Volute Gasket	0124	0124	0124	0301	0301
E. Pipe Plug	0557	0557	0558	0559	0559
F. Volute Bolts	0583	0583	0587	0724	0724
G. T.21 Seal/Seat	0121	0121	0121	0122	0122

Continued on next page

Type XT/XL Parts List

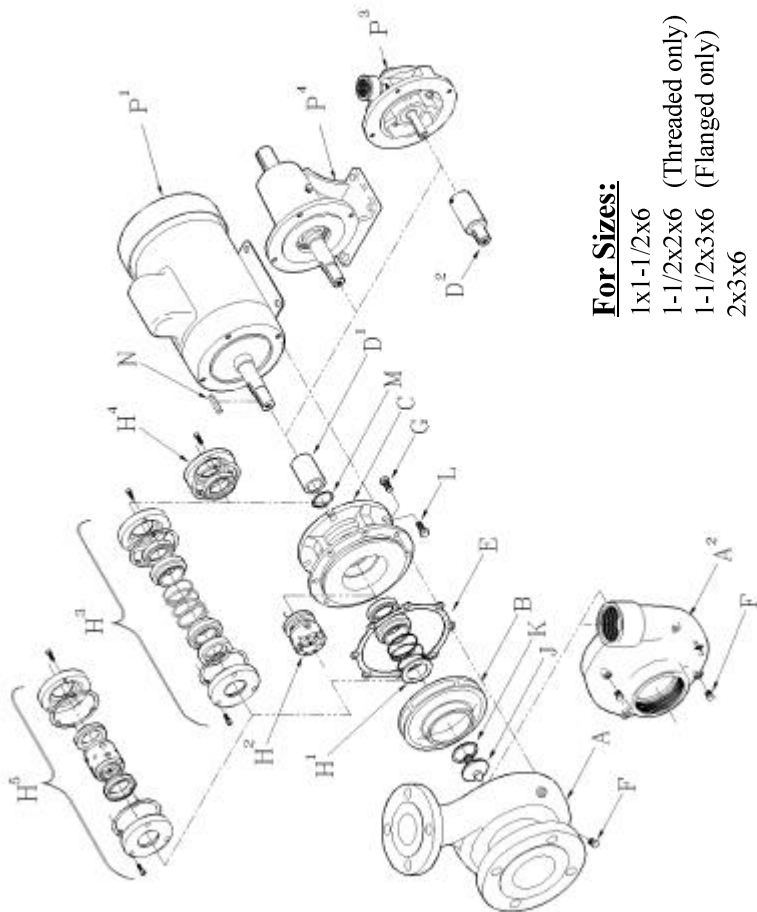

For Sizes:

- 1x1-1/2x6
- 1-1/2x2x6 (Threaded only)
- 1-1/2x3x6 (Flanged only)
- 2x3x6

- AI = All Iron
- BF = Bronze Fitted
- AB = All Bronze
- SS = Stainless Steel

TYPE XT/XL MAINTENANCE AND REPAIR

DISASSEMBLY

1. Disconnect power source from motor.
2. Disconnect electrical connections, tagging wires carefully to preserve correct rotation. Loosen pump base.
3. Remove pump and motor assembly to repair area. Observe position of all parts prior to disassembly.
(Note: volute may be left in piping.)
4. Remove 8 volute bolts and remove volute from pump.
5. Remove impeller. Remove impeller lockdown by turning CCW. Slide impeller off of the shaft. Save shaft key.
6. Remove seal head from the shaft. On type 9 seal, loosen set screws and slide seal from shaft. On type 21, remove seal by sliding it off of the shaft.
7. Remove the four motor bolts and remove bracket from motor.
8. Remove seal seat from bracket. Use wooden or plastic dowel to tap the seat from the bracket. Diagram A
9. Remove shaft or shaft sleeve. Heat shaft sleeve to approximately 300°F and use a bearing puller to remove the sleeve.

REASSEMBLY

1. Clean seal cavity of the bracket thoroughly.
2. Thoroughly clean pump shaft. Assure that the shaft is not grooved and that there is no evidence of pitting or fretting. Polish the shaft with extra fine emery cloth and clean the keyway.
- 3a. On 56C motors, (stub shaft pumps only), ensure all debris and burrs are removed from the motor shaft. Align halfdog setscrew with motor keyway while sliding stub shaft over the motor shaft. Set height (diagram A). Tighten all set screws.

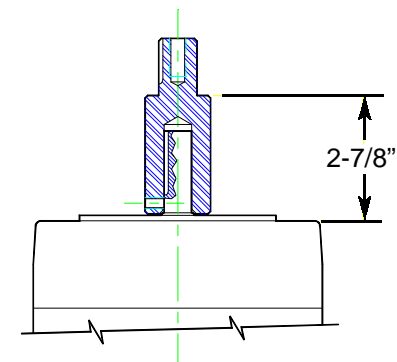

Reassembly Instructions
continued on next page →

3b. On JM style motors, apply Loctite RC/609 to inside diameter of shaft sleeve. Install shaft sleeve onto motor shaft making sure that the groove for the Teflon® sleeve gasket is facing the pump end. Clean excess Loctite from shaft. Be sure sleeve is seated against motor shaft shoulder.

4. For Type 21, 8, and 9 seals: Place the bracket on a firm surface with the seat cavity (pump end) up. Then place a small amount of vegetable oil on the seat cup or "O" ring seat. Place the seat in the seal cavity with the polished face up toward the pump end. Evenly push seat into seat cavity with fingers, then then gently tap seat into place with a wooden dowel or plastic rod (2" outside diameter). To help ensure the seat is not damaged, place the cardboard disk supplied with the seal under the end of the dowel to prevent damaging the seat face.

5. Place bracket on motor (aligning the base if applicable). Secure bracket to motor with four motor bolts and washers.

6. Install seal head assembly:

For Type 21:

a. Lubricate shaft and elastomer with vegetable oil.

b. Install rotary seal head onto pump shaft and slide toward seat using a twisting motion until carbon face touches seal seat.

c. For 145JM through 215JM frame pumps, install new sleeve gasket into shaft sleeve. For 254JM through 256JM, install new gasket into hub of impeller.

d. Install seal spring and retainer over shaft sleeve.

e. Install impeller onto motor shaft being careful to align keyway of impeller with keyway in motor shaft. Push impeller on until impeller bottoms out on shaft sleeve. Install key in keyway.

f. Install impeller lockdown gasket and impeller lockdown. Tighten securely.

For Type 8 or Type 9:

a. Do not remove metal clips from seal head assembly. Place seal on shaft sleeve sliding gently past shoulder.

b. Slide seal head toward seat until carbon face contacts ceramic seat. Tighten seal head setscrews to shaft sleeve using short arm allen wrench supplied with seal or repair kit. Remove clips in seal head and discard.

c. For 145JM through 215JM frame pumps, install new sleeve gasket into shaft sleeve. for 254JM through 256JM, install new gasket into hub of impeller.

d. Install impeller onto motor shaft, being careful to align keyway of impeller with keyway in motor shaft. Push impeller on until impeller bottoms out on shaft sleeve. Install key in keyway.

e. Install impeller lockdown gasket and impeller lockdown. Tighten securely.

7. Install new volute gasket. Ensure that all of the mating surfaces of the gasket joint are cleaned to bare metal.

8. Install volute and secure with 8 bolts and tighten evenly.

9. Rotate pump shaft by hand to ensure impeller does not rub against volute.

10. Return pump to installation, reconnect electric connections.

11. Start pump momentarily to observe shaft rotation. If rotation corresponds to the rotation arrow on the pump, it may be put into service. If rotation is incorrect, switch any two leads on 3-phase motors to change rotation. Check wiring diagram of

motor for single phase rotation correction.

12. Remove top pipe plug (if applicable) from the front of volute and prime pump thoroughly, making sure all air is purged. Turn shaft one revolution and then refill. Replace the pipe plug.

13. Start pump allowing adequate time to purge all air from system. Observe any gauges, flow meters, etc., to see if pump performs properly.