



PRICE PUMP Installation, Operating, and Maintenance Manual

Type MS50SS

Caution:
Before installing,
repairing or performing
maintenance on this
pump, read these
instructions completely.

Installation Electrical

WARNING!
**Ground motor before
connecting to electrical
power supply! Failure to
ground motor can cause
severe or fatal electrical
shock hazard!**

**Do not ground to gas
supply line!**

**Disconnect power to
motor before working on
motor or pump!**

**Match voltage to
nameplate voltage on
motor. Incorrect voltage
can cause fire or seriously
damage motor, voiding
warranty.**

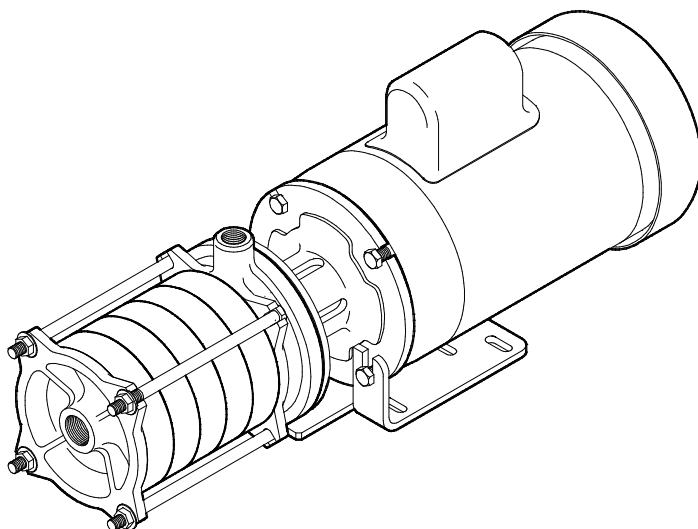

Close Coupled - Motor Pumps

These pumps require no special care in mounting, although it is suggested that they be firmly bolted to a level surface. Adequate air movement over motor will help prevent overloads.

Power Frame Mounted Pumps

These pumps must be mounted on a rigid steel base that will not warp or flex. Each pump must be mounted such that **the pump shaft centerline is on center with the driver shaft center-line.** Pads and/or shims will be required on either pump, driver or both. The two shafts should not touch each other and the distance between them depends on the coupling used to connect them. **Misalignment will cause bearing failure and void warranty. Pumps are rough aligned at the factory but must be realigned after shipment and installation.** Pulley driven pumps must have pulleys in line and good belt tightness practices followed.

Direction of Rotation

Note: Motor shaft rotation is viewed from the suction end of pump. A rotational arrow is shown on the front of the pump volute casing. Incorrect rotation can cause pump damage, failure or reduced performance, voiding warranty. It is best to check rotation by **momentarily** energizing or jogging the motor prior to filling pump with liquid.

Warning! Do not operate pump without liquid for more than a few seconds, as damage will result to mechanical seal.

PLUMBING

All piping should be supported independently of the pump. Piping should not exert any stress on the pump connections.

1. Suction Piping-Horizontal Pumps.

Suction line must provide adequate suction pressure and smooth liquid flow for proper pump operation. Air entrapment in the suction line because of leaks or improper design may cause the pump to lose prime and fail. This pump is not self-priming, therefore the suction must be flooded at start up. Also, the suction line must provide sufficient pressure and smooth flow to pump inlet to prevent pump cavitation. A length of straight pipe a minimum of 5 times the pump

inlet diameter and preferably 10 times the diameter should be installed in the suction line where it enters the pump. Elbows, fittings or valves installed close to the suction can disrupt liquid flow and cause malfunction. Suction lines must be at least the same size as the pump inlet or larger if possible. Price Pump Company recommends against using foot valves in the suction line to maintain liquid in the pump when it's not operating. If foot valves are used due to suction lift conditions they must be properly maintained to avoid leaks resulting from wear or fouling. Suction piping must be designed to prevent air from being trapped in high spots in the piping. This condition may cause the pump to vapor lock as the air bubble moves into the pump.

2. Discharge Piping.

For flow and discharge head control it is advisable to install a valve (globe, ball, or other adjustable and non-leak type) in the discharge line close to the pump. The valve may be closed during system repairs to prevent backflow. By installing a check valve in the discharge line backflow can also be prevented during maintenance or during periods of pump stoppage.

pump head by trimming impeller

OPERATION

Priming. All centrifugal pumps must be filled with liquid prior to start up. For the pump illustrated in this manual completely fill the volute and suction lines prior to operation. It is suggested that during initial start up the discharge valve be closed and then opened as the motor develops full rpm's. If pump does not build up pressure as motor speed increases, shut down and reprime pump. Make sure that liquid flow into pump is not restricted (see "Troubleshooting").

Note: A centrifugal pump's flow and head (pressure) will vary with the amount of resistance (friction and flow restrictions) in the discharge line. As a valve on the discharge line opens the flow and motor amp draw will increase and head will drop. As a valve on the discharge is closed the flow and amp draw will decrease and the head will increase. If resistance in the discharge line is not sufficient the pump will operate at a condition of maximum (or "choked") flow, also sometimes called "end of performance curve." Maximum horsepower is required to operate at this point and motor overload may result. If excessive amp draw and motor overload is recurring, reduce the system flow by installing a valve on the discharge line and restricting flow. Alternatively, reduce to a smaller diameter. Consult

local Price Pump dealer for assistance.

CAUTION

Disconnect power to pump before servicing to avoid dangerous or fatal electrical shock hazards.

If pump has been used to pump hazardous materials be certain that all materials have been removed prior to working on the pump.

Inverting pump with liquid in it could cause liquid to get into motor bearings and cause damage. Before disassembling be certain all liquid is removed from the pump.

TROUBLESHOOTING

1. Pump fails to build pressure:

Check for:

- a. Pump not primed.
- b. Incorrect rotation.
- c. Driver speed too low.
- d. Suction line restricted.
- e. Driver failure.
- f. Plugged or damaged impeller.
- g. Pump or impeller undersized.
- h. Pump cavitation.
- i. Impeller rubbing volute.

2. Pump fails to provide enough flow.

Check for:

- a. System resistance too high.
- b. Pump undersized.
- c. Pump not primed.
- d. Driver speed too low.
- e. Poor suction conditions
- f. Impeller rubbing volute due to improper installation.
- g. Pump cavitation.
- h. Plugged or damaged impeller.

3. Excessive noise or vibration during operation.

Check for:

- a. Motor bearing failing.
- b. Pump cavitating.
- c. Impeller rubbing volute.

4. Leaking mechanical seal.

Check for:

- a. Improper assembly.
- b. Worn or cracked seal faces.
- c. Abrasive material build up around seal.
- d. Liquid flashing at seal faces (temp too high).
- e. Seal pressure rating too low for the service.
- f. Chemical attack of seal parts.
- g. Seal operated dry or with a liquid having poor lubricating properties.

5. Pump gradually loses pressure and head.

Check for:

- a. Increasing temperature causing cavitation or liquid vaporization.
- b. Driver failure.
- c. Suction lift too high.
- d. Air entering suction line.

6. Motor/pump overheating.

Check for:

- a. Excessive flow and amp draw. (Throttle discharge)
- b. Low voltage or frequency.
- c. Flow too low with resulting heat rise.
- d. Bearing failure.
- e. System temperature too high.

Before attempting any repairs under warranty, contact Distributor to obtain factory authorization. Repairs carried out without authorization may void warranty. Many causes of pump system failure are due to improper system design. Refer to the Trouble Shooting List in this manual before carrying out pump inspection.

DISASSEMBLY

1. Disconnect power source to motor.
2. Disconnect electrical connections tagging wires carefully to preserve correct rotation. Loosen motor base.
3. Remove pump and motor assembly to repair area. Observe position of all parts prior to disassembly.
4. Remove stage connector bolts.
5. Remove suction plate.
6. Loosen impeller setscrews and remove impeller by sliding off pump shaft.
7. Slide diffuser off of pump shaft.
8. Remove stage separator and O-ring.
9. Repeat steps 5 through 7 until last impeller is removed from the pump shaft.
10. Remove seal head from pump. Type 21: slide seal head from the shaft. Type 9: Loosen set screws and slide seal head off shaft.
11. Remove four motor bolts and remove bracket from motor.
12. Remove seal seat from bracket. Use wooden or plastic dowel to tamp the seat from the bracket.

REASSEMBLY

1. Clean seat cavity of the bracket thoroughly.
2. Thoroughly clean pump shaft. Assure that the shaft is not grooved and that there is no evidence of pitting or fretting. Polish the shaft with extra fine emery cloth and clean the keyway. If the shaft is grooved, fretted or worn, replace it.
3. Install the pump shaft onto the motor shaft, aligning set screws of the pump shaft with the keyway of the motor shaft. Ensure all debris and burrs are removed from the motor shaft and that the slinger is in place.
4. **For Type 21, 8, 9 seals:** Place the bracket on a firm surface with the seat cavity (pump end) up. Then place a small amount of vegetable oil on the seat cup or "O" ring seat. Place the seat in the seat cavity with the polished face up toward the pump end. Evenly push seat into cavity with fingers then gently tap seat into place with a wooden dowel or plastic rod (1-1/8" outside diameter). To help ensure the seat is not damaged place the cardboard disk supplied with the seal over the seat face.
5. Place bracket on motor (aligning the base if applicable). Secure bracket with four motor bolts.

6. Pull out pump shaft as far as it will go toward volute end and slightly snug one set screw to hold shaft in place.
7. Install seal head assembly

For Type 21 Seals:

- a. Lubricate shaft and elastomer with vegetable oil.
- b. Install rotary seal head onto pump shaft and slide toward seat until carbon face touches seal seat.
- c. Install seal spring and seal retainer.
- d. Install impeller. Slide impeller onto shaft until impeller hub bottoms out on the shoulder of the shaft. Note: ensure that the spring retainer does not slip between the shoulder of the shaft and the hub of the impeller. Tighten impeller setscrews securely.
8. Install new volute O-ring and mount volute. Secure with bolts and tighten.
9. Loosen shaft setscrew and install setting plate.

Note: For 1 stage pumps install the suction plate at this time.

10. Set impeller. Pull impeller until it comes in contact with the setting plate. Tighten shaft setscrews.
11. Remove setting plate. Install stage separator, diffuser and second impeller.
12. Install setting plate and set second impeller. Pull impeller until it comes in contact with the setting plate and tighten impeller setscrews.
13. Remove setting plate and repeat steps 11 & 12 for additional stages.
14. After last impeller is set remove setting plate and install suction plate.
15. Set impeller clearance with setting tool. Turn setting tool approximately 1/2-3/4 of a turn. Proceed to step 25.

16. For Type 8 & 9 Seals:

- a. Do not remove metal clips from seal head. Install seal head onto pump shaft sliding gently past shoulder of shaft.

- b. Remove clips from seal head assembly and discard. **Do not** tighten seal set screws at this time.
 - c. Slide seal head toward seat until carbon face touches seal seat.
 - d. Install impeller. Slide impeller onto shaft until impeller hub bottoms out on the shoulder of the shaft. Snug impeller setscrews.
17. Install new volute O-ring and mount volute. Secure with bolts and tighten.
 18. Loosen shaft setscrew and install setting plate.
 19. Set impeller. Pull impeller until it comes in contact with the setting plate. Tighten shaft setscrews.
 20. Remove setting plate and impeller.
 21. Set seal tension: Compress seal head against stationary seat until disk inside seal head lines up with scribed line around seal head. See diagram.
 22. Using short arm Allen wrench, tighten seal head set screws to pump shaft.

23. Install stage separator, diffuser and second impeller. Pull impeller until it comes in contact with the setting plate and tighten impeller setscrews.
24. Remove setting plate and repeat steps 11 through 14 for additional stages.
25. Rotate pump shaft by hand to make sure impeller does not rub against volute.
26. Return pump to installation, reconnect electric connections.
27. Start pump momentarily to observe shaft rotation. If rotation corresponds the rotation arrow pump may be put into service. If rotation is incorrect, switch any two leads on 3-phase motors. Check wiring diagram of motor for single phase rotation.
28. Remove top pipe plug (if applicable) from the front of volute and prime pump thoroughly, making sure all air is purged.
29. Start pump allowing adequate time to purge all air from system. Observe any gauges, flow meters, etc. to see if pump performs properly.

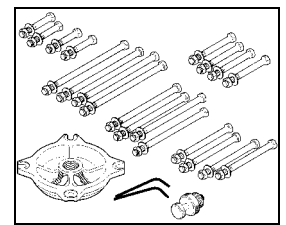
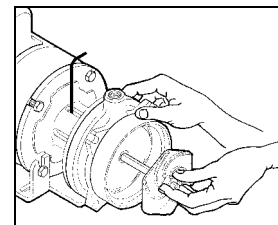
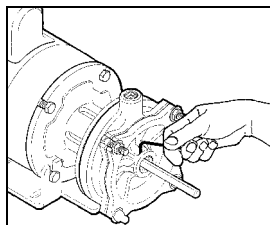
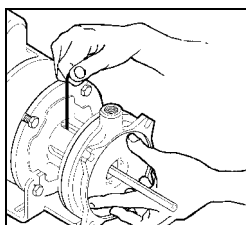
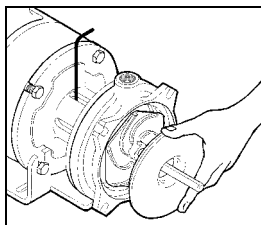



PRICE PUMP CO.

MS50SS PARTS LIST

Effective: January 1, 1993

Page 1 of 2

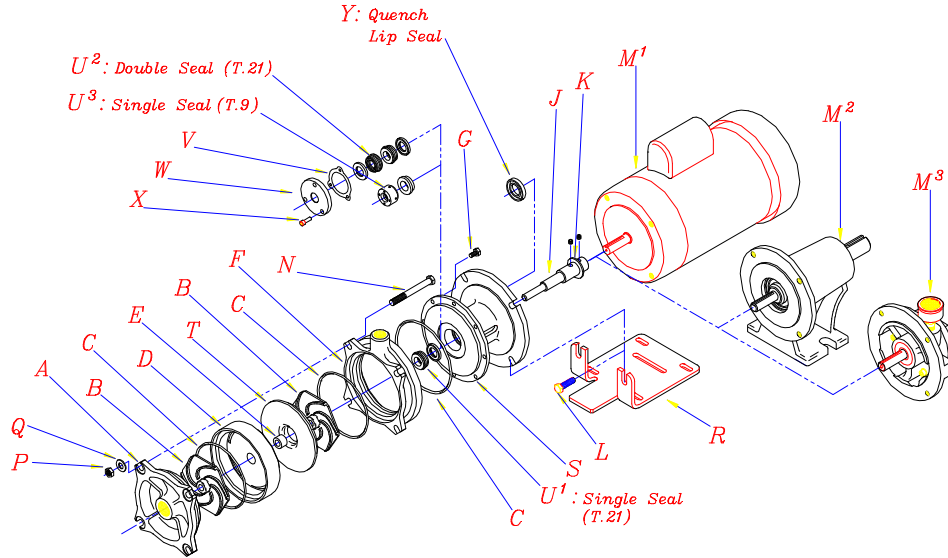
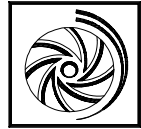

GF Teflon® = Glass Filled Teflon®

PART DESCRIPTION	1MS	2MS	3MS	4MS	5MS	6MS
A. Suction Plate	3010	3010	3010	3010	3010	3010
B. Impeller(s) (1 rqd per stage)	3040-4.12	3040-4.12	3040-4.12	3040-4.12	3040-4.12	3040-4.12
Impeller Setscrews (not shown-2 rqd per stage)	3080 (2 rqd)	3080 (4 rqd)	3080 (6 rqd)	3080 (8 rqd)	3080 (10 rqd)	3080 (12 rqd)
C. 'O' Rings(Diffuser/Volute)						
Viton® (std)	3070 (2 rqd)	3070 (3 rqd)	3070 (4 rqd)	3070 (5 rqd)	3070 (6 rqd)	3070 (7 rqd)
Teflon®	3071 (2 rqd)	3071 (3 rqd)	3071 (4 rqd)	3071 (5 rqd)	3071 (6 rqd)	3071 (7 rqd)
Neoprene	3072 (2 rqd)	3072 (3 rqd)	3072 (4 rqd)	3072 (5 rqd)	3072 (6 rqd)	3072 (7 rqd)
EPR	3073 (2 rqd)	3073 (3 rqd)	3073 (4 rqd)	3073 (5 rqd)	3073 (6 rqd)	3073 (7 rqd)
D. Diffuser(s)	N/A	3020-1 (1 rqd)	3020-1 (2 rqd)	3020-1 (3 rqd)	3020-1 (4 rqd)	3020-1 (5 rqd)
E. Bushing(s):						
Graphitar	N/A	3075 (1 rqd)	3075 (2 rqd)	3075 (3 rqd)	3075 (4 rqd)	3075 (5 rqd)
GF Teflon®	N/A	3076 (1 rqd)	3076 (2 rqd)	3076 (3 rqd)	3076 (4 rqd)	3076 (5 rqd)
F. Volute	3000	3000	3000	3000	3000	3000
G. Volute Bolts (8 rqd)	0917	0917	0917	0917	0917	0917
J. Shaft w/setscrews:						
5/8" ID	3050-1	3055-1	3060-1	3065-1	3066-1	3067-1
7/8" ID	3132-1	3133-1	3134-1	3135-1	3136-1	3137-1
K. Slinger, 7/8"	0522	0522	0522	0522	0522	0522
L. Motor Bolts (2 ea of ea rqd)	0673 & 0593	0673 & 0593	0673 & 0593	0673 & 0593	0673 & 0593	0673 & 0593
M1. Motor - Specify P/N						
M2. Power Frame 5/8" ID Shaft	5478	5478	5478	5478	5478	5478
Power Frame 7/8" ID Shaft	5501	5501	5501	5501	5501	5501
M3. Air Motor - Specify P/N						

Continued

MS50SS PARTS LIST
Effective: January 1, 1993

Continued

Part Description	1MS	2MS	3MS	4MS	5MS	6MS
N. Stage Bolts (4 rqd)	3083	3084	3085	3086	3087	3088
P. Stage Nuts (4 rqd)	3082	3082	3082	3082	3082	3082
Q. Washers (4 rqd)	3081	3081	3081	3081	3081	3081
R. Base	0199	0199	0199	0199	0199	0199
S. Bracket	0972	0972	0972	0972	0972	0972
T. Stage separator(s):						
Single Seal	none	3030 (1 rqd)	3030 (2 rqd)	3030 (3 rqd)	3030 (4 rqd)	3030 (5 rqd)
Double Seal	none	3030-1 (1 rqd)	3030 (1 rqd) & 3030-1 (1 rqd)	3030 (2 rqd) & 3030-1 (1 rqd)	3030 (3 rqd) & 3030-1 (1 rqd)	3030(4 rqd)& 3030-1 (1 rqd)
Suction Plate for Double Seal	3010-1	N/A	N/A	N/A	N/A	N/A
Seal w/Seat:						
U1. T.21 Viton® Single Seal	0553	0553	0553	0553	0553	0553
U2. T.21 Viton® Double Seal (2 rqd)	0985	0985	0985	0985	0985	0985
U3. T.9 Teflon® Single Seal	1150	1150	1150	1150	1150	1150
W. Double Seal Cover	0973	0973	0973	0973	0973	0973
V. Seal Cover Gasket	0974	0974	0974	0974	0974	0974
X. Seal Cover Bolts (3 rqd)	0256	0256	0256	0256	0256	0256
Y. Quench Lip Seal Viton®	0891	0891	0891	0891	0891	0891

Part #	MS50SS Repair Parts Kits	
3101	1 Stage	Impeller setscrews (2 ea) - shaft w/ SS - Slinger
3102	2 Stage	Stage Bushing (1 ea), Imp. setscrews (4 ea), Shaft w/setscrews, Slinger
3103	3 Stage	Stage Bushing (2 ea), Imp. setscrews (6 ea), Shaft w/setscrews, Slinger
3104	4 Stage	Stage Bushing (3 ea), Imp. setscrews (8 ea), Shaft w/setscrews, Slinger
3105	5 Stage	Stage Bushing (4 ea), Imp. setscrews (10 ea), Shaft w/setscrews, Slinger
3106	6 Stage	Stage Bushing (5 ea), Imp. setscrews (12 ea), Shaft w/setscrews, Slinger
	Note:	'O' rings must be ordered separately; 1 per stage plus one
		Viton® (std) P/N 3070
		Teflon® P/N 3071
		Neoprene P/N 3072
		EPR P/N 3073
	Note:	Seal/seats must be ordered in addition to repair kits by P/N.
		5/8" T.21 Viton® std. Optional T.9 single & T21 single or double seal elastomers available.
		T.9 Double Not Available



1. GENERAL

A. Seller's price is based on these sales terms and (i) this document together with any additional writings signed by Seller shall represent the final, complete and exclusive statement of the agreement between the parties and may not be modified, supplemented, explained or waived by parol evidence, Buyer's purchase order, a course of dealing, Seller's performance or delivery, or in any other way except in writing signed by an authorized representative of Seller, and (ii) these terms are intended to cover all activity of Seller and Buyer hereunder, including sales and use of products, parts and work and all related matters (references to products include parts and references to work include construction, installation and start-up). Any reference by Seller to Buyer's specifications and similar requirements are only to describe the products and work covered hereby and no warranties or other terms therein shall have any force of effect. Catalogs, circulars and similar pamphlets of the Seller are issued for general information purposes only and shall not be deemed to modify the provisions hereof.

B. The agreement formed hereby and the language herein shall be construed and enforced under the Uniform Commercial Code as in effect in the State of California on the date hereof.

2. TAXES

Any sales, use or other similar type taxes imposed on this sale or on this transaction are not included in the price. Such taxes shall be billed separately to the Buyer. Seller will accept a valid exemption certificate from the Buyer if applicable; however, if an exemption certificate previously accepted is not recognized by the governmental taxing authority involved and the Seller is required to pay the tax covered by such exemption certificate. Buyer agrees to promptly reimburse Seller for the taxes paid.

3. PERFORMANCE, INSPECTION AND ACCEPTANCE

A. Unless Seller specifically assumes installation, construction or start-up responsibility, all products shall be finally inspected and accepted within thirty (30) days after arrival at point of delivery. Products not covered by the foregoing and all work shall be finally inspected and accepted with thirty (30) days after completion of the applicable work by Seller. All claims whatsoever by Buyer (including claims for shortages) excepting only those provided for under the WARRANTY AND LIMITATION OF LIABILITY and PATENTS Clauses hereof must be asserted in writing by Buyer within said thirty (30) day period or they are waived. If this contract involves partial performance, all such claims must be asserted within said thirty (30) day period for each partial performance. There shall be no revocation of acceptance. Rejection may be only for defects substantially impairing the value of products or work and Buyer's remedy for lesser defects shall be those provided for under the WARRANTY AND LIMITATION OF LIABILITY Clause.

B. Seller shall not be responsible for non-performance or for delays in performance occasioned by any causes beyond Seller's reasonable control, including, but not limited to, labor difficulties, delays of vendors or carriers, fires, governmental actions, or shortages of material, components, labor, or manufacturing facilities. Any delays so occasioned shall affect a corresponding extension of Seller's performance dates which are, in any event, understood to be approximate. In no event shall Buyer be entitled to incidental or consequential

damages for late performance or for a failure to perform. Seller reserves the right to make partial shipments and to ship products, parts or work which may be completed prior to the scheduled performance date.

C. In the event that Seller has agreed to mount motors, turbines, gears, or other products which are not manufactured by Seller and which are not an integral part of Seller's manufactured product, and a delay in the delivery of such products to Seller occurs that will cause a delay in Seller's performance date, Seller reserves the right to ship its product upon completion of manufacture and to refund an equitable portion of the amount originally included in the purchase price for mounting without incurring liability for non-performance.

D. Seller reserves to itself the right to change its specifications, drawings and standards if such changes will not impair the performance of its products, and parts, and further that such products, and parts, will meet any of Buyer's specifications and other specific product requirements which are a part of this agreement.

E. The manufacture and inspection of products and parts shall be to Seller's Engineering and Quality Assurance standards plus such other inspections, tests of documentation as are specifically agreed to by Seller. Requirements for any additional inspection, tests, documentation, or Buyer witness of manufacture, test, and/or inspection shall be subject to additional charges.

4. TITLE AND RISK OF LOSS

Title and risk of loss shall pass to buyer upon delivery of products at the designated Ex Works place (Incoterms 1990) unless other wise agreed by the parties.

5. EROSION AND CORROSION

It is specifically understood that products and parts sold hereunder are not warranted for operation with erosive or corrosive fluids. No product or part shall be deemed to be defective by reason of failure to resist erosive or corrosive action of any fluid and Buyer shall have no claim whatsoever against Seller therefore.

6. WARRANTY AND LIMITATION OF LIABILITY.

A. Seller warrants only that its product and parts, when shipped, and its work (including installation, construction and start-up), when performed will meet all applicable specifications and other specific product and work requirements (including those of performance), if any, of this agreement, and will be free from defects in materials and workmanship. With respect to products, parts and work not manufactured or performed by Seller, Seller's only obligation shall be to assign to Buyer, to the extent possible, whatever warranty Seller requires from the manufacturer. All claims for defective products or parts under this warranty must be made in writing immediately upon discovery and, in any event, within one (1) year after initial start-up or eighteen (18) months after shipment, whichever first occurs, and all claims for defective work must be made in writing immediately upon discovery and in any event, within one (1) year of completion thereof by Seller. Defective items must be held for Seller's inspection and returned to the original f.o.b. point upon request. THE FOREGOING IS EXPRESSLY IN LIEU OF ALL OTHER WARRANTIES WHATSOEVER, EXPRESS, IMPLIED AND STATUTORY, INCLUDING WITHOUT LIMITATION, THE IMPLIED, WARRANTIES OF MERCHANTABILITY AND FITNESS.

B. Upon Buyer's submission of a claim as provided above and its substantiation, Seller shall at its option either (i) repair or replace its product, part or work at the original place of delivery, or (ii) refund an equitable portion of the purchase price.

C. THE FOREGOING IS SELLER'S ONLY OBLIGATION AND BUYER'S EXCLUSIVE REMEDY FOR BREACH OF WARRANTY AND, EXCEPT FOR GROSS NEGLIGENCE, WILLFUL MISCONDUCT, AND REMEDIES PERMITTED UNDER THE PERFORMANCE, INSPECTION AND ACCEPTANCE AND THE PATENTS CLAUSES HEREOF, THE FOREGOING IS BUYER EXCLUSIVE REMEDY AGAINST SELLER FOR ALL CLAIMS ARISING HEREUNDER OR RELATING HERETO WHETHER SUCH CLAIMS ARE BASED ON BREACH OF CONTRACT, TORT (INCLUDING NEGLIGENCE) OR OTHER THEORIES. BUYER'S FAILURE TO SUBMIT A CLAIM AS PROVIDED ABOVE SHALL SPECIFICALLY WAIVE ALL CLAIMS FOR DAMAGES OR OTHER RELIEF, INCLUDING BUT NOT LIMITED TO CLAIMS BASED ON LATENT DEFECTS. IN NO EVENT SHALL BUYER BE ENTITLED TO INDIRECT, SPECIAL, INCIDENTAL OR CONSEQUENTIAL DAMAGES, NOR FOR DAMAGES FOR LOSS OF USE, LOST PROFITS OR REVENUE, INTEREST, LOST GOODWILL, WORK OR PRODUCTION STOPPAGE, IMPAIRMENT OF OTHER GOODS, INCREASED EXPENSES OF OPERATION, OR THE COST OF PURCHASING REPLACEMENT POWER OR OTHER SERVICES BECAUSE OF SERVICE INTERRUPTIONS. FURTHERMORE, IN NO EVENT SHALL SELLER'S TOTAL LIABILITY FOR DAMAGES OF BUYER EXCEED THE PURCHASE PRICE OF THE PRODUCTS OR PARTS MANUFACTURED BY SELLER AND UPON WHICH SUCH LIABILITY IS BASED. ANY ACTION ARISING HERE-UNDER OR RELATED HERETO, WHETHER BASED ON BREACH OF CONTRACT, TORT (INCLUDING NEGLIGENCE) OR OTHER THEORIES, MUST BE COMMENCED WITHIN ONE (1) YEAR AFTER THE CAUSE OF ACTION ACCRUES OR IT SHALL BE BARRED.

7. PATENTS

Seller agrees to assume the defense of any suit for infringement of any patents brought against Buyer to the extent of such suit charges infringement of an apparatus or product claim by Seller's product in an of itself, provided (i) said product is built entirely to Seller's design, (ii) Buyer notifies Seller in writing of the filing of such suit within ten (10) days after the service of process thereof, and (iii) Seller is given complete control of the defense of such suit, including the right to defend, settle and make changes in the product for the purpose of avoiding infringement of any process or method claims, unless infringement of such claims is the result of following specific instruction furnished by Seller.

8. EXTENT OF SUPPLY

Only products and listed in Seller's proposal are included in this agreement. It must not be assumed that Seller has included anything beyond same.

9. MANUFACTURING SOURCES

To maintain delivery schedules, Seller reserves the right to have all or any part of the Buyer's order manufactured at any of Seller's or its licensee's plants on a world-wide basis.

(Terms3-93Bob)