

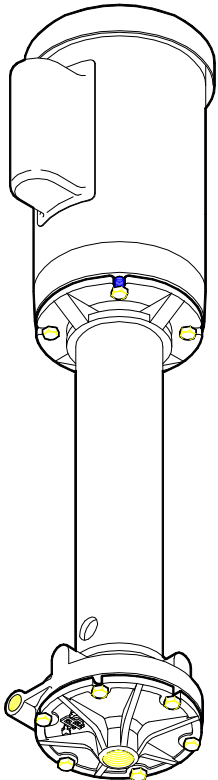

PRICE® PUMP Installation, Operating, and Maintenance Manual

Type LT Vertical

Caution:
Before installing,
repairing or performing
maintenance on this
pump, read these
instructions completely.



Installation

Electrical

WARNING!

Ground motor before connecting to electrical power supply! Failure to ground motor can cause severe or fatal electrical shock hazard!

Do not ground to gas supply line!

Disconnect power to motor before working on motor or pump!

Match voltage to nameplate voltage on motor. Incorrect voltage can cause fire or seriously damage motor, voiding warranty.

Vertical Close Coupled Motor Pumps

Special Mounting Requirements

Vertical pumps must use the Price Pump Company vertical mounting plate to support column. The mounting plate must be securely bolted to a rigid surface.

Direction of Rotation

Note: Motor shaft rotation is viewed from the suction end of pump. A rotational arrow is shown on the front of the pump volute casing. Incorrect rotation can cause pump damage, failure or reduced performance, voiding warranty. It is best to check rotation by **momentarily** energizing or jogging the motor prior to filling pump with liquid.

Warning! Do not operate pump without liquid for more than a few seconds, as damage will result to bushing.

PLUMBING

All piping should be supported independently of the pump. Piping should not exert any stress on the pump connections.

Suction piping must be designed to prevent air from being trapped in high spots in the piping. This condition may cause the pump to vapor lock as the air bubble moves into the pump.

1. Discharge Piping.

For flow and discharge head control it is advisable to install a valve (globe, ball, or other adjustable and non-leak type) in the discharge line close to the pump. The valve may be closed during system repairs to prevent backflow. By installing a check valve in the discharge line backflow can also be prevented during maintenance or during periods of pump stoppage.

2. Vertical Pumps

Care must be taken when attaching piping to the discharge of vertically mounted pumps to avoid piping stress (axial or radial force) on the discharge port. Such force will push the pump out of vertical alignment, causing premature failure. **No piping stress can be allowed against the discharge connection.**

Vertically mounted pumps must have impeller submerged at start-up. Also, inlet of pump must be submerged far enough to prevent vortexing and the resulting entrance of air into the pump. Where conditions limit how far pump can be submerged tank baffles should be used to prevent vortex formation. The use of a standpipe (vertical pipe connected to pump suction) will allow liquid to be drawn down below level of the impeller during operation. Note, however, that pump must be submerged during start-up in order to gain prime.

OPERATION

Priming. All centrifugal pumps must be filled with liquid prior to start up. For the pump illustrated in this manual completely fill the volute and suction lines prior to operation. It is suggested that during initial start up the discharge valve be closed and then opened as the motor develops full rpm's. If pump does not build up pressure as motor speed increases, shut down and reprime pump. Make sure that liquid flow into pump is not restricted (see "Troubleshooting").

Note: A centrifugal pump's flow and head (pressure) will vary with the amount of resistance (friction and flow restrictions) in the discharge line. As a valve on the discharge line opens the flow and motor amp draw will increase and head will drop. As a valve on the discharge is closed the flow and amp draw will decrease and the head will increase. If resistance in the discharge line is not sufficient the pump will operate at a condition of maximum (or "choked") flow, also sometimes called "end of performance curve."

Maximum horsepower is required to operate at this point and motor overload may result. If excessive amp draw and motor overload is recurring, reduce the system flow by installing a valve on the discharge line and restricting flow.

Alternatively, reduce pump head by trimming impeller to a smaller diameter. Consult local Price Pump dealer for assistance.

CAUTION

Disconnect power to pump before servicing to avoid dangerous or fatal electrical shock hazards.

If pump has been used to pump hazardous materials be certain that all materials have been removed prior to working on the pump.

Inverting pump with liquid in it could cause liquid to get into motor bearings and cause damage. Before disassembling be certain all liquid is removed from the pump.

TROUBLESHOOTING

1. Pump fails to build pressure:

Check for:

- a. Pump not primed.
- b. Incorrect rotation.
- c. Driver speed too low.
- d. Suction line restricted.
- e. Driver failure.
- f. Plugged or damaged impeller.
- g. Pump or impeller undersized.
- h. Pump cavitation.
- i. Impeller rubbing volute.

2. Pump fails to provide enough flow.

Check for:

- a. System resistance too high.
- b. Pump undersized.
- c. Pump not primed.
- d. Driver speed too low.
- e. Poor suction conditions
- f. Impeller rubbing volute due to improper installation.
- g. Pump cavitation.
- h. Plugged or damaged impeller.

3. Excessive noise or vibration during operation.

Check for:

- a. Motor bearing failing.
- b. Pump cavitating.
- c. Impeller rubbing volute.
- d. Shaft alignment.
- e. Pump bushing worn.

4. Pump gradually loses pressure and head.

Check for:

- a. Increasing temperature causing cavitation or liquid vaporization.
- b. Driver failure.
- c. Suction lift too high.
- d. Air entering suction line.

5. Motor/pump overheating.

Check for:

- a. Excessive flow and amp draw. (Throttle discharge)
- b. Low voltage or frequency.
- c. Flow too low with resulting heat rise.
- d. Bearing failure.
- e. System temperature too high.

Before attempting any repairs under warranty, contact Distributor to obtain factory authorization. Repairs carried out without authorization may void warranty. Many causes of pump system failure are due to improper system design. Refer to the Trouble Shooting List in this manual before carrying out pump inspection.

CCW = Counter Clockwise

CW = Clockwise

DISASSEMBLY

1. Disconnect power source to motor.
2. Disconnect electrical connections tagging wires carefully to preserve correct rotation. Loosen motor base.
3. Remove pump and motor assembly to repair area. Observe position of all parts prior to disassembly.
4. Remove bolts and remove volute cover from pump.
5. Remove impeller locknut and impeller. Unscrew CCW. A small pair of c-clamp vise grips may be clamped to the pump shaft to prevent rotation while unscrewing impeller locknut. Avoid damaging the set screws of the shaft with the vise grips.
7. Remove four motor bolts and remove column from motor.
8. Loosen setscrews in pump shaft and remove shaft from motor. **Note:** New setscrews must be used when shaft is reinstalled.
9. Remove allen cap bolts in bushing plate assembly and remove bushing plate assembly. **Note:** New bushing should be used when rebuilding pump.

REASSEMBLY

1. Clean pump and motor shaft thoroughly.
2. Assure that the shaft is not grooved and that there is no evidence of pitting or fretting where the bushing rides. If the shaft is grooved, fretted or worn, replace it.
3. Install the pump shaft onto the motor shaft. Ensure all debris and burrs are removed from the motor shaft.
4. Install bushing and plate into column. Tighten three allen cap screws securely (**Note:** Non-galling thread compound must be used on the allen cap bolts).
5. Install column onto motor being careful not to damage bushing.
6. Install motor bolts and tighten.
7. Install impeller and impeller locknut. Ensure shoulder of shaft is protruding above bushing before installing impeller.
 - a. Screw impeller onto pump shaft CW. Hold pump shaft with c-clamp vise grips and thread locknut on CW until snug. **Note:** Serviceable loctite

- must be used on the impeller locknut.
8. Install new volute gasket and mount volute cover. Secure with bolts and tighten evenly.
 9. Set impeller clearance. Slide pump shaft towards volute cover until impeller touches volute cover. Back the impeller and shaft away from the volute cover approximately .020" and tighten both pump shaft setscrews at this time. **Note:** Ensure both setscrews are securely tightened.
 10. Invert pump and rotate pump shaft by hand to ensure impeller does not rub against volute cover.
 11. Return pump to installation, reconnect electric connections.
 12. Start pump momentarily to observe shaft rotation. If rotation corresponds to the rotation arrow, pump may be put into service. If rotation is incorrect, switch any two leads on 3-phase motors. Check wiring diagram of motor for single phase rotation.
 13. Start pump allowing adequate time to purge all air from system. Observe any gauges, flow meters, etc., to see if pump performs properly.



PRICE PUMP CO.

LT25V PARTS LIST

Effective: July 1, 1992

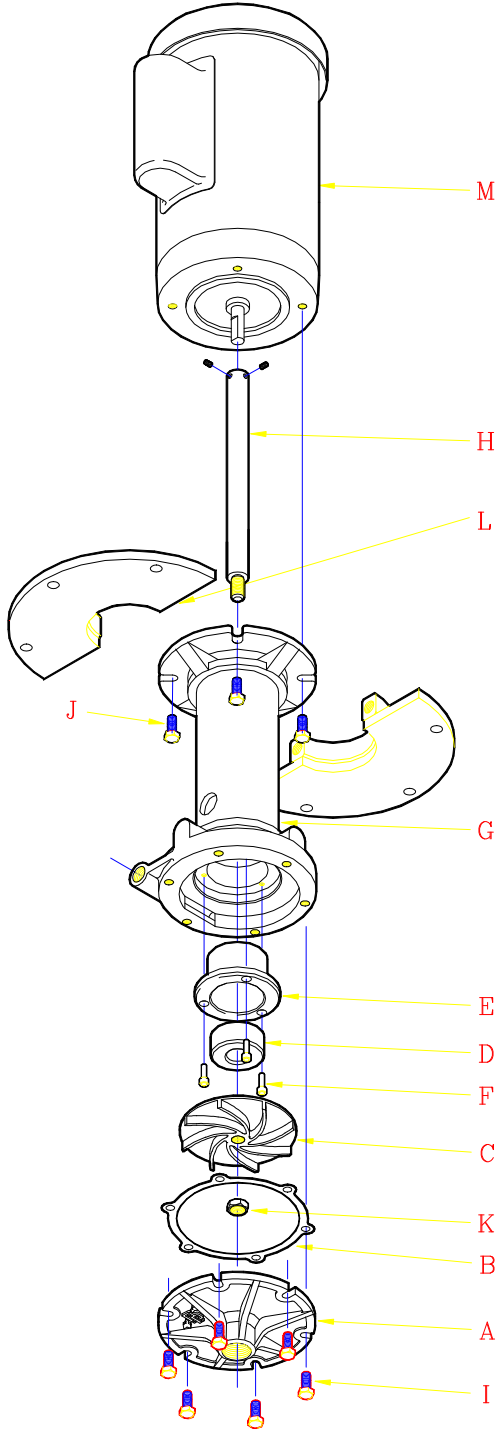

| | | |
|----|--|-----------|
| A. | Volute Cover | 0313 |
| B. | Gasket | 0318 |
| C. | Impeller | 0315-3.34 |
| D. | Bushing: | |
| | Graphitar (Std) | 0672 |
| | Flurogold (Opt) | 0691 |
| E. | Bushing Plate | 0747 |
| F. | Lockscrew (3 Rqd) | 0256 |
| G. | Column Assembly: | |
| | 7 1/2" | 0453 |
| | 13" | 0454 |
| | 20" | 0455 |
| H. | Shaft w/ Setscrews: | |
| | 7 1/2" | 0316-3 |
| | 13" | 0316-5 |
| | 20" | 0316-7 |
| I. | Volute Bolts (6 rqd) | 0917 |
| J. | Motor Bolts (4 rqd) | 0376 |
| K. | Impeller Locknut | 0897 |
| L. | Mounting Plate (Opt) | |
| | Steel | |
| | Stainless Steel | |
| M. | Motors: | |
| | 1/8HP,1800, 1/60/115/230, TEFC | 1608 |
| | 1/3HP, 3600, 1/60/115/230, DP | 1438 |
| | 1/3HP, 3600, /50/60/100/200/115/230, TEFC | 1439 |
| | 1/3HP, 3600, 3/50/60/220/440/230/460, TEFC | 1440 |
| | 1/3HP, 3600, 1/50/60/115/230, X-P | 1441 |
| | 1/3HP, 3600, 3/50/60/220/440/230/460, X-P | 1442 |



PRICE PUMP CO.

**LT25 VERTICAL
OUTLINE DRAWING**
Effective: January 1, 1993

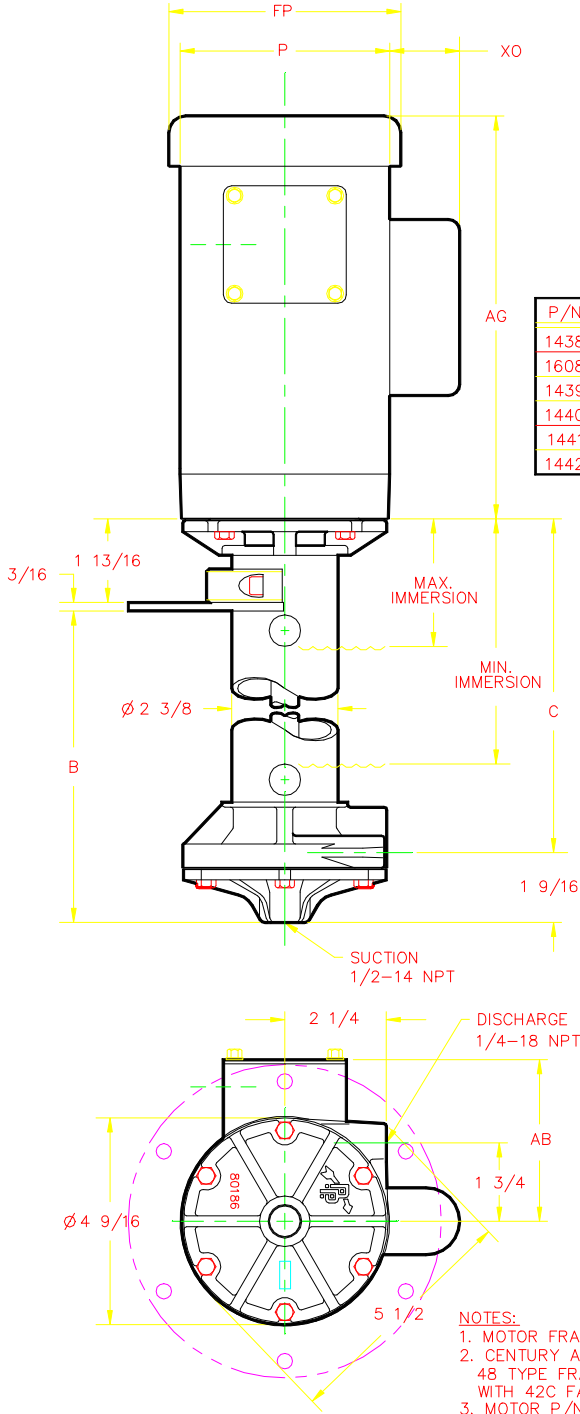

MOTOR FRAME DIMENSIONS

| P/N | TYPE | PH | MFR | P | AB | AG | FP | XO |
|------|------|------|---------|---------|--------|--------|--------|--------|
| 1438 | ODP | 1/60 | CENTURY | 5 5/8 | N/A | 8 | N/A | 2 |
| 1608 | | 1/60 | | | | 8 | | |
| 1439 | TEFC | 1/60 | BALDOR | 4 11/16 | 4 1/16 | 9 5/16 | 5 3/16 | 1 9/16 |
| 1440 | | 3/60 | | | | | | N/A |
| 1441 | EXP | 1/60 | G.E. | 6 5/8 | N/A | 9 5/8 | N/A | N/A |
| 1442 | | 3/60 | | | | 9 1/4 | | |

| COLUMN LENGTH | COLUMN DIMS | | IMMERSIONS | |
|---------------|-------------|-------|------------|--------|
| | B | C | MAX | MIN |
| 7 1/2 | 7 1/16 | 7 1/2 | | 5" |
| 13" | 12 9/16 | 13" | 2 7/8 | 10 1/2 |
| 20" | 19 9/16 | 20" | | 17 1/2 |

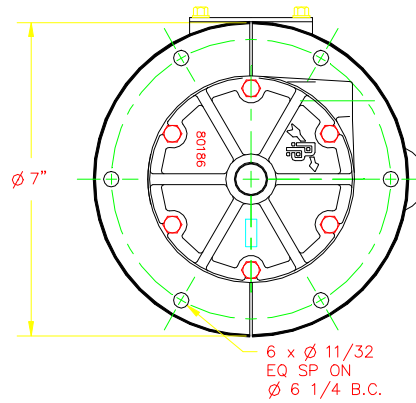

MOUNTING PLATE DETAIL

- NOTES:
1. MOTOR FRAMES WILL VARY IN LOOK, PER MANUFACTURER.
 2. CENTURY AND G.E. MOTORS ARE MANUFACTURED WITH 48 TYPE FRAME AND 42C FACE, BALDOR IS 42 TYPE FRAME WITH 42C FACE.
 3. MOTOR P/N INDICATES PRICE PUMP CO. PART NUMBER, AND HAS NO SIMILARITY WITH MANUFACTURER PART NUMBERS.
 4. ALL DIMENSIONS HAVE BEEN ROUNDED TO THE NEAREST 1/16 OF AN INCH.



GENERAL TERMS OF SALE FOR PRODUCTS

Effective: January 1, 1993

1. GENERAL

A. Seller's price is based on these sales terms and (i) this document together with any additional writings signed by Seller shall represent the final, complete and exclusive statement of the agreement between the parties and may not be modified, supplemented, explained or waived by parol evidence, Buyer's purchase order, a course of dealing, Seller's performance or delivery, or in any other way except in writing signed by an authorized representative of Seller, and (ii) these terms are intended to cover all activity of Seller and Buyer hereunder, including sales and use of products, parts and work and all related matters (references to products include parts and references to work include construction, installation and start-up). Any reference by Seller to Buyer's specifications and similar requirements are only to describe the products and work covered hereby and no warranties or other terms therein shall have any force of effect. Catalogs, circulars and similar pamphlets of the Seller are issued for general information purposes only and shall not be deemed to modify the provisions hereof.

B. The agreement formed hereby and the language herein shall be construed and enforced under the Uniform Commercial Code as in effect in the State of California on the date hereof.

2. TAXES

Any sales, use or other similar type taxes imposed on this sale or on this transaction are not included in the price. Such taxes shall be billed separately to the Buyer. Seller will accept a valid exemption certificate from the Buyer if applicable; however, if an exemption certificate previously accepted is not recognized by the governmental taxing authority involved and the Seller is required to pay the tax covered by such exemption certificate. Buyer agrees to promptly reimburse Seller for the taxes paid.

3. PERFORMANCE, INSPECTION AND ACCEPTANCE

A. Unless Seller specifically assumes installation, construction or start-up responsibility, all products shall be finally inspected and accepted within thirty (30) days after arrival at point of delivery. Products not covered by the foregoing and all work shall be finally inspected and accepted with thirty (30) days after completion of the applicable work by Seller. All claims whatsoever by Buyer (including claims for shortages) excepting only those provided for under the WARRANTY AND LIMITATION OF LIABILITY AND PATENTS Clauses hereof must be asserted in writing by Buyer within said thirty (30) day period or they are waived. If this contract involves partial performance, all such claims must be asserted within said thirty (30) day period for each partial performance. There shall be no revocation of acceptance. Rejection may be only for defects substantially impairing the value of products or work and Buyer's remedy for lesser defects shall be those provided for under the WARRANTY AND LIMITATION OF LIABILITY Clause.

B. Seller shall not be responsible for non-performance or for delays in performance occasioned by any causes beyond Seller's reasonable control, including, but not limited to, labor difficulties, delays of vendors or carriers, fires, governmental actions, or shortages of material, components, labor, or manufacturing facilities. Any delays so occasioned shall affect a corresponding extension of Seller's performance dates which are, in any event, understood to be approximate. In no event shall Buyer be entitled to incidental or consequential damages for late performance or for a failure to perform. Seller reserves the right to make partial shipments and to ship products, parts or work which may be completed prior to the scheduled performance date.

C. In the event that Seller has agreed to mount motors, turbines, gears, or other products which are not manufactured by Seller and which are not an integral part of Seller's manufactured product, and a delay in the delivery of such products to Seller occurs that will cause a delay in Seller's performance date, Seller reserves the right to ship its product upon completion of manufacture and to refund an equitable portion of the amount originally included in the purchase price for mounting without incurring liability for non-performance.

D. Seller reserves to itself the right to change its specifications, drawings and standards if such changes will not impair the performance of its products, and parts, and further that such products, and parts, will meet any of Buyer's specifications and other specific product requirements which are a part of this agreement.

E. The manufacture and inspection of products and parts shall be to Seller's Engineering and Quality Assurance standards plus such other inspections, tests of documentation as are specifically agreed to by Seller. Requirements for any additional inspection, tests, documentation, or Buyer witness of manufacture, test, and/or inspection shall be subject to additional charges.

4. TITLE AND RISK OF LOSS

Title and risk of loss shall pass to buyer upon delivery of products at the designated Ex Works place (Incoterms 1990) unless other wise agreed by the parties.

5. EROSION AND CORROSION

It is specifically understood that products and parts sold hereunder are not warranted for operation with erosive or corrosive fluids. No product or part shall be deemed to be defective by reason of failure to resist erosive or corrosive action of any fluid and Buyer shall have no claim whatsoever against Seller therefore.

6. WARRANTY AND LIMITATION OF LIABILITY.

A. Seller warrants only that its product and parts, when shipped, and its work (including installation, construction and start-up), when performed will meet all applicable specifications and other specific product and work requirements (including those of performance), if any, of this agreement, and will be free from defects in materials and workmanship. With respect to products, parts and work not manufactured or performed by Seller, Seller's only obligation shall be to assign to Buyer, to the extent possible, whatever warranty Seller requires from the manufacturer. All claims for defective products or parts under this warranty must be made in writing immediately upon discovery and, in any event, within one (1) year after initial start-up or eighteen (18) months after shipment, whichever first occurs, and all claims for defective work must be made in writing immediately upon discovery and in any event, within one (1) year of completion thereof by Seller. Defective items must be held for Seller's inspection and returned to the original f.o.b. point upon request. THE FOREGOING IS EXPRESSLY IN LIEU OF ALL OTHER WARRANTIES WHATSOEVER, EXPRESS, IMPLIED AND STATUTORY, INCLUDING WITHOUT LIMITATION, THE IMPLIED WARRANTIES OF MERCHANTABILITY AND FITNESS.

B. Upon Buyer's submission of a claim as provided above and its substantiation, Seller shall at its option either (i) repair or replace its product, part or work at the original place of delivery, or (ii) refund an equitable portion of the purchase price.

C. THE FOREGOING IS SELLER'S ONLY OBLIGATION AND BUYER'S EXCLUSIVE REMEDY FOR BREACH OF WARRANTY AND, EXCEPT FOR GROSS NEGLIGENCE, WILLFUL MISCONDUCT, AND REMEDIES PERMITTED UNDER THE PERFORMANCE, INSPECTION AND ACCEPTANCE AND THE PATENTS CLAUSES HEREOF, THE FOREGOING IS BUYER EXCLUSIVE REMEDY AGAINST SELLER FOR ALL CLAIMS ARISING HEREUNDER OR RELATING HERETO WHETHER SUCH CLAIMS ARE BASED ON BREACH OF CONTRACT. TORT (INCLUDING NEGLIGENCE) OR OTHER THEORIES. BUYER'S FAILURE TO SUBMIT A CLAIM AS PROVIDED ABOVE SHALL SPECIFICALLY WAIVE ALL CLAIMS FOR DAMAGES OR OTHER RELIEF, INCLUDING BUT NOT LIMITED TO CLAIMS BASED ON LATENT DEFECTS. IN NO EVENT SHALL BUYER BE ENTITLED TO INDIRECT, SPECIAL, INCIDENTAL OR CONSEQUENTIAL DAMAGES, NOR FOR DAMAGES FOR LOSS OF USE, LOST PROFITS OR REVENUE, INTEREST, LOST GOODWILL, WORK OR PRODUCTION STOPPAGE, IMPAIRMENT OF OTHER GOODS, INCREASED EXPENSES OF OPERATION, OR THE COST OF PURCHASING REPLACEMENT POWER OR OTHER SERVICES BECAUSE OF SERVICE INTERRUPTIONS. FURTHERMORE, IN NO EVENT SHALL SELLER'S TOTAL LIABILITY FOR DAMAGES OF BUYER EXCEED THE PURCHASE PRICE OF THE PRODUCTS OR PARTS MANUFACTURED BY SELLER AND UPON WHICH SUCH LIABILITY IS BASED. ANY ACTION ARISING HERE-UNDER OR RELATED HERETO, WHETHER BASED ON BREACH OF CONTRACT, TORT (INCLUDING NEGLIGENCE) OR OTHER THEORIES, MUST BE COMMENCED WITHIN ONE (1) YEAR AFTER THE CAUSE OF ACTION ACCRUES OR IT SHALL BE BARRED.

7. PATENTS

Seller agrees to assume the defense of any suit for infringement of any patents brought against Buyer to the extent of such suit charges infringement of an apparatus or product claim by Seller's product in an of itself, provided (i) said product is built entirely to Seller's design, (ii) Buyer notifies Seller in writing of the filing of such suit within ten (10) days after the service of process thereof, and (iii) Seller is given complete control of the defense of such suit, including the right to defend, settle and make changes in the product for the purpose of avoiding infringement of any process or method claims, unless infringement of such claims is the result of following specific instruction furnished by Seller.

8. EXTENT OF SUPPLY

Only products and listed in Seller's proposal are included in this agreement. It must not be assumed that Seller has included anything beyond same.

9. MANUFACTURING SOURCES

To maintain delivery schedules, Seller reserves the right to have all or any part of the Buyer's order manufactured at any of Seller's or its licensee's plants on a world-wide basis.

(Terms3-/93Bob)

Thank You for Choosing Price Pumps

Visit our Web Site at

<http://www.PricePump.com>