

stationary version

PVXC series pumps are supplied complete with base pedestal elbow (with mating flange), pump slide bracket and guide tube top support, for fixed sewer installations.



RANGE OF PERFORMANCE

Flow rate up to 1200 l/min (72 m³/h)
Head up to 16 m

LIMITS OF USE

Depth up to 10 m
Liquid temperature up to + 40°C
Passage of solid bodies max Ø 50 mm for PVXC 15-20-30/50
Passage of solid bodies max Ø 70 mm for PVXC 15-20-30/70
For continuous duty: minimum immersion 430 mm from pump base

CONSTRUCTION AND SAFETY STANDARDS

EN 60034-1
IEC 34-1
CEI 2-3



INSTALLATION AND USE

PVXC SERIES PUMPS ARE MADE OF EXCEPTIONALLY ROBUST HEAVY GAUGE CAST IRON, RESISTANT TO ABRASION AND LONG LASTING, AND HAVE A VORTEX TYPE IMPELLER. THEY ARE SUITABLE FOR SEWAGE, WASTE WATER AND SLUDGE, INCLUDING WATER CONTAINING SOLIDS OR MUD. THEY ARE IDEAL FOR FIXED SEWAGE INSTALLATIONS, TUNNELS, UNDERGROUND CARPARKS, SUMPS AND SIMILAR APPLICATIONS.

GUARANTEE 2 YEARS subject to our general terms of sale.

CONSTRUCTION CHARACTERISTICS

- **PUMP BODY, MOTOR CASING AND BASE PEDESTAL:** cast iron.
- **IMPELLER:** cast iron.
- **BASE:** stainless steel AISI 304.
- **MOTOR SHAFT:** stainless steel EN 10088-3 - 1.4057.
- **DOUBLE SEAL:** mechanical seal silicon carbide - widia - NBR, with oil barrier chamber and inner lip seal to protect the seal in the event of dry running.
- **MOTOR:** submersible asynchronous, 2 pole, for continuous duty.
 - PVXCm:** single-phase 220÷240 V - 50 Hz
 - Models up to 1.5 kW have built in thermal protection
 - 2.2 kW single-phase versions have a thermal protector provided in the winding for connection to the control box.
 - PVXC:** three-phase 380÷415 V - 50 Hz.
 - Thermal protectors are provided in the winding for connection to the external control panel
- **INSULATION:** class F. ● **PROTECTION:** IP 68.

STANDARD FEATURES:

Base pedestal elbow (duct foot)
Threaded delivery counterflange
Top supports for guide tubes

- PVXCm** (single-phase) Float switch.
 - 10m** "H07 RN-F" submersible power cable with Schuko plug.
 - 1.1 to 1.5 kW models are supplied with control box with capacitor and manual reset motor protector.
 - 2.2 kW models are supplied with control box type QES 300 MONO.
- PVXC** (three-phase) **10m** "H07 RN-F" neoprene power cable

OPTIONS ON REQUEST

- ⇒ control box for three-phase pumps
- ⇒ dual voltage: 230/400 V or 400/690 V
- ⇒ single-phase versions without float switch
- ⇒ other voltages or frequency 60 Hz

CURVES AND PERFORMANCE DATA AT n= 2900 1/min

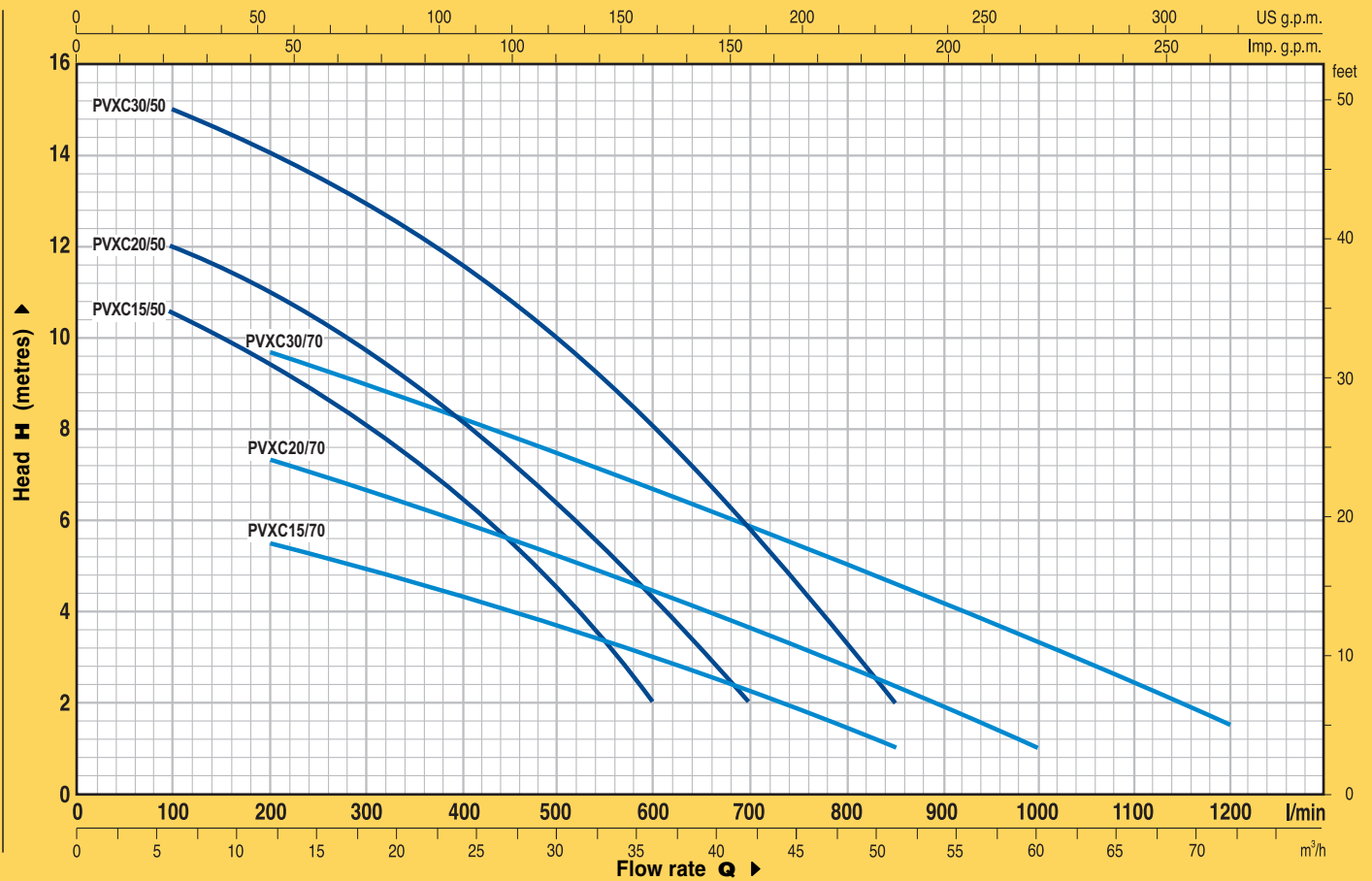

| TYPE | | POWER | | Q | H metres | | | | | | | | | | | | | | | | | | |
|--------------|-------------|-------|-----|----------|----------|------|-----|-----|------|------|------|-----|-----|-----|-----|-----|-----|------|------|------|----|--|--|
| Single-phase | Three-phase | kW | HP | | m³/h | 0 | 6 | 12 | 18 | 21 | 24 | 27 | 30 | 36 | 42 | 48 | 51 | 54 | 60 | 66 | 72 | | |
| | | | | l/min | 0 | 100 | 200 | 300 | 350 | 400 | 450 | 500 | 600 | 700 | 800 | 850 | 900 | 1000 | 1100 | 1200 | | | |
| PVXCm 15/50 | PVXC 15/50 | 1.1 | 1.5 | H metres | 11.5 | 10.5 | 9.5 | 8.2 | 7.2 | 6.5 | 5.6 | 4.5 | 2 | | | | | | | | | | |
| PVXCm 20/50 | PVXC 20/50 | 1.5 | 2 | | 13 | 12 | 11 | 9.5 | 9 | 8 | 7.2 | 6.5 | 4.5 | 2 | | | | | | | | | |
| PVXCm 30/50 | PVXC 30/50 | 2.2 | 3 | | 16 | 15 | 14 | 13 | 12.3 | 11.5 | 10.8 | 10 | 8 | 5.9 | 3.3 | 2 | | | | | | | |
| PVXCm 15/70 | PVXC 15/70 | 1.1 | 1.5 | | 6.5 | — | 5.5 | 5 | 4.7 | 4.4 | 4 | 3.7 | 3 | 2.2 | 1.5 | 1 | | | | | | | |
| PVXCm 20/70 | PVXC 20/70 | 1.5 | 2 | | 8.5 | — | 7.4 | 6.7 | 6.3 | 6 | 5.6 | 5.2 | 4.5 | 3.6 | 2.8 | 2.4 | 2 | 1 | | | | | |
| PVXCm 30/70 | PVXC 30/70 | 2.2 | 3 | | 11 | — | 9.7 | 9 | 8.6 | 8.2 | 7.8 | 7.5 | 6.7 | 5.8 | 5 | 4.6 | 4.2 | 3.3 | 2.5 | 1.5 | | | |

Q = Flow rate H = Total manometric head

Tolerance of the performance curves according to EN ISO 9906 App. A.

DIMENSIONS AND WEIGHTS

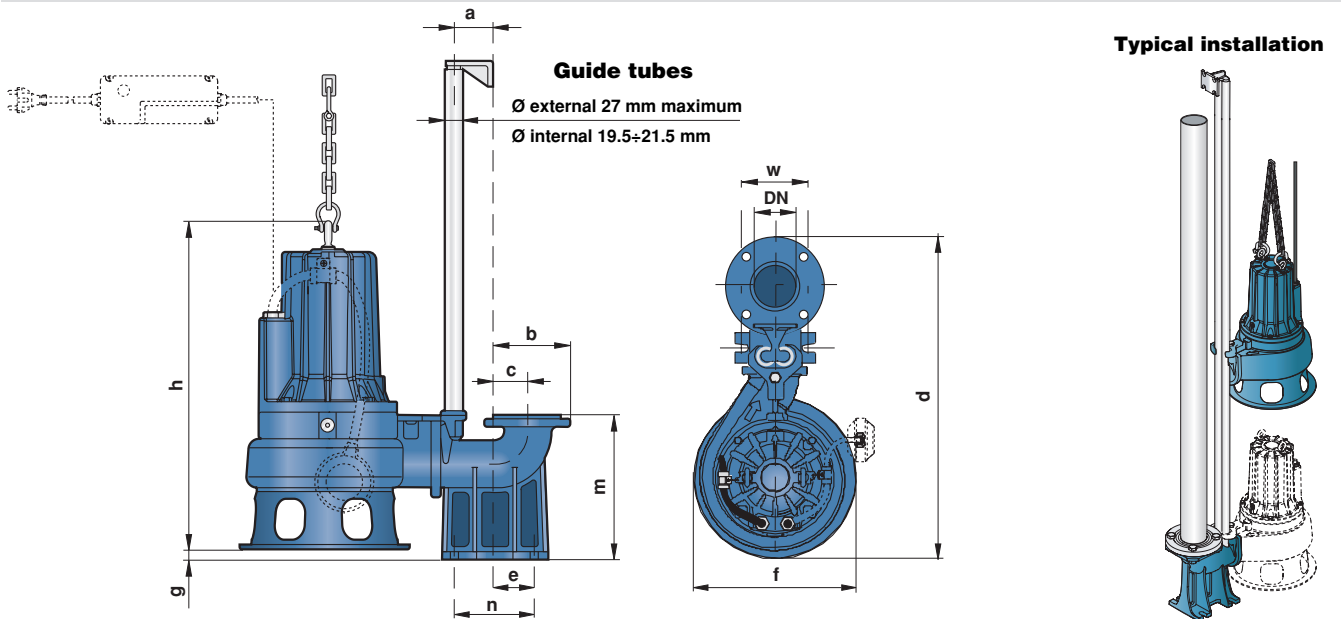

| TYPE | | PORT DN | passage of solid bodies | DIMENSIONS mm | | | | | | | | | | kg* | | |
|--------------|-------------|---------|-------------------------|---------------|-----|-----|-----|-----|-----|---------|---------|-----|-----|------|------|------|
| Single-phase | Three-phase | | | a | b | c | d | e | f | g | h | m | n | w | 1~ | 3~ |
| PVXCm 15/50 | PVXC 15/50 | 2 1/2" | Ø 50 mm | 60 | 116 | 51 | 501 | 62 | 270 | 10 | 387 | 200 | 120 | 72 | 42.0 | 40.0 |
| PVXCm 20/50 | PVXC 20/50 | | | | | | | | | | 397/387 | | | | 43.8 | 42.3 |
| PVXCm 30/50 | PVXC 30/50 | | | | | | | | | | 405 | | | | 49.7 | 43.8 |
| PVXCm 15/70 | PVXC 15/70 | 3" | Ø 70 mm | 150 | 70 | 585 | 95 | 300 | 10 | 405 | 256 | 150 | 92 | 53.0 | 50.7 | |
| PVXCm 20/70 | PVXC 20/70 | | | | | | | | | 415/405 | | | | 54.9 | 53.0 | |
| PVXCm 30/70 | PVXC 30/70 | | | | | | | | | 415/405 | | | | 61.1 | 55.2 | |

(*weight including counterflange)