

Km1 asynchronous single-phase electric motors

Asynchronous single-phase electric motors, high quality, robust and with high efficiencies.



RATED POWERS AT 50 Hz

0.25 ÷ 2.2 kW (0.33 ÷ 3 HP) 2 pole

0.37 ÷ 1.5 kW (0.50 ÷ 2 HP) 4 pole

LIMITS OF USE

Rated voltage $\pm 5\%$

Environment temperature up to $+40\text{ }^{\circ}\text{C}$

Altitude up to 1000 metres a.s.l.

CONSTRUCTION AND SAFETY STANDARDS

EN 60034-1

IEC 34-1

CEI 2-3



GUARANTEE 2 YEARS subject to our general terms of sale.

CONSTRUCTION CHARACTERISTICS

- **MOTOR:** The asynchronous single-phase motors of the **Km1** series are of closed type, with external ventilation and permanent capacitor, suitable for continuous duty.

- the motor casing is made of die-cast aluminium with a top terminal box containing the capacitor and power cable connections.
- the stator pack is made of magnetic sheet metal with a low loss figure.
- the stator is machine wound using class H double insulated wire with the head precision tied and shaped. Resin impregnation is carried out in a continuous automated process using class F polyester resin for reliable insulation and optimum heat transmission.

- **MOTOR CASING:** aluminium
 - **SHIELDS:** die-cast aluminium.
 - **SHIELD:** fan end in technopolymer for motor H 56.
 - **FAN:** in glass-filled thermoplastic.
 - **ROTOR:** die-cast, dynamically balanced, with shielded bearings, greased for life.
 - **TERMINAL BOX:** with cable clamp.
 - **CAPACITOR:** permanent, to standard VDE-IMQ.
 - **INSULATION:** class F.
 - **PROTECTION:** IP 44 complying with IEC 34-5
 - **BALANCING:** complying degree N of standard IEC 34-14.
 - **PAINTING:** the surface protection of the motor is obtained through a process of pickling, phosphating, passivation and a two coat electrostatic paint, oven cured.
- Km 1:** single-phase 230 V - 50 Hz.

OPTIONS ON REQUEST

- ⇒ protection IP 55
- ⇒ different voltages
- ⇒ motors for frequency 60 Hz

TECHNICAL CHARACTERISTICS

TYPE	Rated power		Revs 1/min	Rated current A	Condenser capacity μF	Power factor cos φ	Yield η	Static torque	Static current	J kgm ²	WEIGHT kg
	kW	HP						Rated torque	Rated current		

2 POLE SINGLE-PHASE - 230 V - 50 Hz

Km1 - 56 A/2	0.25	0.33	2730	1.8	8	0.90	63%	0.70	2.5	0.00020	3.35
Km1 - 63 B/2	0.37	0.50	2730	2.75	12.5	0.90	67%	0.70	3.1	0.00035	4.6
Km1 - 71 A/2	0.37	0.50	2800	3.0	10	0.83	65%	0.72	3.4	0.00045	6.8
Km1 - 71 B/2	0.55	0.75	2800	4.2	20	0.86	66%	0.70	3.0	0.00053	8.0
Km1 - 71 C/2	0.75	1	2800	5.2	25	0.93	68%	0.71	3.2	0.00058	8.0
Km1 - 80 B/2	1.1	1.5	2800	7.5	35	0.90	72%	0.77	3.3	0.00120	11.6
Km1 - 80 C/2	1.5	2	2800	9.7	45	0.93	74%	0.70	3.5	0.00140	12.6
Km1 - 90 S/2	1.5	2	2850	9.6	45	0.93	74%	0.72	3.6	0.00130	15.7
Km1 - 90 LB/2	2.2	3	2840	16.0	50	0.83	76%	0.70	3.6	0.00260	17.2

4 POLE SINGLE-PHASE - 230 V - 50 Hz

Km1 - 71 B/4	0.37	0.50	1380	3.1	14	0.91	62%	0.75	2.6	0.00073	7.8
Km1 - 80 A/4	0.55	0.75	1400	4.5	20	0.93	62%	0.78	2.6	0.00220	9.8
Km1 - 80 B/4	0.75	1	1400	5.5	25	0.95	65%	0.73	2.7	0.00280	11.5
Km1 - 90 S/4	1.1	1.5	1420	7.8	31.5	0.98	67%	0.72	2.6	0.00370	14.0
Km1 - 90 LA/4	1.5	2	1420	10.8	40	0.95	70%	0.75	2.8	0.00490	17.0

DIMENSIONS

FRAME SIZE B3 (IM 1001)

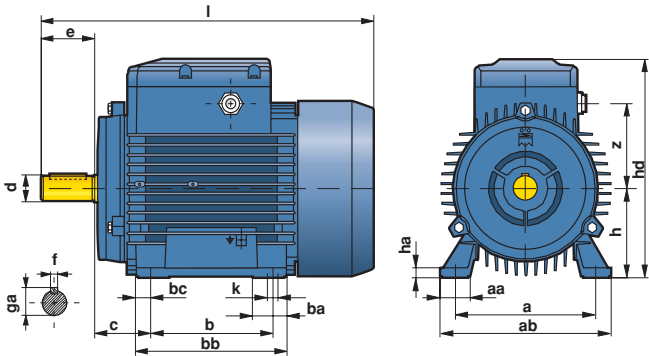

FRAME SIZE B5 (IM 3001)

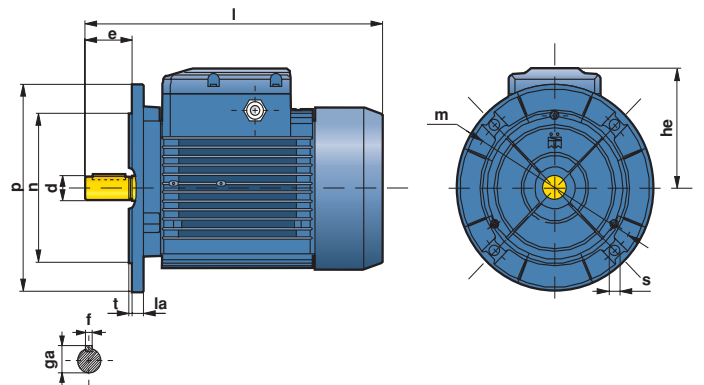

FRAME SIZE B14 (IM 3601)

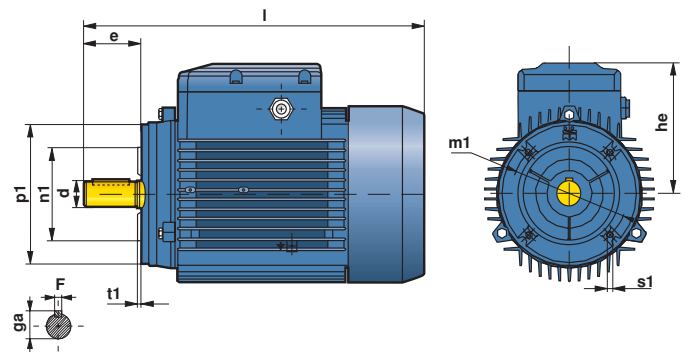

Italian
Electrical
Committee

Authorisation n° prot. 1064 / 27.3.87

TYPE		DIMENSIONS mm																													
2 Pole	4 Pole	a	aa	ab	b	ba	bb	bc	c	d	e	f	ga	h	ha	hd	he	k	l	la	m	m1	n	n1	p	p1	s	s1	t	t1	z
Km1-56 A/2	—	90	20	110	71	20	90	10.5	36	9	20	3	10.2	56	8	121	65	14	181	8	100	65	80	50	120	80	7	M5	3	2.5	45
Km1-63 B/2	—	100	22	120	80	23.5	98	9	40	11	23	4	12.5	63	8	152	91	7	209	9	115	75	95	60	140	90	9	M5	3	2.5	49.5
Km1-71 A/2	—	112	23	134	90	24.5	110	10	45	14	30	5	16	71	8	162.5	91.5	7	243	9	130	85	110	70	160	105	9.5	M6	3.5	2.5	61
Km1-71 B/2	Km1-71 B/4	112	23	134	90	24.5	110	10	45	14	30	5	16	71	8	162.5	91.5	7	243	9	130	85	110	70	160	105	9.5	M6	3.5	2.5	61
Km1-71 C/2	—	112	23	134	90	24.5	110	10	45	14	30	5	16	71	8	162.5	91.5	7	243	9	130	85	110	70	160	105	9.5	M6	3.5	2.5	61
—	Km1-80 A/4	125	27.5	152	100	32	124	12	50	19	40	6	21.5	80	10	202.5	122.5	9	279	10.5	165	100	130	80	200	120	11.5	M6	3.5	3	69
—	Km1-80 B/4	125	27.5	152	100	32	124	12	50	19	40	6	21.5	80	10	202.5	122.5	9	279	10.5	165	100	130	80	200	120	11.5	M6	3.5	3	69
Km1-80 B/2	—	125	27.5	152	100	32	124	12	50	19	40	6	21.5	80	10	202.5	122.5	9	279	10.5	165	100	130	80	200	120	11.5	M6	3.5	3	69
Km1-80 C/2	—	125	27.5	152	100	32	124	12	50	19	40	6	21.5	80	10	202.5	122.5	9	279	10.5	165	100	130	80	200	120	11.5	M6	3.5	3	69
Km1-90 S/2	Km1-90 S/4	140	30	170	100	32.5	125	12.5	56	24	50	8	27	90	10	218.5	128.5	9	297	10	165	115	130	95	200	140	11.5	M8	3.5	3	75
—	Km1-90 LA/4	140	30	170	125	32.5	150	12.5	56	24	50	8	27	90	10	218.5	128.5	9	322	10	165	115	130	95	200	140	11.5	M8	3.5	3	75
Km1-90 LB/2	—	140	30	170	125	32.5	150	12.5	56	24	50	8	27	90	10	218.5	128.5	9	322	10	165	115	130	95	200	140	11.5	M8	3.5	3	75