

# JSW3 “JET” self-priming pumps



## RANGE OF PERFORMANCE

Flow rate up to 160 l/min (9.6 m<sup>3</sup>/h)  
Head up to 96 m

## LIMITS OF USE

Manometric suction lift up to 9 m  
Liquid temperature up to + 40°C  
Environment temperature up to + 40°C

## CONSTRUCTION AND SAFETY STANDARDS

EN 60 335-1  
IEC 335-1  
CEI 61-150

EN 60034-1  
IEC 34-1  
CEI 2-3



## INSTALLATION AND USE

They are recommended for pumping clean water and liquids that are chemically non aggressive to the materials from which the pump is made. **JSW SELF-PRIMING PUMPS ARE DESIGNED FOR SUCTION LIFTS AND CAN BE POSITIONED ABOVE THE WATER SOURCE, INCLUDING APPLICATIONS WITH AIR ENTRAINED IN THE WATER. DUE TO THEIR RELIABILITY AND LOW MAINTENANCE, THEY ARE RECOMMENDED FOR DOMESTIC USE, INCLUDING WATER DISTRIBUTION (AS PART OF A PRESSURE SET), GARDEN IRRIGATION, ETC.**  
The pumps must be installed in enclosed places, or at least protected against inclement weather.

**GUARANTEE 2 YEARS** subject to our general terms of sale.

## CONSTRUCTION CHARACTERISTICS

- **PUMP BODY:** cast iron, with threaded ports ISO 228/1.
- **BODY BACK-PLATE:** cast iron.
- **EJECTOR ASSEMBLY:** technopolymer (approved for drinking water).
- **IMPELLER:** brass.
- **MOTOR SHAFT:** stainless steel EN 10088-3 - 1.4104.
- **MECHANICAL SEAL:** ceramic - graphite - NBR.
- **ELECTRIC MOTOR:** the pumps are close-coupled to a carefully matched PEDROLLO electric motor, quiet running, totally enclosed fan cooled (TEFC), suitable for continuous duty.  
**JSWm:** single-phase 230 V - 50 Hz with capacitor and thermal overload protector.  
**JSW:** three-phase 230/400 V - 50 Hz.
- **INSULATION:** class F. ● **PROTECTION:** IP 44.
- **REGISTERED MODEL n° 72753.**

## OPTIONS ON REQUEST

- ⇒ special mechanical seal
- ⇒ other voltages or frequency 60 Hz

**CURVES AND PERFORMANCE DATA AT n= 2900 1/min**

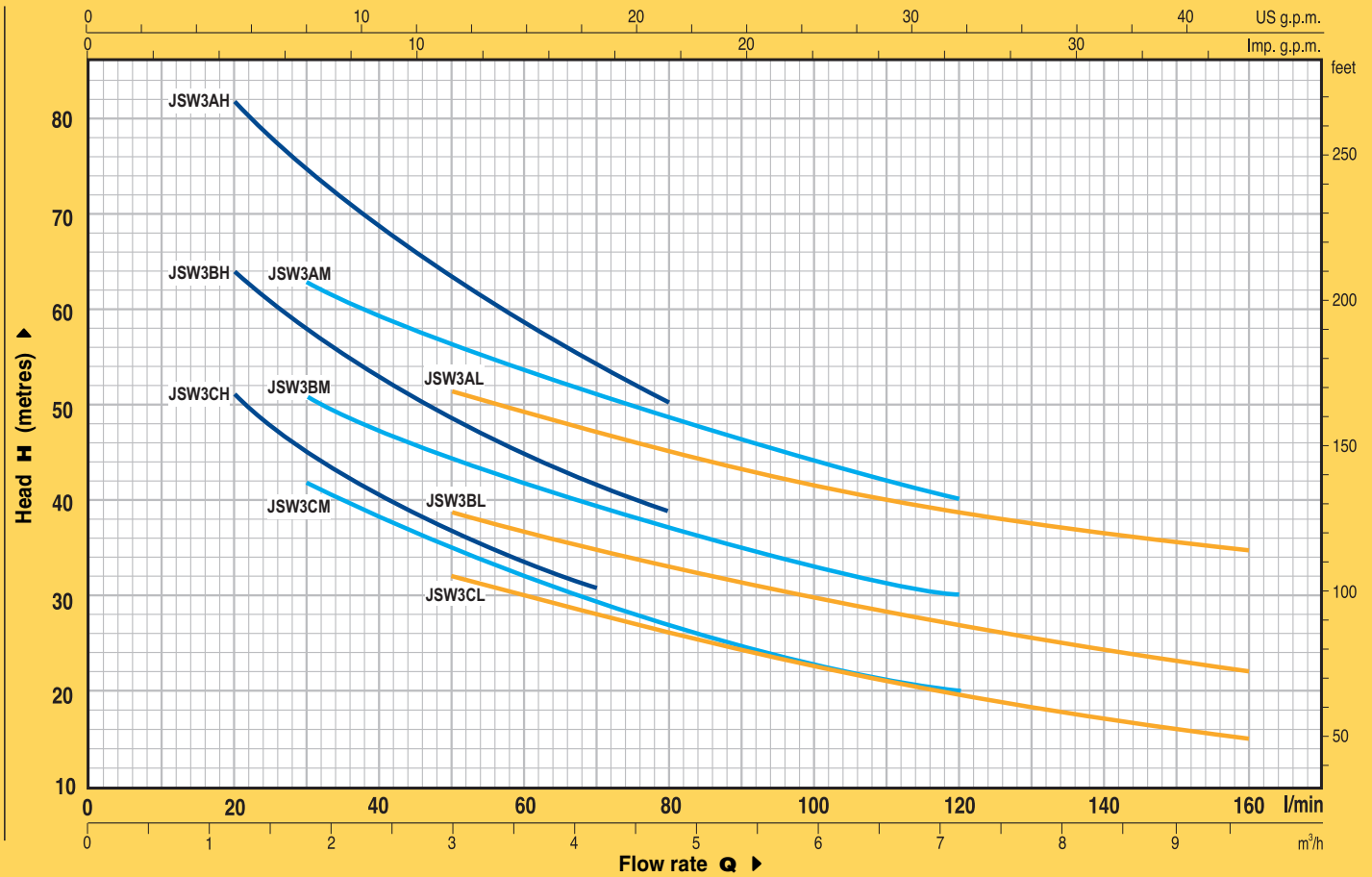

TYPE		POWER		Q	Flow rate																		
Single-phase	Three-phase	kW	HP		m³/h	0	0.6	0.9	1.2	1.5	1.8	2.1	2.4	2.7	3.0	3.6	4.2	4.8	6.0	7.2	8.4	9.6	
				l/min	0	10	15	20	25	30	35	40	45	50	60	70	80	100	120	140	160		
JSWm 3CH	JSW 3CH	1.1	1.5	H metres	64	60	55	51	48	45	42.5	40	39	37	34	31							
JSWm 3BH	JSW 3BH	1.5	2		76	70	67	64	61	58	55.5	53	51	49	45	41	39						
---	JSW 3AH	2.2	3		96	90	86	82	79	75	71.5	69	66	64	58	54	50						
JSWm 3CM	JSW 3CM	1.1	1.5		52	50	48	45	44	42	40	38	37	35	32	29	27	23	20				
JSWm 3BM	JSW 3BM	1.5	2		60	58	56	54	52	51	49	47	46	45	42	39	37	33	30				
---	JSW 3AM	2.2	3		74	70	68	67	65	63	61	59	58	56	54	51	49	44	40				
JSWm 3CL	JSW 3CL	1.1	1.5		42	40	39	38	37	36	35	34	33	32	30	28	26	23	20	17	15		
JSWm 3BL	JSW 3BL	1.5	2		51	48	46	45	44	43	42	41	40	39	37	35	33	30	27	24	22		
---	JSW 3AL	2.2	3		62	60	58	57	56	55	54	53	52	51	49	47	45	42	39	36.5	35		

Q = Flow rate H = Total manometric head

Tolerance of the performance curves according to EN ISO 9906 App. A.

**DIMENSIONS AND WEIGHTS**

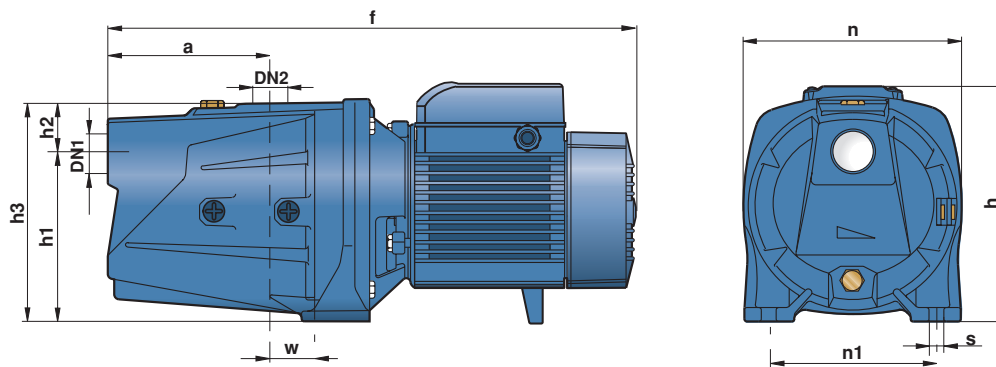

TYPE		PORTS		DIMENSIONS mm										kg	
Single-phase	Three-phase	DN1	DN2	a	f	h	h1	h2	h3	n	n1	w	s	1~	3~
JSWm 3CH	JSW 3CH	1 1/4"	1"	155	523	242	165	43	208	206	164	30	11	25.4	23.5
JSWm 3BH	JSW 3BH													26.5	25.7
---	JSW 3AH													-	26.8
JSWm 3CM	JSW 3CM													25.4	23.5
JSWm 3BM	JSW 3BM													26.5	25.7
---	JSW 3AM													-	26.8
JSWm 3CL	JSW 3CL													25.4	23.5
JSWm 3BL	JSW 3BL													26.5	25.7
---	JSW 3AL													-	26.8