

JSW2 “JET” self-priming pumps



RANGE OF PERFORMANCE

Flow rate up to 80 l/min (4.8 m³/h)
Head up to 70 m

LIMITS OF USE

Manometric suction lift up to 9 m
Liquid temperature up to + 40°C
Environment temperature up to + 40°C

CONSTRUCTION AND SAFETY STANDARDS

EN 60 335-1	EN 60034-1
IEC 335-1	IEC 34-1
CEI 61-150	CEI 2-3



INSTALLATION AND USE

They are recommended for pumping clean water and liquids that are chemically non aggressive to the materials from which the pump is made.

JSW SELF-PRIMING PUMPS ARE DESIGNED FOR SUCTION LIFTS AND CAN BE POSITIONED ABOVE THE WATER SOURCE, INCLUDING APPLICATIONS WITH AIR ENTRAINED IN THE WATER. DUE TO THEIR RELIABILITY AND LOW MAINTENANCE, THEY ARE RECOMMENDED FOR DOMESTIC USE, INCLUDING WATER DISTRIBUTION (AS PART OF A PRESSURE SET), GARDEN IRRIGATION, ETC.

The pumps must be installed in enclosed places, or at least protected against inclement weather.

GUARANTEE 2 YEARS subject to our general terms of sale.

CONSTRUCTION CHARACTERISTICS

- **PUMP BODY:** cast iron, with threaded ports ISO 228/1.
- **BODY BACK-PLATE:** stainless steel AISI 304.
- **EJECTOR ASSEMBLY:** technopolymer (approved for drinking water).
- **IMPELLER:** brass.
- **MOTOR SHAFT:** stainless steel EN 10088-3 - 1.4104.
- **MECHANICAL SEAL:** ceramic - graphite -NBR.
- **ELECTRIC MOTOR:** the pumps are close-coupled to a carefully matched PEDROLLO electric motor, quiet running, totally enclosed fan cooled (TEFC), suitable for continuous duty.
JSWm: single-phase 230 V - 50 Hz with capacitor and thermal overload protector.
JSW: three-phase 230/400 V - 50 Hz.
- **INSULATION:** class F. ● **PROTECTION:** IP 44.
- **REGISTERED MODEL n° 72753.**

OPTIONS ON REQUEST

- ⇒ impeller in **technopolymer** (JSWm...X - JSW...X)
- ⇒ other voltages or frequency 60 Hz

CURVES AND PERFORMANCE DATA AT n= 2900 1/min

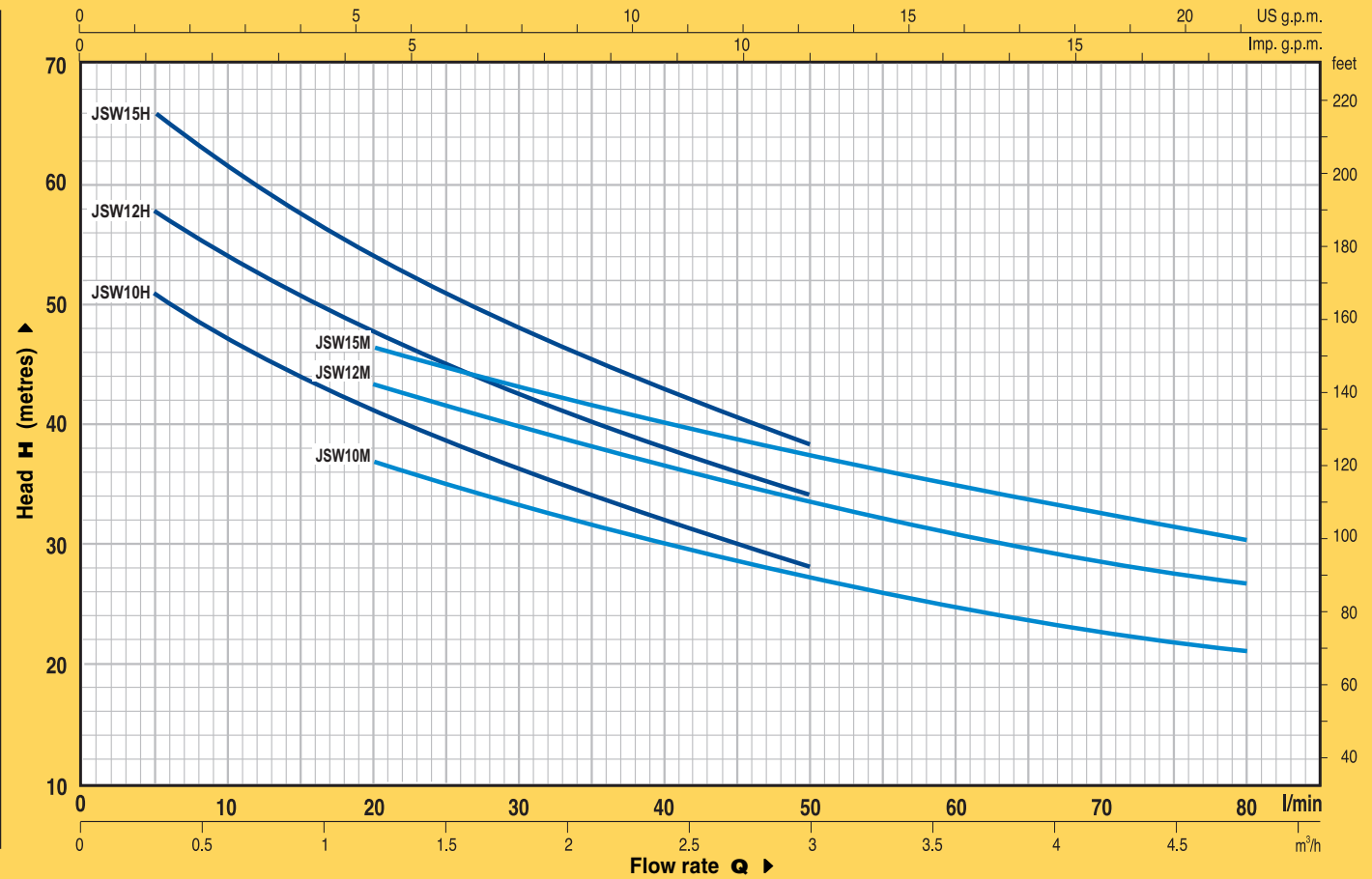

TYPE		POWER		Q	Flow rate														
Single-phase	Three-phase	kW	HP		m³/h	0	0.3	0.6	0.9	1.2	1.5	1.8	2.4	2.7	3.0	3.6	4.2	4.8	
JSWm 10H	JSW 10H	0.75	1	l/min	0	5	10	15	20	25	30	40	45	50	60	70	80		
JSWm 12H	JSW 12H	0.90	1.25	H metres	56	51	47	44	41	39	36	32	30	28					
JSWm 15H	JSW 15H	1.1	1.5		64	58	54	51	48	45	43	38	36	34					
JSWm 10M	JSW 10M	0.75	1		70	66	62	58	54	51	48	43	41	38					
JSWm 12M	JSW 12M	0.90	1.25		46	42	40	38	37	35	33	30	29	27	25	23	21		
JSWm 15M	JSW 15M	1.1	1.5		50	48	46	44	42	41	39	36	35	33	31	29	27		
					55	52	50	48	46	45	43	40	39	37	35	33	30		

Q = Flow rate H = Total manometric head

Tolerance of the performance curves according to EN ISO 9906 App. A.

DIMENSIONS AND WEIGHTS

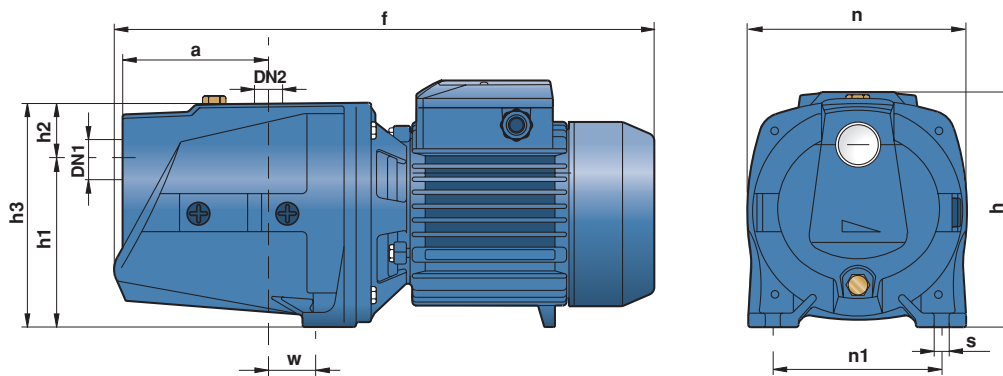

TYPE		PORTS		DIMENSIONS mm										kg	
Single-phase	Three-phase	DN1	DN2	a	f	h	h1	h2	h3	n	n1	w	s	1~	3~
JSWm 10H	JSW 10H	1"	1"	113.5	402	201	147	35	182	180	142	22	10	13.7	13.8
JSWm 12H	JSW 12H													15.0	14.0
JSWm 15H	JSW 15H													15.2	14.2
JSWm 10M	JSW 10M													13.7	13.8
JSWm 12M	JSW 12M													15.0	14.0
JSWm 15M	JSW 15M													15.2	14.2