



RANGE OF PERFORMANCE

Flow rate up to 50 l/min (3 m³/h)
Head up to 51 m

LIMITS OF USE

Manometric suction lift up to 9 m
Liquid temperature up to + 90°C (+55°C for diesel fuel)
Environment temperature up to + 40°C

CONSTRUCTION AND SAFETY STANDARDS

EN 60 335-1	EN 60034-1	CE
IEC 335-1	IEC 34-1	
CEI 61-150	CEI 2-3	

INSTALLATION AND USE

THEY ARE RECOMMENDED FOR PUMPING DIESEL FUEL, CLEAN WATER WITHOUT ABRASIVE PARTICLES AND LIQUIDS THAT ARE CHEMICALLY NON AGGRESSIVE TO THE MATERIALS FROM WHICH THE PUMP IS MADE. DUE TO THEIR OPERATING PRINCIPLE, THEY ARE IDEAL WHERE A COMPACT SELF-PRIMING PUMP IS NEEDED OR WHERE LIQUID SUPPLY IS IRREGULAR OR CONTAINS AIR. The pumps must be installed in enclosed places, or at least protected against inclement weather.

GUARANTEE 2 YEARS subject to our general terms of sale.

CONSTRUCTION CHARACTERISTICS

- **PUMP BODY:** cast iron, with threaded ports ISO 228/1.
- **MOTOR BRACKET (patent n° 1289150):** aluminium with brass insert; reduces starting difficulties due to seizure of the impeller after long periods of inactivity.
- **IMPELLER:** brass of the star type with open radial vanes.
- **MOTOR SHAFT:** stainless steel EN 10088-3 - 1.4104.
- **MECHANICAL SEAL:** ceramic - graphite - VITON.
- **ELECTRIC MOTOR:** the pumps are close-coupled to a carefully matched PEDROLLO electric motor, quiet running, totally enclosed fan cooled (TEFC), suitable for continuous duty.
CKm: single-phase 230 V - 50 Hz with capacitor and thermal overload protector.
CK: three-phase 230/400 V - 50 Hz.
- **INSULATION:** class F. ● **PROTECTION:** IP 44.
- **REGISTERED MODEL**

OPTIONS ON REQUEST

- ⇒ CKm/INT version with switch and power cable with Schuko plug
- ⇒ CKm 50-BP/NZ aluminium trigger dispensing nozzle and 4 metre spiral reinforced hose.
- ⇒ special mechanical seal
- ⇒ other voltages or frequency 60 Hz
- ⇒ protection IP 55

CURVES AND PERFORMANCE DATA AT n= 2900 1/min

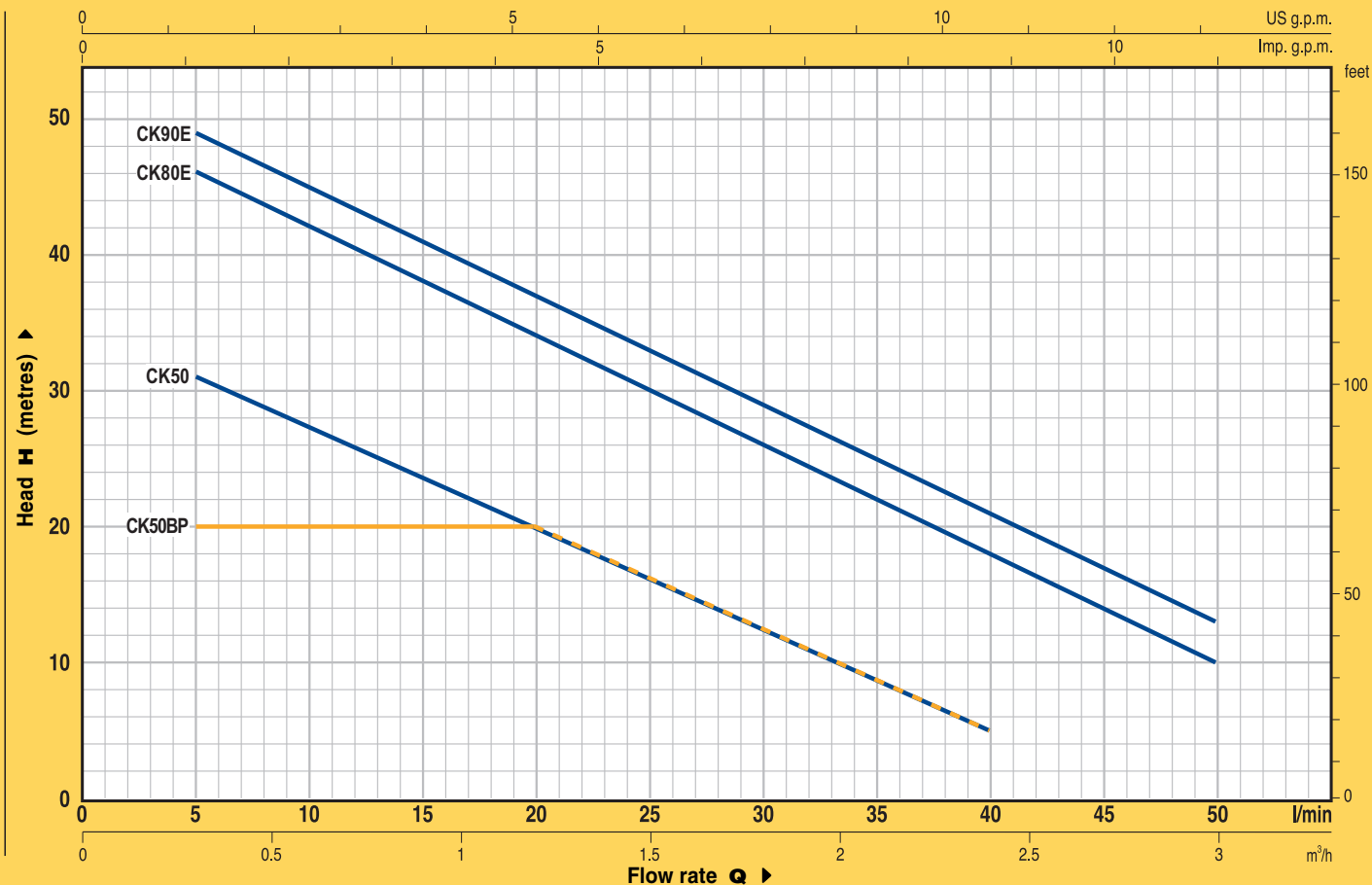

TYPE		POWER		Q	H metres										
Single-phase	Three-phase	kW	HP		m³/h	0	0.3	0.6	0.9	1.2	1.5	1.8	2.1	2.4	3.0
				l/min	0	5	10	15	20	25	30	35	40	50	
CKm 50	CK 50	0.37	0.50	H metres	35	31	27	24	20	16	13	9	5		
CKm 50-BP	CK 50-BP	0.25	0.33		20	20	20	20	20	16.5	13	9	5		
CKm 80-E	CK 80-E	0.60	0.85		48	46	42	38	34	30	26	22	18	10	
CKm 90-E	CK 90-E	0.75	1		51	49	45	41	37	33	29	25	21	13	

Q = Flow rate H = Total manometric head

Tolerance of the performance curves according to EN ISO 9906 App. A.

DIMENSIONS AND WEIGHTS

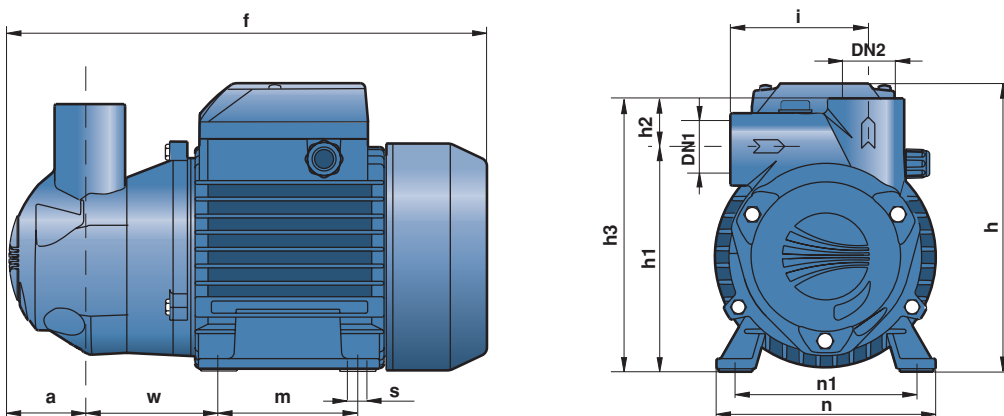

TYPE		PORTS		DIMENSIONS mm													kg	
Single-phase	Three-phase	DN1	DN2	a	f	h	h1	h2	h3	i	m	n	n1	w	s	1~	3~	
CKm 50	CK 50	3/4"	3/4"	41	260	159	128	25	153	75	80	120	100	69	7	7.3	6.8	
CKm 50-BP	CK 50-BP			44	263											11.6	10.8	
CKm 80-E	CK 80-E	1"	1"	50	296	179	136	31	167	81	90	134	112	77		11.8	11.0	
CKm 90-E	CK 90-E																	