

Bz pumps with bronze body



RANGE OF PERFORMANCE

Flow rate up to 90 l/min (5.4 m³/h)
Head up to 55 m.

LIMITS OF USE

Liquid temperature up to + 90°C
Environment temperature up to + 40°C

CONSTRUCTION AND SAFETY STANDARDS

EN 60034-1
IEC 34-1
CEI 2-3



INSTALLATION AND USE

They are recommended for pumping clean water without abrasive particles and liquids that are chemically non aggressive to the materials from which the pump is made. **THE NON-FERROUS CONSTRUCTION GUARANTEES AGAINST RUST AND OXIDATION. THE COMPACT DESIGN AND HYDRAULIC CHARACTERISTICS SUIT INDUSTRIAL APPLICATIONS INCLUDING COOLING AND CONDITIONING SYSTEMS.**

The pumps must be installed in enclosed places, or at least protected against inclement weather.

GUARANTEE 2 YEARS subject to our general terms of sale.

CONSTRUCTION CHARACTERISTICS

- **PUMP BODY:** bronze, with threaded ports ISO 228/1.
- **MOTOR BRACKET** (patent n° 1289150) PK-Bz, PQ-Bz: aluminium with brass front insert.
- **BODY BACK-PLATE:** CP-Bz: stainless steel AISI 316.
- **IMPELLER:** PK-Bz, PQ-Bz: brass.
CP-Bz: stainless steel AISI 316
- **MOTOR SHAFT:** stainless steel AISI 316.
- **MECHANICAL SEAL:** ceramic - graphite - VITON.
- **ELECTRIC MOTOR:** induction motor, for continuous duty.
Single-phase: 230 V - 50 Hz with capacitor and thermal overload protector.
Three-phase: 230/400 V - 50 Hz.
- **INSULATION:** class F. ● **PROTECTION:** IP 44.

OPTIONS ON REQUEST

- ⇒ special mechanical seal
- ⇒ other voltages or frequency 60 Hz
- ⇒ protection IP 55
- ⇒ for liquids with higher temperatures
- ⇒ for environments with higher temperatures

CURVES AND PERFORMANCE DATA AT n= 2900 1/min

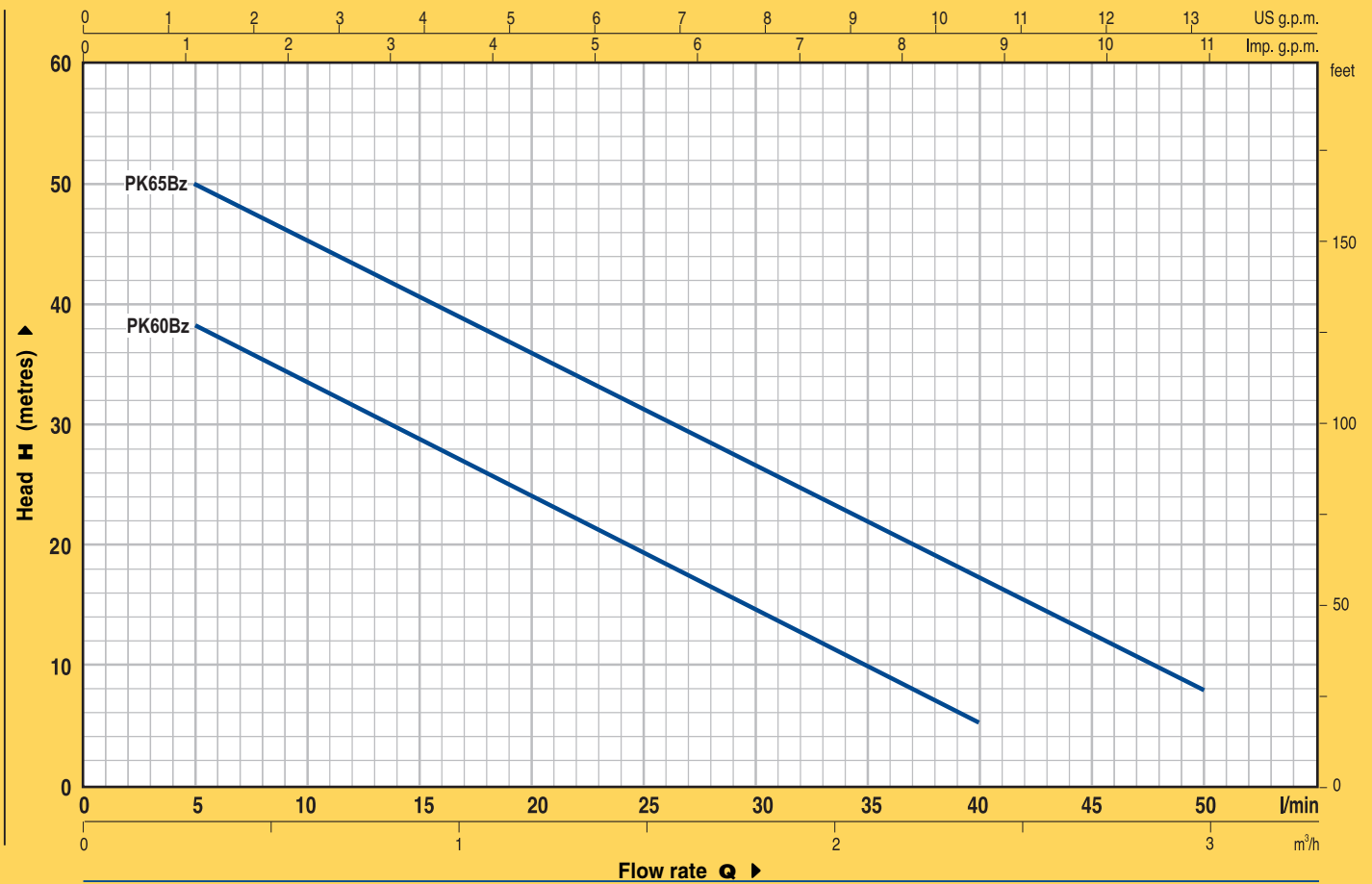

TYPE		POWER		Q	Flow rate												
Single-phase	Three-phase	kW	HP		m³/h	0	0.3	0.6	0.9	1.2	1.5	1.8	2.1	2.4	3.0		
PKm 60-Bz	PK 60-Bz	0.37	0.50	l/min	0	5	10	15	20	25	30	35	40	50			
PKm 65-Bz	PK 65-Bz	0.50	0.70	H metres	40	38	33.5	29	24	19.5	15	10	5				
					55	50	45.5	40.5	36	31	27	22	17	8			

Q = Flow rate H = Total manometric head

Tolerance of the performance curves according to EN ISO 9906 App. A.

DIMENSIONS AND WEIGHTS

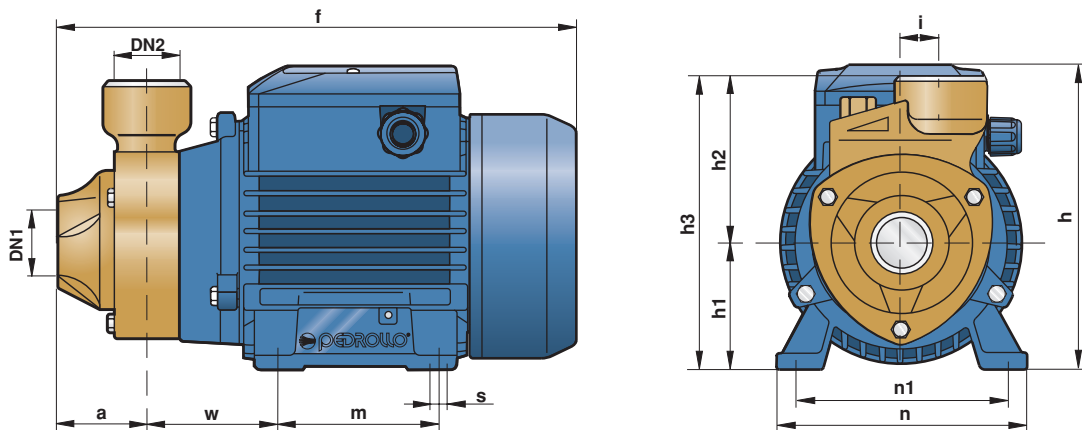

TYPE		PORTS		DIMENSIONS mm													kg	
Single-phase	Three-phase	DN1	DN2	a	f	h	h1	h2	h3	i	m	n	n1	w	s	1~	3~	
PKm 60-Bz	PK 60-Bz	1"	1"	42	243	152	63	75	138	20	80	120	100	55	7	5.7	5.7	
PKm 65-Bz	PK 65-Bz	1"	1"	48	258/250	152	63	80	143	20	80	120	100	55	7	8.1	6.8	

CURVES AND PERFORMANCE DATA AT n= 2900 1/min

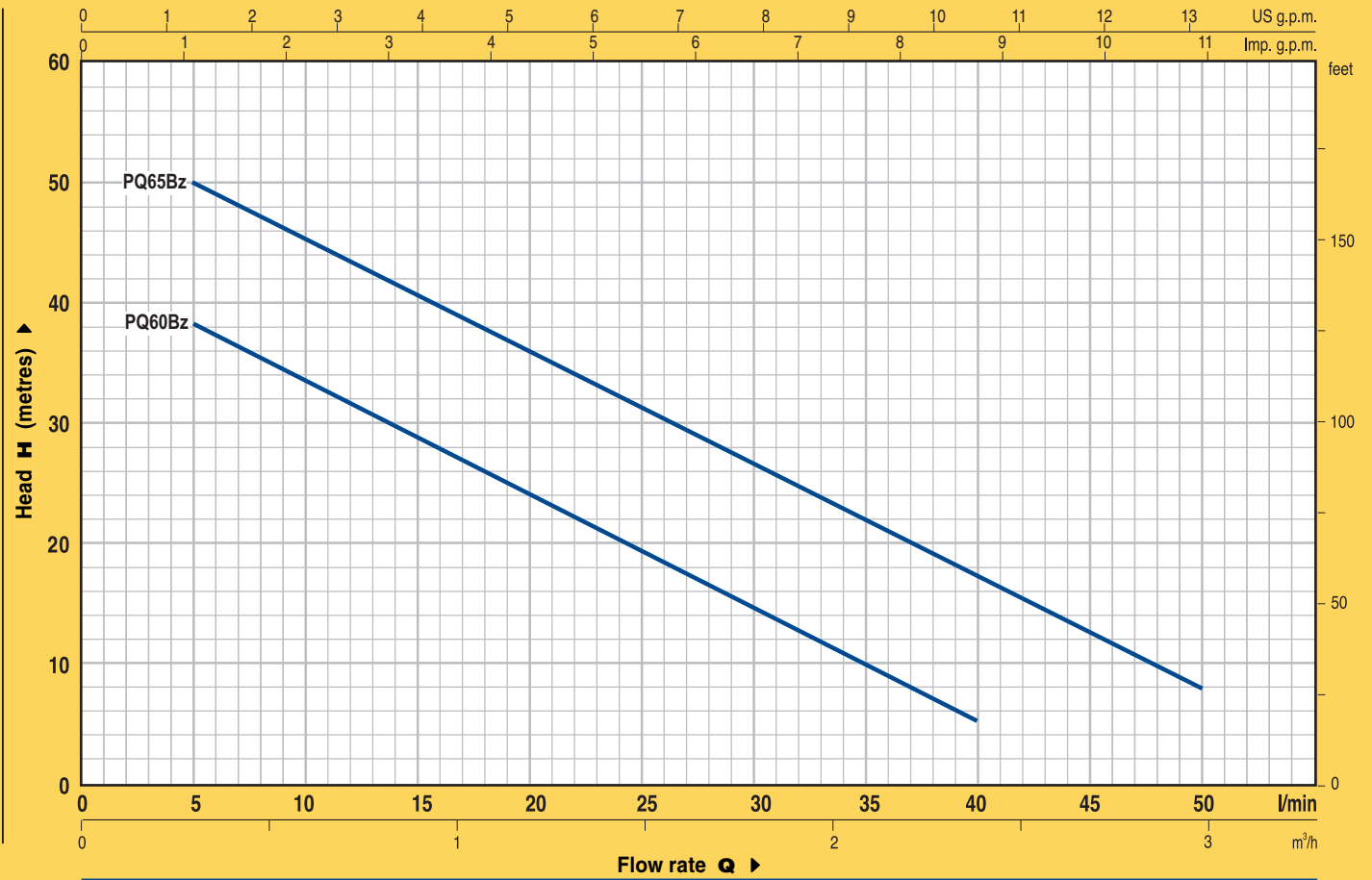

TYPE		POWER		Q	Flow rate										
Single-phase	Three-phase	kW	HP		m³/h	0	0.3	0.6	0.9	1.2	1.5	1.8	2.1	2.4	3.0
PQm 60-Bz	PQ 60-Bz	0.37	0.50	l/min	0	5	10	15	20	25	30	35	40	50	
PQm 65-Bz	PQ 65-Bz	0.50	0.70	H metres	40	38	33.5	29	24	19.5	15	10	5		
					55	50	45.5	40.5	36	31	27	22	17	8	

Q = Flow rate H = Total manometric head

Tolerance of the performance curves according to EN ISO 9906 App. A.

DIMENSIONS AND WEIGHTS

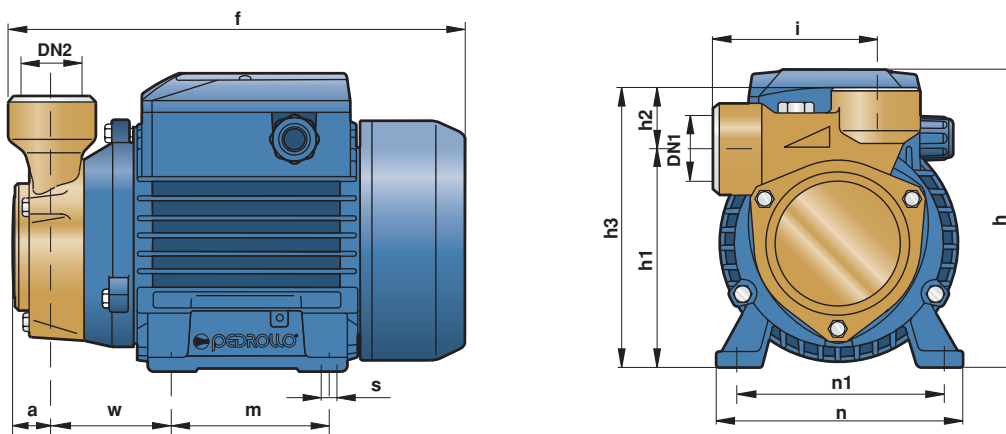

TYPE		PORTS		DIMENSIONS mm												kg	
Single-phase	Three-phase	DN1	DN2	a	f	h	h1	h2	h3	i	m	n	n1	w	s	1~	3~
PQm 60-Bz	PQ 60-Bz	1"	1"	22	223	152	108	30	138	78	80	120	100	55	7	5.5	5.5
PQm 65-Bz	PQ 65-Bz				234/227		113		143					57		7.4	6.6

CURVES AND PERFORMANCE DATA AT n= 2900 1/min

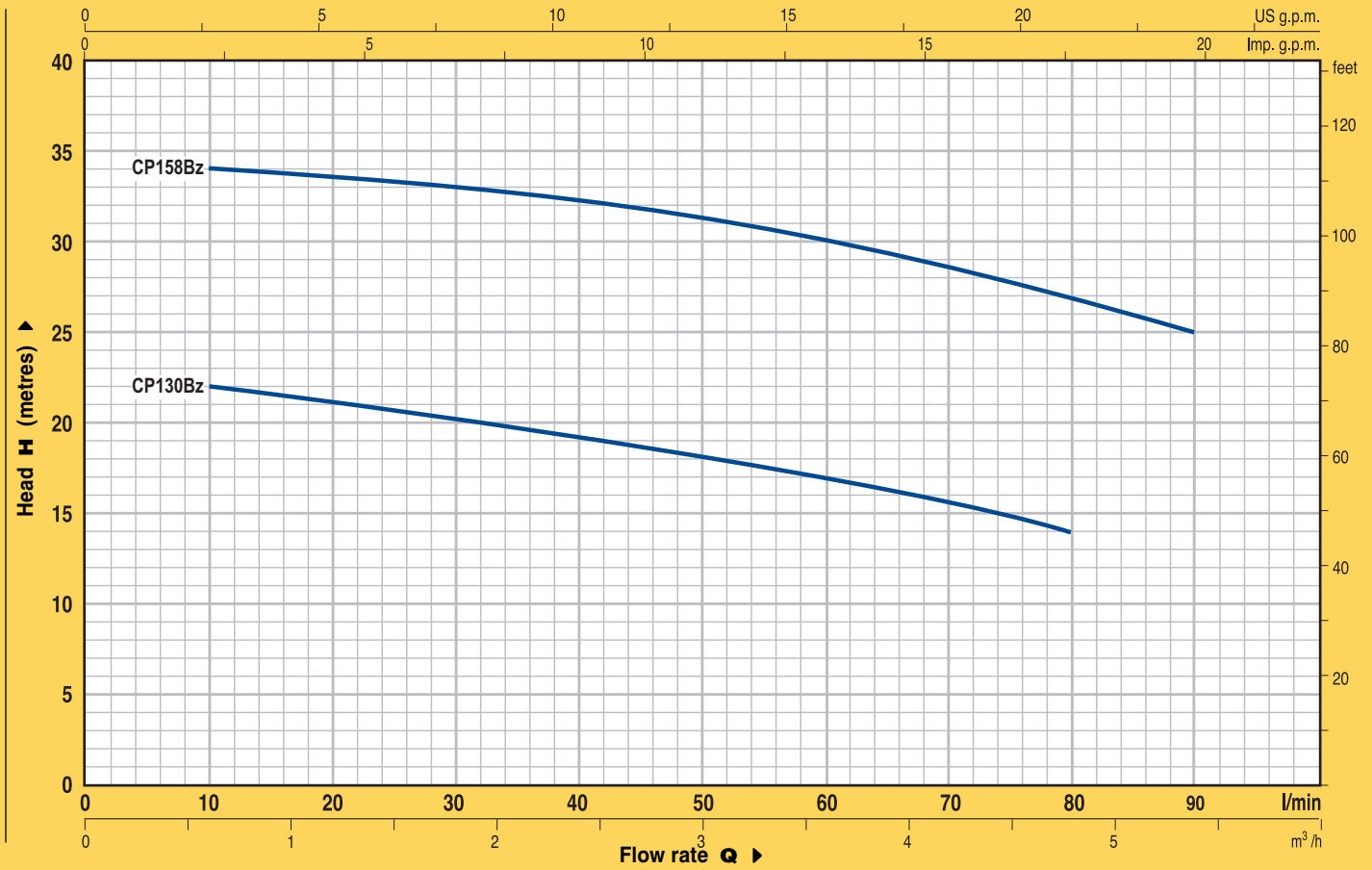

TYPE		POWER		Q	Flow rate									
Single-phase	Trifase	kW	HP		m³/h	0	0.6	1.2	1.8	2.4	3.0	3.6	4.2	4.8
CPm 130-Bz	CP 130-Bz	0.37	0.50	l/min	0	10	20	30	40	50	60	70	80	90
CPm 158-Bz	CP 158-Bz	0.75	1	H metres	23	22	21	20	19	18	17	15.5	14	25
					36	34	33.5	33	32.5	31.5	30	28.5	27	

Q = Flow rate H = Total manometric head

Tolerance of the performance curves according to EN ISO 9906 App. A.

DIMENSIONS AND WEIGHTS

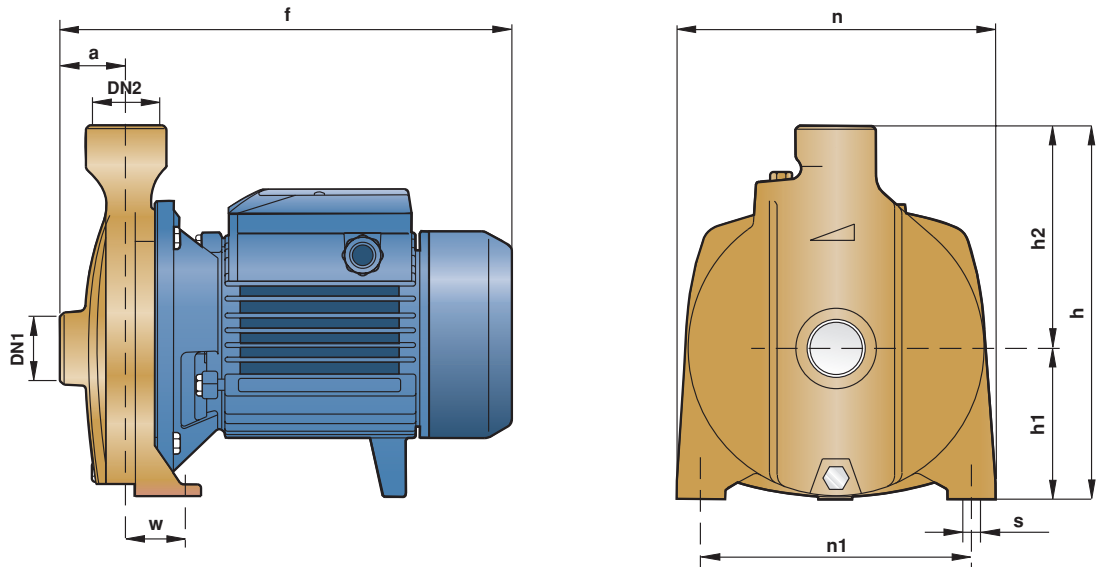

TYPE		PORTS		DIMENSIONS mm										kg	
Single-phase	Three-phase	DN1	DN2	a	f	h	h1	h2	n	n1	w	s	1~	3~	
CPm 130-Bz	CP 130-Bz	1"	1"	42	259	205	82	123	165	135	41	10	8.5	8.3	
CPm 158-Bz	CP 158-Bz				285	240	92	148	190	160	38		12.8	12.3	