

# 3-4CR

**multi-stage centrifugal pumps**  
stainless steel pump body

**Particularly quiet running with high efficiency and low power consumption. Suitable for domestic applications.**



## RANGE OF PERFORMANCE

Flow rate up to 120 l/min (7.2 m<sup>3</sup>/h)  
Head up to 50 m

## LIMITS OF USE

Manometric suction lift up to 7 m  
Liquid temperature up to + 40°C  
Environment temperature up to + 40°C

## CONSTRUCTION AND SAFETY STANDARDS

EN 60 335-1	EN 60034-1
IEC 335-1	IEC 34-1
CEI 61-150	CEI 2-3



## INSTALLATION AND USE

They are recommended for pumping clean water and liquids that are chemically non aggressive to the materials from which the pump is made. **DUE TO THEIR RELIABILITY AND QUIET RUNNING, THEY ARE SUITABLE FOR DOMESTIC APPLICATIONS INCLUDING WATER SUPPLIES (AS A PRESSURE SET), GARDEN IRRIGATION, ETC.** The pumps must be installed in enclosed places, or at least protected against inclement weather.

**GUARANTEE 2 YEARS** subject to our general terms of sale.

## CONSTRUCTION CHARACTERISTICS

- **PUMP BODY:** stainless steel AISI 304, with threaded ports ISO 228/1.
- **BODY BACK-PLATE:** stainless steel AISI 304.
- **IMPELLERS:** of the type with centrifugal radial flow, made of technopolymer (approved for drinking water).
- **MOTOR SHAFT:** stainless steel EN 10088-3 - 1.4104.
- **MECHANICAL SEAL:** ceramic - graphite - NBR.
- **ELECTRIC MOTOR:** the pumps are close-coupled to a carefully matched PEDROLLO electric motor, quiet running, totally enclosed fan cooled (TEFC), suitable for continuous duty.
  - 3-4CRm: single-phase 230 V - 50 Hz with capacitor and thermal overload protector.
  - 3-4CR: three-phase 230/400 V - 50 Hz.
- **INSULATION:** class F. ● **PROTECTION:** IP 44.

## OPTIONS ON REQUEST

- ⇒ special mechanical seal
- ⇒ other voltages or frequency 60 Hz

**CURVES AND PERFORMANCE DATA AT n= 2900 1/min**

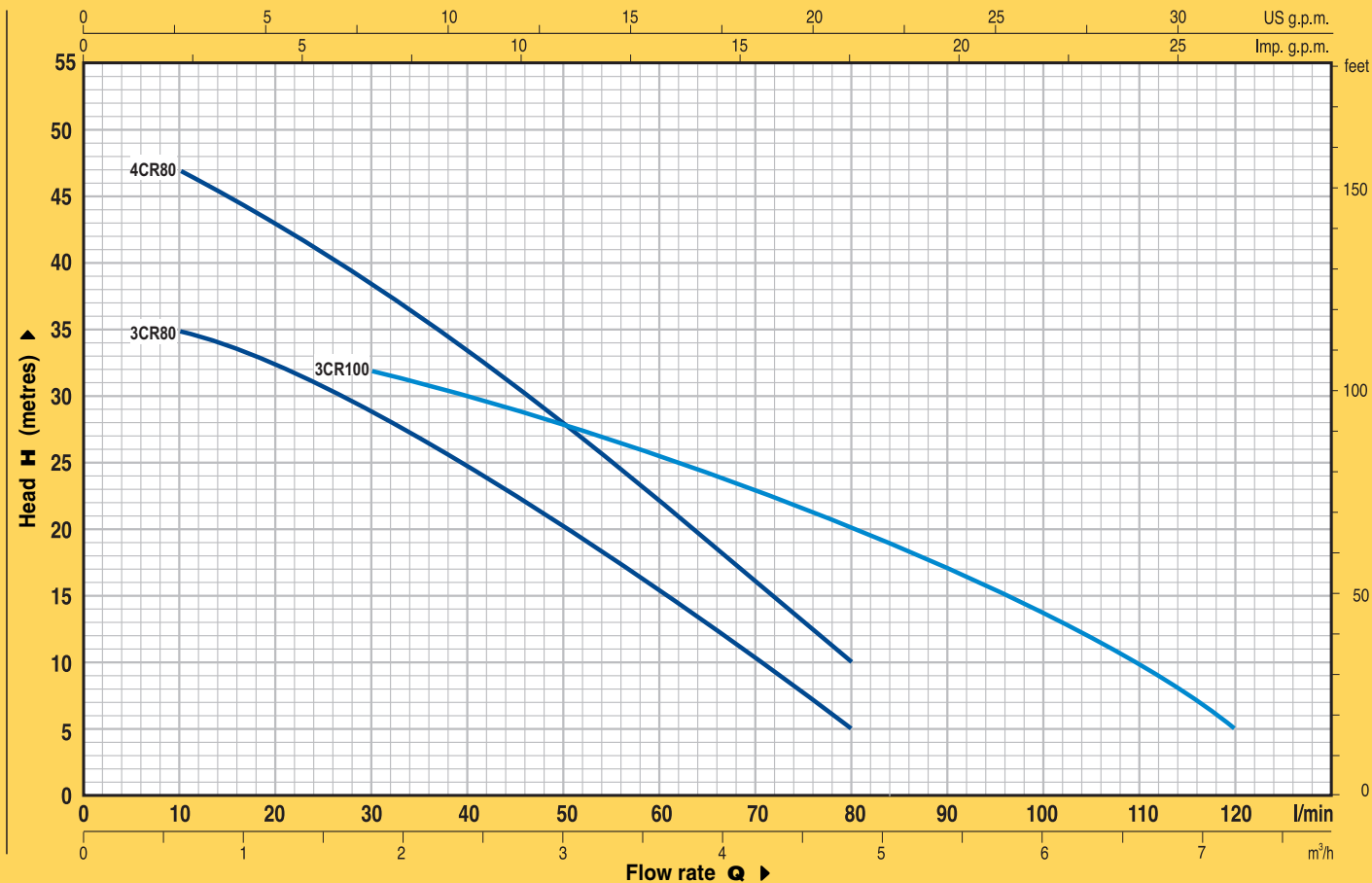

TYPE		POWER		Q	Flow rate																
Single-phase	Three-phase	kW	HP		m³/h	0	0.3	0.6	0.9	1.2	1.5	1.8	2.4	3.0	3.6	4.2	4.8	5.4	6.0	6.6	7.2
3CRm 80	3CR 80	0.45	0.60	l/min	0	5	10	15	20	25	30	40	50	60	70	80	90	100	110	120	
4CRm 80	4CR 80	0.60	0.85	H metres	38	36	35	34	32.5	31	29	25	20	15.5	10	5					
3CRm 100	3CR 100	0.60	0.85		50	48	47	45	43	40.5	38.5	33.5	28	22.5	16	10					
					36	35.5	35	34	33.5	32.5	32	30	28	25.5	23	20	17	13.5	10	5	

Q = Flow rate H = Total manometric head

Tolerance of the performance curves according to EN ISO 9906 App. A.

**DIMENSIONS AND WEIGHTS**

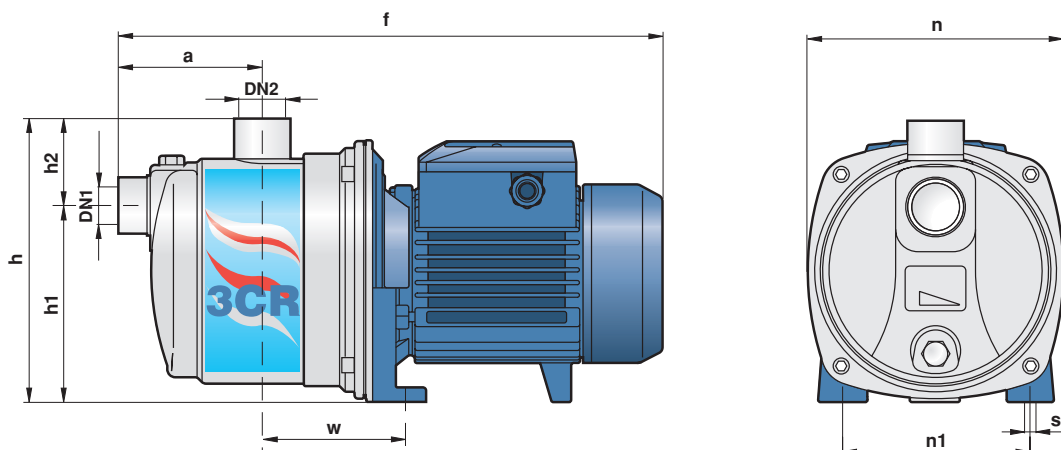

TYPE		PORTS		DIMENSIONS mm										kg	
Single-phase	Three-phase	DN1	DN2	a	f	h	h1	h2	n	n1	w	s	1~	3~	
3CRm 80	3CR 80	1"	1"	90	345	174	122	52	160	120	95	9	6.9	6.3	
4CRm 80	4CR 80				353/345								7.6	6.9	
3CRm 100	3CR 100				7.5								6.9		