

## DIMENSIONS IN INCHES SERIES Z

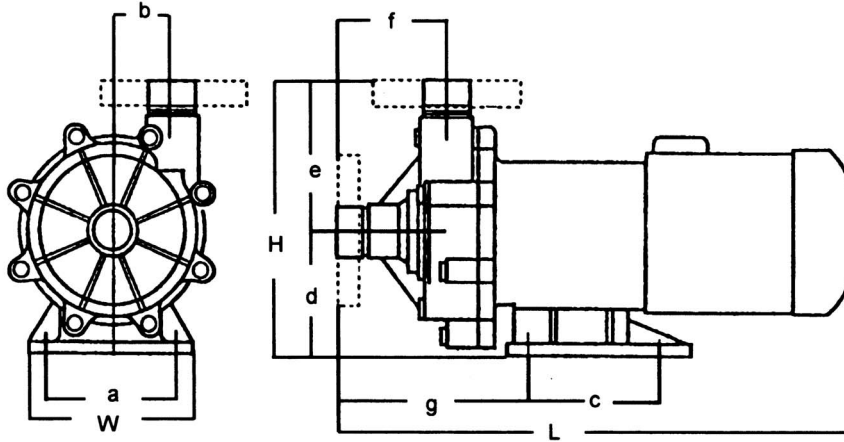

SERIES	PORT MNPT		W	H	L*	a	b	c	d	e	f	g
	IN	OUT										
Z40	1½	1½	5.62	8.52	19.35	4.33	2.01	3.89	3.78	4.74	3.42	5.83
Z41	1½	1½	6.30	10.00	20.83	5.12	2.27	5.12	4.53	5.47	4.03	7.25
Z42	2	1½	10.23	10.03	22.37	8.19	2.56	7.87	4.53	5.50	3.50	6.22
Z43	2	1½	10.23	10.03	22.37	8.19	2.56	7.87	4.53	5.50	3.50	6.22
Z45	2	1½	10.23	10.62	25.56	8.19	2.56	7.87	5.12	5.50	3.50	6.22

\*Varies with motor manufacturer

## PERFORMANCE SERIES Z

3450 RPM

S.G = 1.1

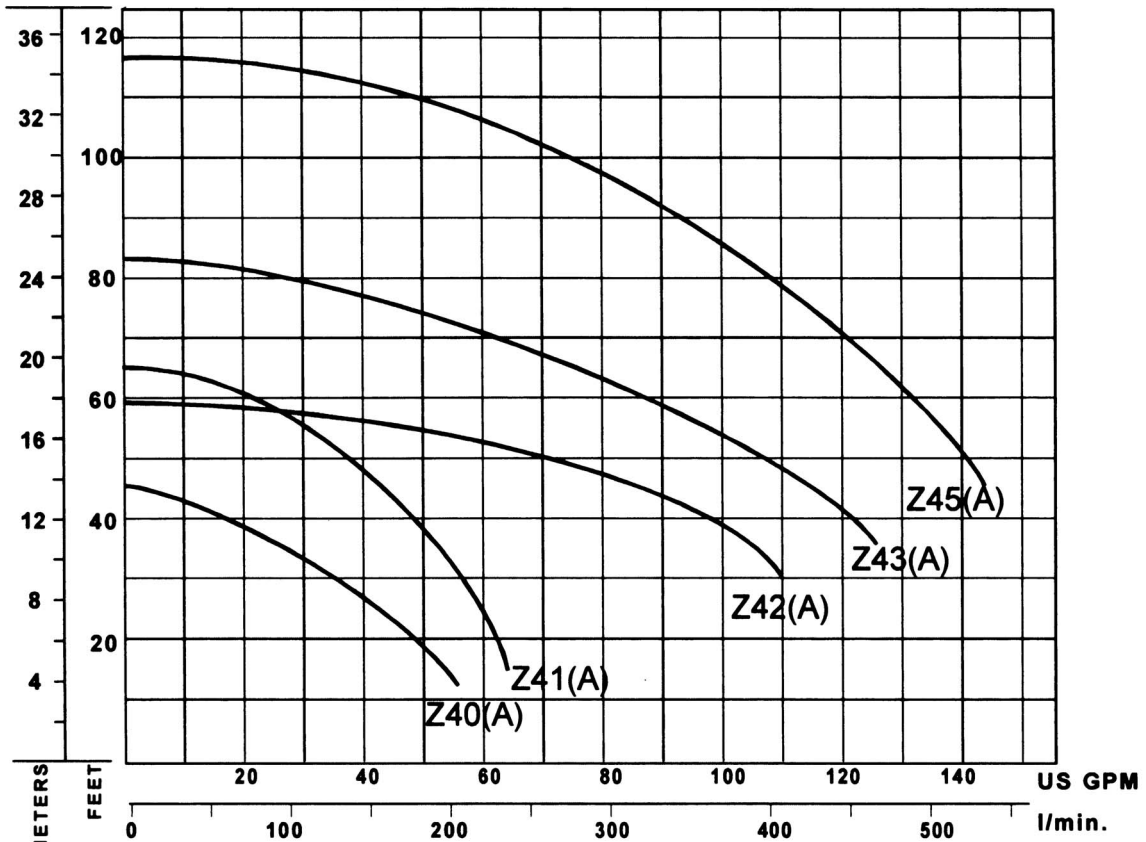

Impellers can be trimmed for higher S.G. solutions.  
Specifications subject to change without notice.