

COOLING PUMPS FOR HELIARC WELDING



OBERDORFER PUMPS

A Subsidiary of Thomas Industries Inc.



N1000R-66*



N95060GEC03

N95060GFC01

N95060GE IS NOT PICTURED



N1000R39

PUMP MAINTENANCE AND REPAIR

Oberdorfer gear pumps are essentially maintenance-free. If the pump is to be shut down for an extended period of time, it should be flushed thoroughly and filled with lubricating oil.

As a general rule, it is seldom economical to repair a worn out gear pump. However, if the gear chamber inside the pump body is still in good condition, the replacement of all interior parts by use of a repair kit may restore up to 80% of the original pump performance. Repair kit numbers and parts contained in each kit are listed on the parts lists on the reverse side.

PERFORMANCE

Pump #	RPM	PSI	0	20	40	60	80	100
N1000R39								
N95060GEC03	1725	GPM	1.5	1.4	1.3	1.2	1.1	1
N95060GFC01								
N1000R-66*	1725	GPM	2.1	1.9	1.8	1.7	1.6	1.5

GENERAL INFORMATION

Oberdorfer has a long history of supplying pumps to the welding machine industry. Ever since the Heliarc welding technology was developed, Oberdorfer pumps were used to circulate cooling liquid to the welder's torch.

Pump and electric motor are usually mounted on top or on the side of the coolant tank. A pressure relief valve built into the pump returns excess liquid directly to the tank rather than to the suction side of the pump, thus avoiding heat build-up in the pump.

Pump models N1000R39 and N1000R-66* are coupled to the electric motor with a flexible coupling. The N95060GEC03 and N95060GFC01 models are close-coupled to a carbonator motor by a circular clamp arrangement, offering a space-saving, compact design alternative. Pump model N95060GE is a retrofit for Miller Electric Mfg. Co.

The reasons for the wide acceptance of Oberdorfer pumps in the welding machine industry are reliability, long service life, and ease of maintenance. The pumps depicted on this page are being produced in quantities for several welding machine manufacturers in the U.S.A.

*Replaces the 1000R-53

TYPICAL PUMP INSTALLATION

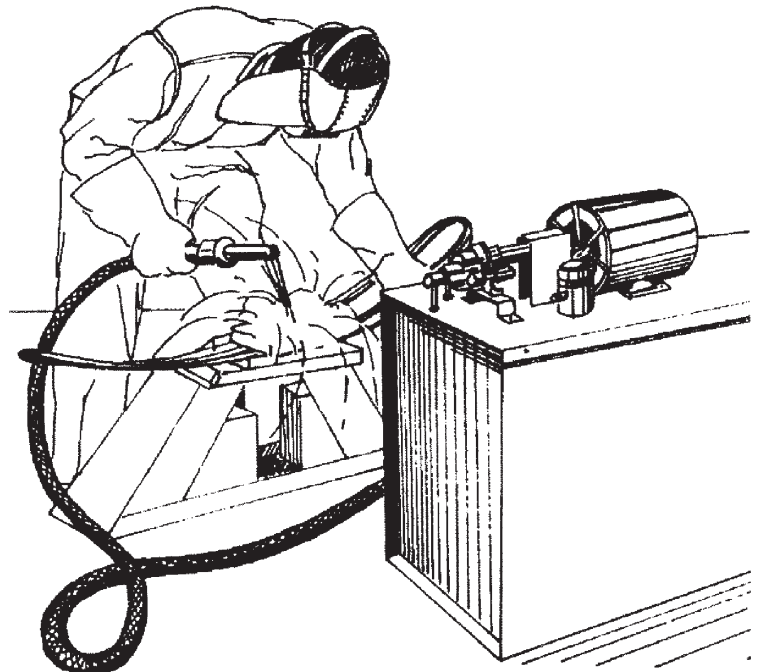

COOLING PUMPS FOR HELIARC WELDING



OBERDORFER PUMPS

A Subsidiary of Thomas Industries Inc.

EXPLODED VIEW AND PARTS LIST

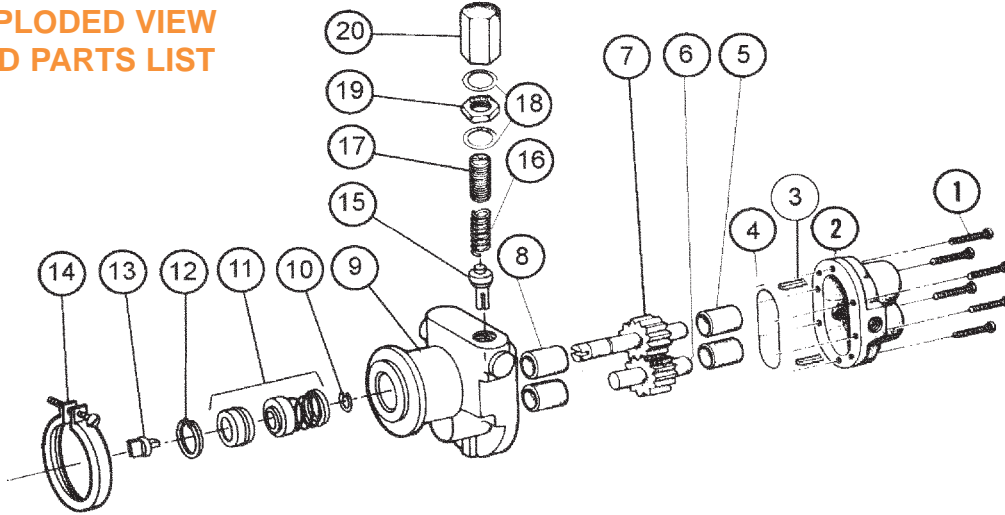

Pump #	Item Name	1	2	3	4	5	6	7	8	9	10
		Req.									
N95060GEC03	Screw	5506	9301NB5N	8885	9797-033	8990	32629	32884	5024	9305NN4R	5373
N5060GFC01	Screw	5506	9301NB5N	8885	9797-033	8990	32629	32884	5024	9305NN4R	5373
N95060GE	Screw	5506	9301NB5N	8885	9797-033	8990	32629	32884	8990	9305NNZR	5373

11	12	13	14	15	16	17	18	19	20	
Seal Assy.	Snap Ring	Coupler	Clamp	Poppet	Spring	Adj. Screw	Washer	Lock Nut	Valve Nut	Repair Kit*
1	1	1	1	1	1	1	2	1	1	
32584	7639	9175	8840	7640	5806	5766	6966	5774	5767	11936
32584	7639	9175	8840	7640	9718	----	----	----	----	11936
32584	7639	----	----	7640	5806	5766	6966	5774	5767	11937

* Repair Kit contains items 4,5,6,7, 8, 10, 11, 12

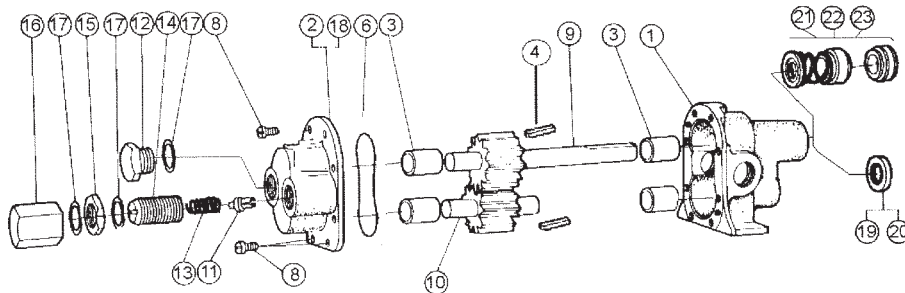

Pump #	Item Name	1	2	3	4	6	8	9	10	11	13	14	15	16	17	19,20	21,22,23	
		Req.																
N1000R39	Body	9313NB2N	9314NN5L	5024	8885	9797-033	5385	32133	32118	7640	5806	5766	5774	5767	6966	5007	----	11187
N1000R-66*	Body	9311NB4N	9314NN5L	5024	8885	9797-033	5385	32687	32584	7640	5806	5766	5774	5767	6966	----	32584	11925

* Repair Kit contains items 3, 6, 9 10 & Seal.