

BRONZE CLOSE COUPLED ROTARY GEAR PUMPS

**MODEL
N999
SERIES**

OBERDORFER PUMPS
A Subsidiary of Thomas Industries Inc.

MODEL N999 - 1/4" NPT PORTS STANDARD

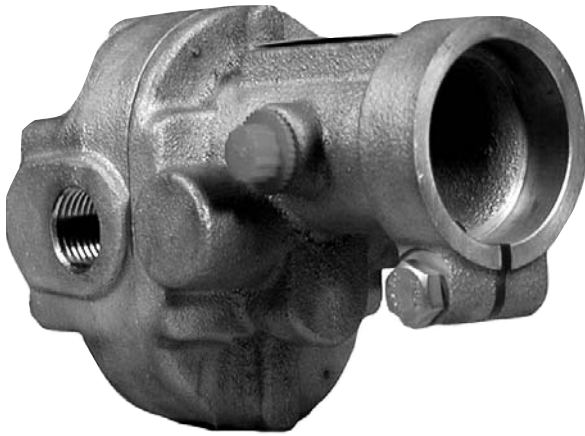

| Pump | Description |
|---------|---|
| N999 | Standard pump with 1/4" ports |
| N999R | Pump with 1/4" ports & relief valve |
| N999S5 | Pump with Viton(R)* lip seal |
| N999RS5 | Pump with Viton(R)* lip seal & relief valve |

FEATURES

- Compact design eases installation and use in limited space areas.
- Construction is bronze and stainless steel wetted components.
- Close tolerance design allows for consistent performance.
- Bronze spur gears

GENERAL DESCRIPTION

Pump housings and gears are made of top quality bronze, shafts are 303 stainless steel. Bearings are designed of high performance carbon-graphite material selected for wear resistance and long service life.

Gear pumps are positive displacement pumps. Each shaft revolution displaces a definite amount of liquid relatively unaffected by the back pressure in the discharge line. Shaft speed and flow are directly proportional. Recommended pressure limits are 100 PSI for water and non-lubricants, 150 PSI for oil and other lubricants. The maximum shaft speed is 1750 RPM.

SHAFT SEALS

Close coupled gear pumps are normally supplied with a Buna N lip seal. A lip seal made of Viton(R)* is available as an option. For a Viton(R)* Seal, add S5 to the pump model number.

LIQUIDS AND TEMPERATURE

These pumps are suitable for all liquids that are compatible with bronze. Most common liquids are water, oil, and mild chemicals in the pH range of 4 to 11. Viscous liquids require reduced shaft speeds of 1150 RPM or lower. (Consult factory.)

PERFORMANCE

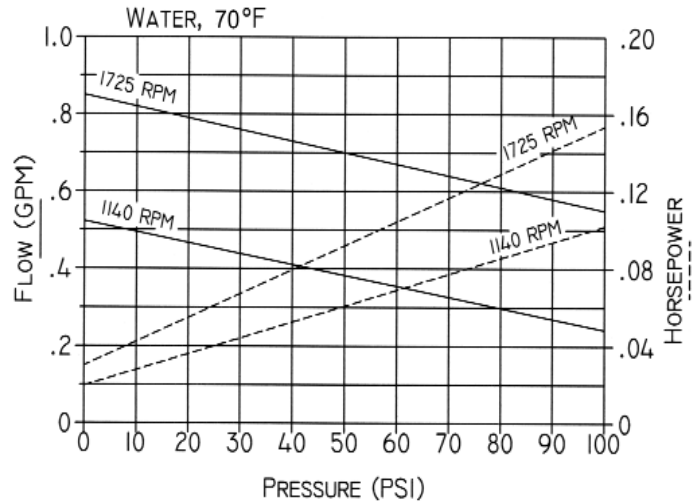

Liquids containing solids, abrasives, powders, or paint pigments are definitely not recommended for gear pumps. If abrasives are unavoidable, use a very low shaft speed.

The recommended liquid temperature range is from 32° F to 140° F for best pump life. If more extreme temperature conditions exist, factory should be consulted. Freezing of water-filled pumps can cause damage and must be avoided. Oils at low temperatures are very viscous requiring a lower speed or extra power.

SUCTION LIFT

As a general rule, the suction lift should be kept at an absolute minimum by placing the pump as close to the liquid source as possible. A gear pump in new condition can lift 20 feet of water in the suction line. A foot valve (preferably with built-in strainer) is recommended at the beginning of the suction line. For a first start-up, the pump should be primed to avoid dry running. Minimum size of the suction pipe is the size of the pump inlet port. For longer suction lines (over 3 feet) or for viscous liquids, the pipe should be at least one size or two sizes larger than the pump inlet port.

OPTIONAL RELIEF VALVE

If the discharge line contains any throttling devices such as a shut-off valve, a spray nozzle or other restrictive device, it is necessary to have a relief valve in the system which returns the liquid to the suction side or to the tank. The relief valve is also available as part of the pump itself (R-model pumps). However, built-in relief valves are only good for intermittent service. If used continuously, the pump will over-heat. A built-in relief valve is strictly a safety device against overpressure. It will not work successfully as a pressure or flow control device. For this purpose a separate relief valve in the pressure line must be used.

Unless otherwise specified, the pump motor unit is supplied by the factory for shaft rotation counterclockwise from shaft end. Reversing motor will reverse "in and "out" ports and also requires changing relief valve location. The relief valve is always on the inlet side of this pump series. The factory pressure setting is 50 PSIG. To increase pressure, turn the relief valve adjusting screw in a clockwise direction.

BRONZE CLOSE COUPLED ROTARY GEAR PUMPS



EXPLODED VIEW AND PARTS LIST

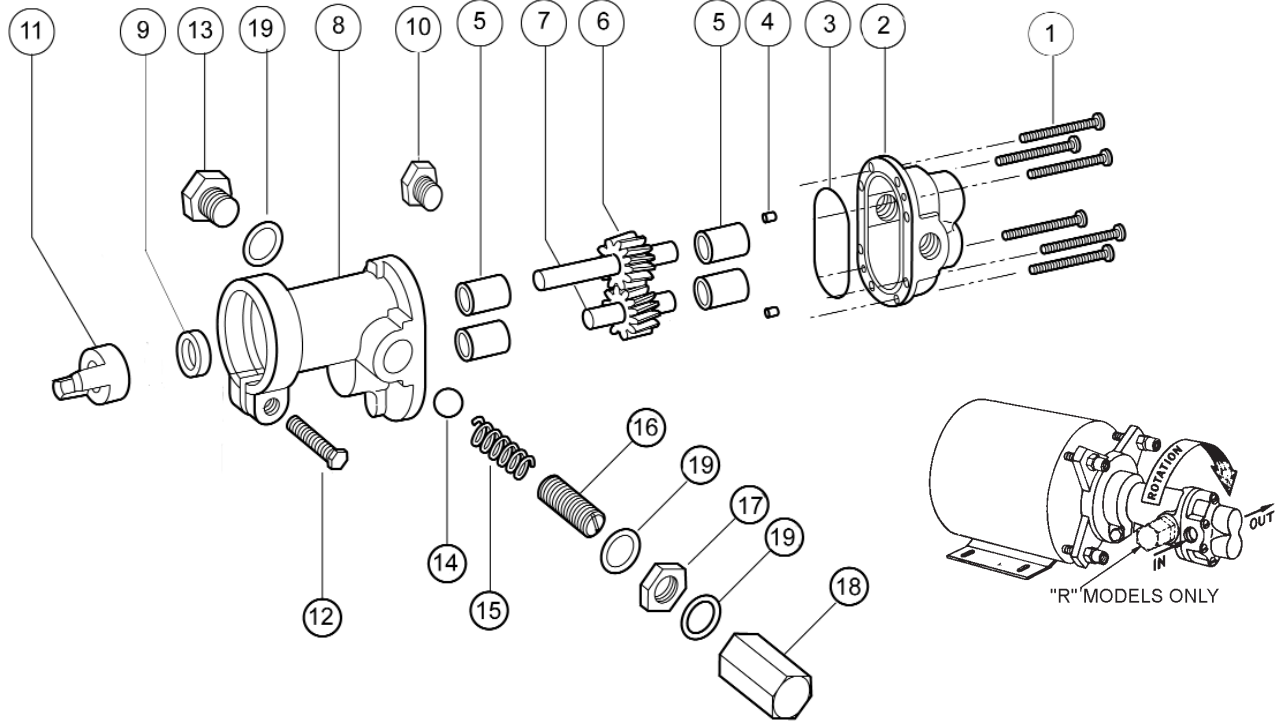

| Pump No. | 1 | 2 | 3 ² | 4 | 5 ² | 6 ² | 7 ² | 8 | 9 ^{1,2} | 10 | 11 | 12 | 13 | 14 | 15 | 16 | 17 | 18 | 19 |
|----------|---------|----------|----------------|-----------|----------------|------------------|-----------------|----------|------------------|----------|----------|---------|----------|---------|---------|------------|---------|------------|--------------|
| | Screw | Body | O-Ring | Dowel Pin | Bearing | Drive Gear Assy. | Idle Gear Assy. | Cover | Lip Seal | Cap Plug | Coupling | Screw | Plug Nut | Ball | Spring | Adj. Screw | Locknut | Bypass Nut | Fiber Washer |
| | 6 Req'd | 1 Req'd | 1 Req'd | 2 Req'd | 1 Req'd | 1 Req'd | 1 Req'd | 1 Req'd | 1 Req'd | 1 Req'd | 1 Req'd | 1 Req'd | 1 Req'd | 1 Req'd | 1 Req'd | 1 Req'd | 1 Req'd | 1 Req'd | 3 Req'd |
| N999 | 5506 | 9302NB5N | 9797-033 | 8885 | 5024 | 32198 | 32199 | 9303NN2N | 5007 | 9346 | 5604 | 5595 | --- | --- | --- | --- | --- | --- | --- |
| N999R | 5506 | 9302NB5N | 9797-033 | 8885 | 5024 | 32198 | 32199 | 9303NN2B | 5007 | 9346 | 5604 | 5595 | 1838 | 5803 | 1840 | 5237 | 5240 | 5239 | 6533 |

¹Seal # 5007 is Standard Buna N, # 7580 is Viton(R)*-Teflon(R)*

²Repair Kit contains items 3, 5, 6, 7 & 9. Repair Kit for N999(R) is #10873.

VARIATIONS

| Pump No. | g ^{1,2} | |
|----------|------------------|-------------------------|
| | Lip Seal | Repair Kit ² |
| N999S5 | 7580 | 12109 |
| N999RS5 | 7580 | 12109 |

*Viton® or equivalent FKM will be used. Viton® is a registered trademark of DuPont Dow Elastomers.

*Teflon® or equivalent PTFE will be used. Teflon® is a registered trademark of DuPont.

DIMENSIONS

