

DUCTILE IRON CLOSE COUPLED ROTARY GEAR PUMPS

**MODEL
C992
SERIES**



MODEL C992 - 1/2" NPT PORTS STANDARD



FEATURES

- Ductile Iron Construction
- Stainless Steel Shafts
- Ferrous Gears (Optional 416 Stainless Gears)
- Buna Mechanical Seal (Optional Viton Mechanical Seal)
- Process lubricated carbon bearings
- O-ring cover seal for maximum leak protection
- Durable paint finish
- Easy Field Assembly to a variety of motor frames
- Compact dimensions

GENERAL DESCRIPTION

Tailored specifically for wear resistance and long life in lubricating fluid service. They are designed to handle a wide range of fluids at temperatures to 200°F, at pressures up to 150 psi, and at shaft speeds to 1750 RPM. Viscous liquids require reduced shaft speeds.

Standard Lubricating Fluid Service: Shafting is 303 stainless steel, gearing is ferrous (optional 416SS gears). Rugged ductile iron housings. High grade carbon-graphite bushing style bearings are used. The Standard Mechanical Shaft Steel is a stainless cased buna elastomer bellows and o-ring with carbon and ceramic wear faces. An optional Viton mechanical seal with carbon and ceramic wear faces is also available. Recommended liquid temperature range is 32°F to 200°F.

Product	Relief	Gear	Mech. Seal	Repair Kit
C992M3E5	no	ferrous	Buna	12259
C992RM3E5	yes	ferrous	Buna	
C992M3E1	no	ferrous	Viton	12258
C992RM3E1	yes	ferrous	Viton	
C992M5E5	no	416 SS	Buna	12254
C992RM5E5	yes	416 SS	Buna	
C992M5E1	no	416 SS	Viton	12249
C992RM5E1	yes	416 SS	Viton	

Non Lubricating or High Temp Service: consult factory

As with all external gear rotary pumps which operate based upon close running clearances, the presence of solid particles and abrasives can lead to premature wear and damage. Use suction screens or start-up strainers when necessary.

PERFORMANCE

Water 70°F

1725 RPM

PSI	GPM	HP Req'd	HP Motor
0	4.3	0.12	1/3
20	4.0	0.18	1/3
40	3.8	0.27	1/3
60	3.7	0.36	1/3
80	3.5	0.46	1/2
100	3.4	0.56	1/2
125	3.2	0.69	3/4
150	3.1	0.83	1

1140 RPM

PSI	GPM	HP Req'd	HP Motor
0	2.8	0.06	1/3
20	2.5	0.11	1/3
40	2.4	0.17	1/3
60	2.2	0.24	1/3
80	2.0	0.3	1/3
100	1.9	0.39	1/2
125	1.7	0.47	1/2
150	1.6	0.57	1/2

SUCTION LIFT

Whenever possible, place the pump at an elevation below the liquid source. However since these positive displacement external gear pumps will generate 20" HG lift, this is not a requirement. As a general rule, place the pump as close to the liquid source as possible. For a first start-up, the pump should be primed to avoid dry running. Minimum size of the suction pipe is the size of the pump inlet port. For longer suction lines (over 3 feet), the pipe size should be at least one size or two sizes larger than the pump inlet port.

DRIVE ARRANGEMENT

These close-coupled pumps mount directly to a full range of NEMA and IEC C-face motors by means of a suitable adapter bracket. The clamp style cover also allows adapterless close coupling to modified 48 Frame 1/3rd and 1/2 HP motors. The pump drive shaft is connected to the motor shaft by a flexible coupling. Complete pump and motor units are available.

Gear Material	
Code	Gear Material
3	Ferrous
5	416 Stainless Steel

Shaft Material / Seal Option					
Code	Seal Style	Seal Materials			
		Rotary		Stationary	
		Face	Elastomer	Face	O-Ring
1	Elastomer Bellows	Carbon	VITON	Ceramic	VITON
5	Elastomer Bellows	Carbon	Buna	Ceramic	Buna

Mounted Close Coupled Adapter	
Code	Option
M	48 Frame
N	56 Frame
P	S56 Frame
Q	56C Frame
F	IEC 71 Frame
Blank	Adapterless

for Factory supplied pump and motor combinations

Additional Options	
Code	Option
BLANK	standard port size (by default)
E	BSPT Ports

Mounted Motor Codes (samples)	
Code	Option
F41	
N26	see motor listing for wide selection range
J16	

C992 M3 E5

**MODEL
C992
SERIES**

**DUCTILE IRON CLOSE COUPLED
ROTARY GEAR PUMPS**



EXPLODED VIEW AND PARTS LIST

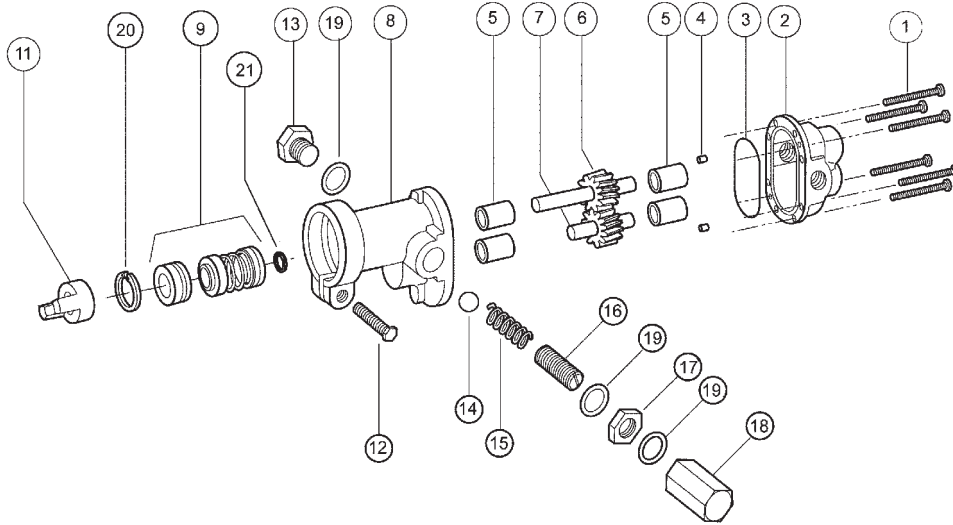

	1	2	3	4	5	6	7	8	9	11	12	13	14	15	16	17	18	19	20	21	Repair Kit	
	Screw	Body	O-Ring	Dowel Pin	Bearings	Drive Gear Assy	Idle Gear Assy	Cover Bracket	Seal	Coupling Half	Screw	Plug Nut	Ball	Spring	Adj. Screw	Lock Nut	Bypass Nut	Fiber Washer	Ret. Ring	Ret. Ring		
Pump No.	Qty. 6.00	Qty. 1.00	Qty. 1.00	Qty. 2.00	Qty. 4.00	Qty. 1.00	Qty. 1.00	Qty. 1.00	Qty. 1.00	Qty. 1.00	Qty. 1.00	Qty. 1.00	Qty. 1.00	Qty. 1.00	Qty. 1.00	Qty. 1.00	Qty. 1.00	Qty. 1.00	Qty. 3.00	Qty. 1.00	Qty. 1.00	
C992M5E1	7733	9307UDZN	9797-038	8885	5024	33112	33119	9309UN4N	32585	5604	5595	N/A	N/A	N/A	N/A	N/A	N/A	N/A	N/A	7639	5373	12249
C992RM5E1	7733	9307UDZN	9797-038	8885	5024	33112	33119	9309UN4B	32585	5604	5595	1838	5803	6302	5237	5240	5239	6533	7639	5373	12249	
C992M5E5	7733	9307UDZN	9797-038	8885	5024	33112	33119	9309UN4N	32584	5604	5595	N/A	N/A	N/A	N/A	N/A	N/A	N/A	N/A	7639	5373	12254
C992RM5E5	7733	9307UDZN	9797-038	8885	5024	33112	33119	9309UN4B	32584	5604	5595	1838	5803	6302	5237	5240	5239	6533	7639	5373	12254	
C992M3E1	7733	9307UDZN	9797-038	8885	5024	33134	33135	9309UN4N	32585	5604	5595	N/A	N/A	N/A	N/A	N/A	N/A	N/A	N/A	7639	5373	12258
C992RM3E1	7733	9307UDZN	9797-038	8885	5024	33134	33135	9309UN4B	32585	5604	5595	1838	5803	6302	5237	5240	5239	6533	7639	5373	12258	
C992M3E5	7733	9307UDZN	9797-038	8885	5024	33134	33135	9309UN4N	32584	5604	5595	N/A	N/A	N/A	N/A	N/A	N/A	N/A	N/A	7639	5373	12259
C992RM3E5	7733	9307UDZN	9797-038	8885	5024	33134	33135	9309UN4B	32584	5604	5595	1838	5803	6302	5237	5240	5239	6533	7639	5373	12259	

Repair Kits contain items 3, 5, 6, 7, 9, 20 & 21.

ROTATION AND RELIEF VALVE

(CONTINUED FROM FRONT PAGE) These pumps are bidirectional. The standard pump motor unit is set up for normal rotation (clockwise when viewing the pump from the shaft end). Reversing the motor rotation will reverse the "in" and "out" ports and also requires changing the relief valve location.

C992R is equipped with an integrated relief valve set up for internal bypassing. The relief valve must always be located on the discharge side of the pump. This relief valve is not intended to be a metering or flow control device. Its purpose is to function as a discharge pressure relief to guard against intermittent down stream system restrictions. Overheating can occur within 5 to 10 minutes if the discharge line is completely shut off. The pressure relief setting is not set at the factory. To increase pressure, turn the relief valve adjusting screw in a clockwise direction.

DIMENSIONS

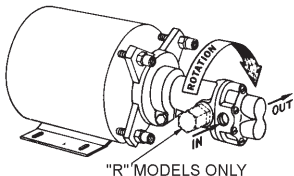
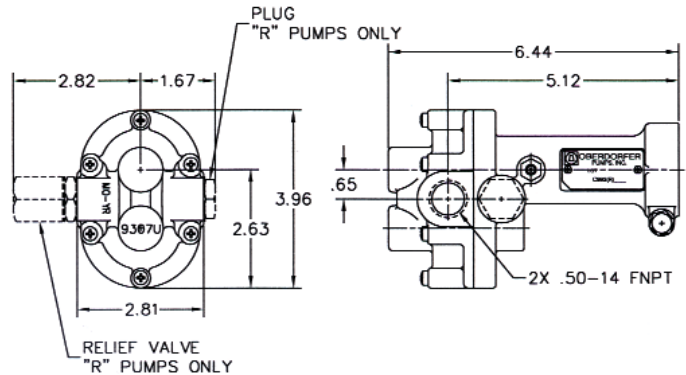

Adapter Kit	Kit Number	Description
M	10562	48 Frame
N	10816	56 Frame
P	11722	S56 Frame
Q	11331	56C Frame
F	11332	IEC71
----	----	Adapterless-Modified 48

Viton® or an equivalent fluoroelastomer may be used. Viton® is a registered trademark of DuPont Dow Elastomers. Specifications are subject to change without notice.