

## T51 SERIES

---

HORIZONTAL CLOSE COUPLED PUMPS  
VERTICAL FLANGE MOUNTED CLOSE COUPLED PUMPS  
FLEXIBLE COUPLED PUMPS

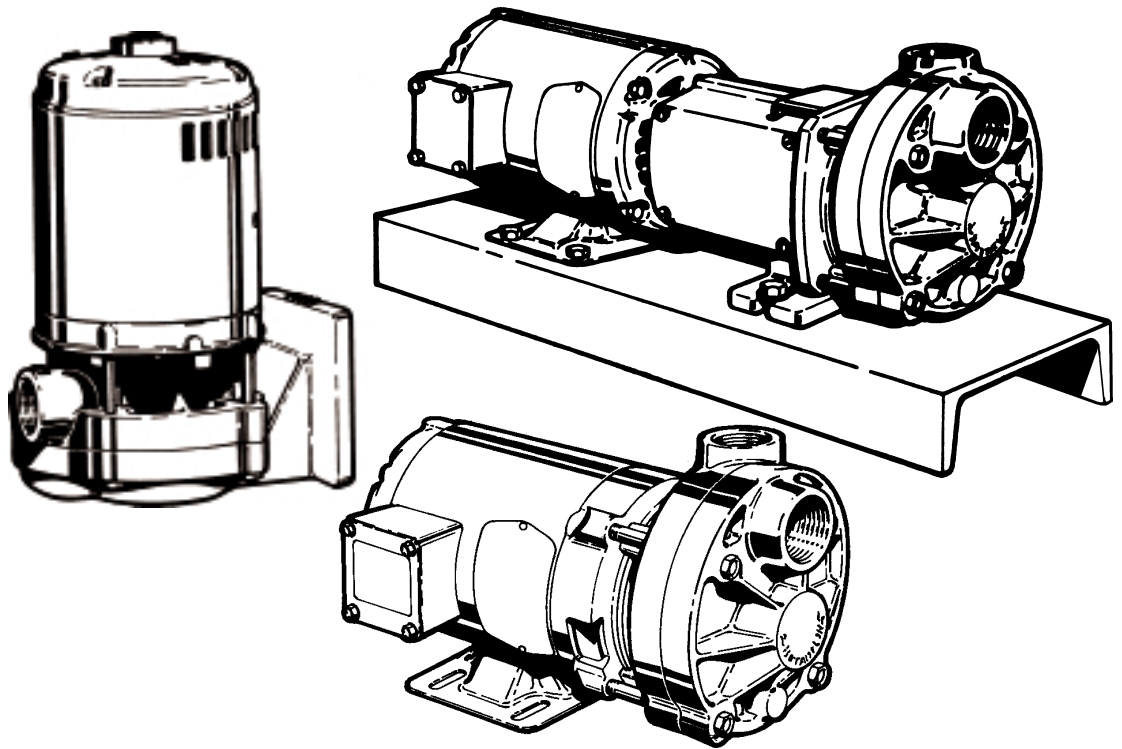

**MTH PUMPS**

401 West Main Street • Plano, IL 60545-1436  
Phone: 630-552-4115 • Fax: 630-552-3688

## T51 SERIES

# 1. General Instructions

HORIZONTAL CLOSE COUPLED PUMPS  
VERTICAL FLANGE MOUNTED CLOSE COUPLED PUMPS  
FLEXIBLE COUPLED PUMPS

- A. Inspection of Equipment
- B. Storage
- C. Placing Stored Pumps Into Service
- D. Application Considerations
- E. Recommended Spare Parts

When properly installed and given reasonable care and maintenance, regenerative turbine pumps should operate satisfactorily for many years. They do not, however, have a service life equal to that of low head centrifugal pumps, which are not subjected to the typical differential pressures produced by the regenerative turbine pump. Because of the high differential pressures expected in a regenerative turbine pump, close running clearances are used to reduce internal losses. Abrasive particles, even microscopic ones, in high enough concentrations, can open up the close clearances between internal components. For critical services it is recommended that you keep an identical pump for stand-by use.

## 1A Inspection of Equipment

Immediately upon receipt of the shipment, inspect the equipment for damage or missing components. Check the shipping manifest and report any damage or shortage to the Transportation Company's local agent. Inspect the crate and any wrapping material before discarding. Parts or accessories are sometimes wrapped individually or fastened to the skid. Put the instructions that came with the shipment in a safe place where they will be available to those who will be using them for installation and service.

## 1B Storage

If the pump is to be stored before use, it should be inspected as described in 1A, resealed and stored in a dry location. Standard

shipping containers are not suitable for outdoor storage. In some areas, it may be necessary to cover the pump's exterior surface with oil or other rust inhibiting coating. For storage beyond 30 days, Ethylene Glycol or another protective fluid must be used inside the pump. Fluids used in the pump should be selected for compatibility with the pump's materials. This is very important when optional seal and gasket materials have been used. Protective caps on the inlet and outlet must also be used. Caps alone are not sufficient protection.

## 1C Placing Stored Pumps Into Service

Special care must be taken when placing stored pumps into service. First clean the outside and flush out the inside. Try to turn the pump using the coupling. If the impellers do not break loose immediately, fill the pump with water and try again in a few hours. If this doesn't work, refer to the disassembly/reassembly instructions in Section 4. Loosen the thru-bolts clamping the assembly together, three full turns, no more. Fill the pump with water. Apply torque, 50 foot pounds maximum, to the coupling. On close coupled units, access to the shaft is between the pump and motor. A vise grip or other plier type gripping device may be used directly on the shaft or lock collar, depending on the motor model used. Applying torque to the motor fan blades is not recommended. The pump should turn before the 50 foot pounds is reached. Continue turning the pump while tightening the thru-bolts to their original positions.

## 1D Application Considerations

### 1D1 Electrical Wiring

All electrical equipment and wiring should conform to local and National Electrical Codes. Use the motor manufacturer's instructions for connecting the motor. Note the correct rotation and wiring dia-

grams on the assembly. Make sure the motor rotation and speed matches that required for the pump.

## 1D2 Construction Materials

While it is reasonable to assume that good judgement has been used in selecting all the materials in the pump for compatibility with process fluids, actual conditions sometimes vary from original specifications. Also, typical material selection charts do not consider all the temperature, pressure, and fluid variables. The customer's engineer should be consulted for final judgement on the best materials for critical process applications.

## 1D3 Valves

The first valve to be considered for a regenerative turbine pumping system might be a pressure relief valve. Because this type of pump has a horsepower requirement similar to that of a positive displacement pump (constantly rising hp along with pressure increases) a relief valve can be effectively used to limit horsepower. This is helpful when a non-overloading motor is specified. It can be of critical importance if the system flow rate can vary widely. There are almost no circumstances where a flow modulating valve will work successfully in a regenerative turbine pumping system. The steep pumping characteristic produces very large pressure changes with small variations in flow rate. As a result, the modulating flow from the valve introduces sharp pressure shock waves that shorten pump life and may cause damage in other pieces of equipment in the system. If a shutoff valve is necessary in the suction line, use a gate, ball, butterfly, or other full port valve. Globe or other flow restricting valves can in some cases reduce pump flow or increase chances of cavitation. A swing check valve is recommended in the suction line even when the pump inlet is even slightly higher than the fluid

source. It should be the same size as the pump inlet or sized based on reasonable fluid friction losses. A foot valve is recommended when lifting fluid from a sump. This will save wear and tear on any pump, even those equipped with self priming capability.

A Y-Strainer is recommended immediately ahead of the pump on any newly constructed system. This is advisable due to the probability that foreign material large enough to damage pump clearances may remain even though the piping has been flushed.

Valves in the outlet piping of a regenerative turbine pump should always be open as far as possible when the pump is started. This will reduce the start-up load on the pump and motor. Never start the pump with the discharge valve closed.

The inlet valving should be open when starting any pumping system. Without some fluid in the pump, it can gall and lock up impellers. Violent pump failure will result from continued operation with the inlet valve closed.

#### 1D4 Priming

Regardless of whether self-priming equipment is used or not, always fill the pump and vent it of air before starting for best seal and pump life. Under most circumstances, regenerative turbine pumps can be made to self-prime as long as a small amount of fluid can be recirculated through the impeller and the fluid doesn't heat up noticeably.

#### 1D5 NPSH (Net Positive Suction Head)

The NPSH required varies with every size and capacity of pump. The NPSH required by your unit can be obtained from the performance curves or from your MTH representative.

If the NPSH available is not equal to or greater than that required by the pump, it must be increased or a different pump selected. The usual method for increasing NPSH is to raise the static head on the pump inlet,  $H_s$ .

By definition, NPSH means: "net positive suction head" above the vapor pressure of the pumped liquid available at the centerline of the pump. It should always be given in feet of pumped liquid. The NPSH is actually a measurement of the amount of energy available in the pumped liquid to produce the required absolute entrance velocity in the pump. If a pump requires more energy (or NPSH) than is available at a given capacity, the pressure at the inlet will fall below the vapor pressure of the pumped liquid and loss of performance will result.

$P_s$  = Pressure in the suction vessel in PSIA.

$P_{vp}$  = Vapor pressure of the pumped fluid in PSIA.

$H_s$  = Static height of the pumped fluid above (+) or below (-) the centerline of the pump in feet.

$H_f$  = All friction losses from the vessel to the pump in feet.

$$NPSH = 2.31 \left( \frac{P_s - P_{vp}}{\text{sp. gr.}} \right) + H_s - H_f$$

For boiling liquids,  $P_s$  and  $P_{vp}$  are equal. This item then becomes zero and can be omitted from the equation.

#### 1D6 Noise

Regenerative turbine pumps typically produce a high pitched whine that increases in intensity as the differential pressure produced in the pump increases. While high frequency sound is attenuated more easily than lower frequencies, piping structures and the fluids in them readily transmit noise. Motors, bearings, and other rotating components add to the noise and sometimes create objectionable harmonics. Careful pump installation can alleviate noise problems. Proper alignment of the pump and driver is essential. Adequate supports for the inlet and discharge piping is equally important. A degree of noise reduction may be obtained when the pumping unit is supported free of building structures by the use of vibration isolators and flexible piping and conduit connec-

tions. Elastomer type couplings are the best choice to separate motor noises from the fluid and piping structure.

#### 1D7 Freezing

When ambient temperatures drop below the freezing point of the fluid in a pump, consideration should be given to heating, insulating, or draining the pump. If you choose to drain the pump, and it will only be for a short period, first remove the drain plugs, and then drain the inlet and outlet lines. Carefully blow out the pump with compressed air to clear all internal cavities of fluid.

#### 1E Recommended Spare Parts

FOR CRITICAL SERVICES - a duplex installation, with two identical pumping units in parallel, is the safest and many times the most cost effective choice.

FOR IMPORTANT SERVICES - a standby pump, ready for installation is advised. Special pricing and new pump warranty is offered for factory rebuilding. Turn around time can be as short as one or two days for standard models.

FOR ROUTINE MAINTENANCE - only the mechanical seals and a complete set of "O" ring gaskets are recommended. Should additional components show wear, they are available from stock at the factory.

FOR SERVICING A PUMP THAT DOES NOT PRODUCE RATED HEAD - mechanical seals, "O" ring gaskets, impeller, motor bracket, and cover.

FOR REBUILDING A PUMP - all the components required for servicing, plus bearings, shaft, and drive keys for flexible coupled pumps, should be obtained. A factory rebuild should be considered whenever your disassembly indicates rebuilding is necessary as this is usually more economical. The factory recommendation for spare parts are all of those needed for rebuilding a pump and are shown on the exploded view drawings for each individual type of pump.

## T51 SERIES

## 2. Installation

### FLEXIBLE COUPLED PUMPS CLOSE COUPLED PUMPS

- A. Location
- B. Foundation
- C. Leveling
- D. Alignment
- E. Piping
- F. Typical Installation

In order to insure that pumping equipment is installed properly and to obtain reliable pump operation, it is recommended that only experienced, qualified erecting engineers undertake this task. Read the instructions thoroughly before beginning.

#### 2A Location

The first consideration for locating a pump is elevation. The lowest possible elevation using the shortest possible suction piping is usually the best. Questions regarding possible locations should be resolved by making inlet head calculations including all friction losses. The one producing the highest inlet pressure should be selected. One reason for this precaution is that, the greater the inlet pressure, the less likelihood of NPSH problems. Also a flooded suction is particularly helpful on start-up when the seals or the entire pump can be ruined because it is not properly primed and purged of air.

A dry, easily accessible location is also important. Allow ample clearance around the unit for free air circulation. If a dry location is not available, the pump can be mounted on a foundation, above the floor. Specify motor enclosure, pump materials, or coatings to suit the worst conditions expected.

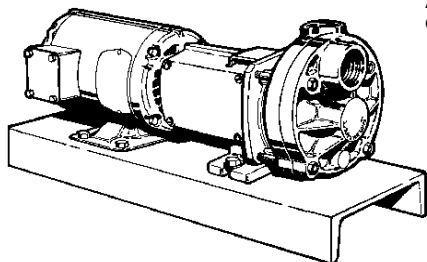

Figure 2-1

Place the pump so that it can be easily inspected and serviced during operation. Sufficient head room should be provided, particularly when lifting devices will be used for heavier assemblies.

#### 2B Foundation

Baseplates alone are not rigid enough to maintain alignment of the unit. The pump foundation is used as a support for the baseplate to maintain alignment of the unit. If the baseplate is to be grouted to the foundation, it is only necessary to embed the edges. It is unnecessary to completely fill under the baseplate. DO NOT grout the unit to the foundation until it has been properly aligned.

The foundation must be a permanent rigid installation of concrete or other material of sufficient mass to absorb all normal vibrations. Locate the foundation bolts using a layout or template in relation to the suction and discharge piping. If concrete is being used, foundation bolts of the specified size can be enclosed in a pipe sleeve two to three diameters larger than the bolts to compensate for minor variations in alignment.

Close coupled pumps can be mounted on a steel base prior to installation or mounted directly to the foundation. Place shims under one or more of the motor feet so that strain and distortion will not result when the mounting bolts are tightened.

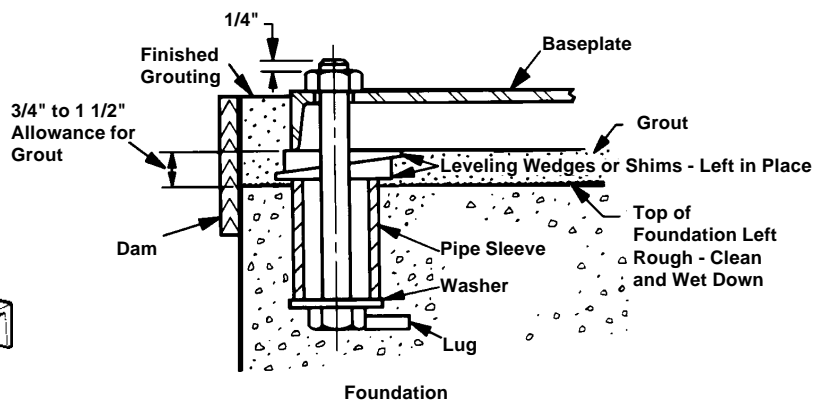

Figure 2-2

#### 2C Leveling (Flexible Coupled Pumps Only, Refer to Figure 2-1)

If the unit is received with the pump and motor mounted on the baseplate:

1. Place the unit in position.
2. Disconnect the coupling halves. Do not reconnect until all alignment procedures have been completed.
3. Support the baseplate on metal shims or wedges having a small taper. (Refer to Figure 2-2)
  - a. Place shims close to the foundation bolts. (Refer to Figure 2-3)
  - b. Also place shims close to where the greatest weight is located.
4. Check the baseplate for distortion:
  - a. Place a straightedge along the baseplate to determine if it is distorted.
  - b. Adjust the shims until the baseplate is not distorted.
5. Use a section of pipe to determine if the inlet and discharge openings are vertical and located properly.
6. Correct the positions, if necessary, by adjusting the shims.

## 2D Alignment

Although flexible coupled pumps are carefully aligned prior to crating and shipping, it is very likely that strains imposed during transit have altered the alignment. Complete the following steps after the unit has been placed on the foundation and leveled.

The standard coupling supplied by MTH Pumps has an elastomer member between two internal serrated flanges. They have smooth outsides of equal diameter. These surfaces are used for alignment procedures. To check the PARALLEL alignment: (Refer to Figure 2-4)

1. Place a straightedge across the two coupling flanges.
2. Measure the maximum offset (A), Figure 2-4, at various points around the periphery of the coupling. DO NOT rotate the coupling.
3. If the maximum offset exceeds the Parallel dimension in Chart 1 for your sleeve size, loosen the motor or pump and place thin metal shims under the motor or pump feet until the offset is corrected.
4. Torque down the motor or pump.
5. Recheck alignment.

To check the ANGULAR alignment: (Refer to Figure 2-5)

1. Using a micrometer or caliper, measure from the outside of one flange to the outside of the other at intervals around the periphery of the coupling. DO NOT rotate the coupling.
2. Determine the maximum (B) and minimum (C) dimensions.

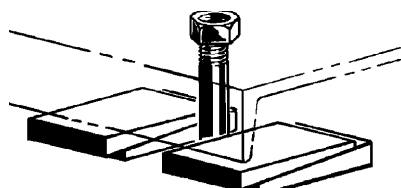

Figure 2-3

3. If the difference between the maximum and minimum exceeds the Angular dimension in Chart 1 for your sleeve size, loosen the motor or pump and place thin metal shims under the motor or pump feet until the misalignment is corrected.
4. Torque down the motor or pump.
5. Recheck the parallel alignment above.

### CHART 1

COUPLING TYPES JE, J, S			
MAX. RPM & ALLOWABLE MISALIGNMENT			
SLEEVE SIZE	MAXIMUM RPM	PARALLEL A	ANGULAR B-C
3	9200	.010	.035
4	7600	.010	.043
5	7600	.015	.056
6	6000	.015	.070

If the parallel or angular misalignment is great, this is an indication of baseplate distortion and must be corrected first, refer to 2C Leveling.

After all leveling and alignment operations have been completed, piping can begin. After the piping has been completed, refer to 2E1, Piping Alignment. Alignment of the unit must be rechecked to make certain that no piping strains are causing distortion. After approximately two weeks of operation, check the alignment again to make sure that temperature changes, piping strain, or foundation variations have not caused misalignment. If alignment has been maintained over this period, the pump and motor can be dowelled to the baseplate.

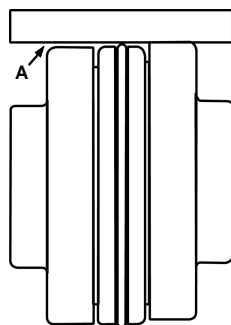

Figure 2-4

## 2E Piping

### 2E1 Alignment

It is important that all piping be lined up and not forced into place. It is recommended that you begin piping at the pump. If the lines are ended at the pump, particularly if the last piece is cut a little too short or long, the pump will be forced to meet the pipe and strain or distortion will result.

### 2E2 Piping Support

Never allow the pump to support piping. Other means such as pipe hangers and pipe supports should be used to carry piping to avoid misalignment and distortion. Consideration should be given to thermally induced expansion and contraction, particularly in long runs of straight pipe.

### 2E3 Piping Size

In general, outlet and especially inlet pipe sizes should be equal to or larger than those of the pump. This may not, however, be the final determining factor. Many things, including installation and operating costs are involved in the decision. Careful use of the pipe and fitting friction loss tables (as shown in the Hydraulic Institute manual), along with the appropriate pump performance curve, should be the basis for judgements.

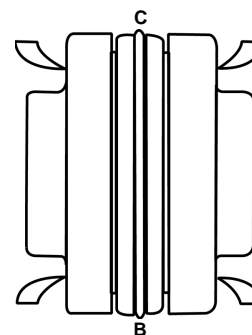

Figure 2-5

## T51 SERIES

# 3. Operation

## FLEXIBLE COUPLED PUMPS CLOSE COUPLED PUMPS

- A. Rotation
- B. Inlet and Outlet Locations
- C. Foreign Material
- D. Electrical
- E. Adjustments
- F. Cooling Water
- G. Priming
- H. Starting
- I. Stopping

### 3A Rotation

The standard direction of rotation for the pump is right handed, or clockwise, when looking at the motor end of the pump. A rotation arrow, refer to Figure 3-1, is located on the pump to indicate the correct direction of rotation.

Operating the pump in reverse will cause substantial performance variations and can damage the pump.

Always confirm correct motor rotation prior to connection of the coupling. If this is not possible, perform a final rotation check as follows:

1. Jog the motor briefly.
2. Observe rotation as the unit comes to a stop.
3. Rotation should be in the direction of the arrow.

If the motor operates in the wrong direction:

1. Interchange any two leads on a three phase motor.

2. On a single phase motor, change the leads as indicated on the connection box cover. Some single phase motors may not be reversible.

### 3B Inlet and Outlet Locations (Refer to Figure 3-1)

The pump inlet is located on the end farthest from the motor. The discharge or "outlet" can be on the top, side, or bottom depending on the model and construction of the pump. Normal discharge position is on top.

### 3C Foreign Material

All regenerative turbine pumps have close running clearances in order to maintain efficiency. Take extra precautions to insure that no foreign material larger than 25 microns or .001 inches is allowed to pass through the pump. Even particles of this size will damage the pump if allowed to circulate continuously. Regenerative turbine pumps are not designed for slurries.

Large particles, weld spatter, and other material found in new piping systems will bend the impeller vanes and can sometimes lock up the pump. If a new pump does not operate properly, the first thing to check for is damage from foreign material.

### 3D Electrical

It is important to be aware of and follow the appropriate local and national electrical codes. Do not make wiring alterations that can affect motor rotation without

reconfirming correct rotation. Select starter heaters and wiring for the maximum current the motor can use at full service factor loads. Regenerative turbine pumps will typically use extra power for a period until they run in. This can take three to four weeks depending on the duty cycle. During this period, impellers are finding their hydraulically balanced position.

### 3E Adjustments

No adjustments are required or advisable on new pumps, other than those required for installation. Because of the tight tolerances of regenerative turbine pumps, it is not uncommon for the pump to be difficult to turn over by hand after the internal parts have been allowed to dry out. New pumps from the factory are tested using rust inhibitors to help preclude this possibility. On site system flushing may remove these inhibitors and subject the pump to the risk of lock up, if it is allowed to dry out. In this case, do the following:

1. Fill the pump with fluid (wait 2 hours).
2. Insert 5/32" Allen wrench into lock collar setscrew and rotate shaft, using the Allen wrench as a handle. (DO NOT LOOSEN SETSCREW)
3. Remove the Allen wrench.
4. Jog the pump momentarily using the on/off buttons if so equipped.
5. This should "break" the impeller loose without damage, unless foreign material has entered the pump.

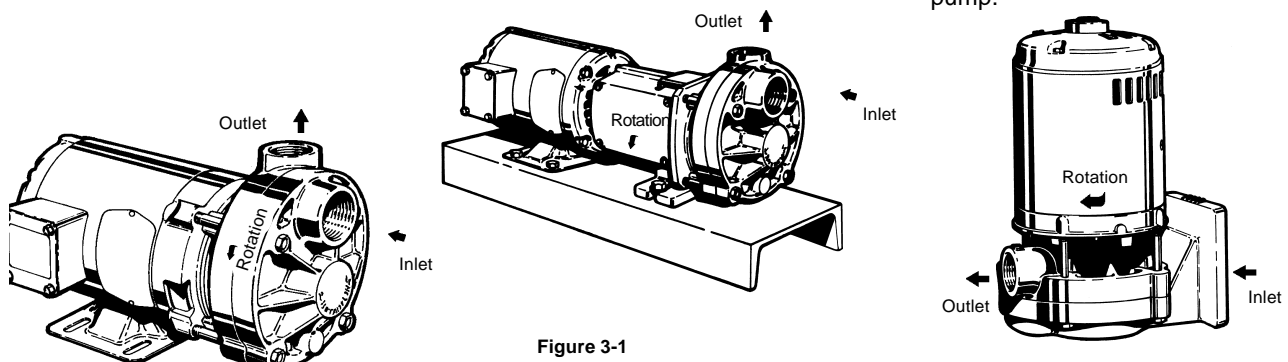

Figure 3-1

This procedure will flush residue from the close fitting impeller surfaces. If not immediately successful, refer to Section 1, 1C Placing Stored Pumps Into Service. Because of the large areas of close fitting surfaces inside these pumps, it takes only microscopic residue to produce substantial resistance to rotation. Once loosened, this material is quickly dispersed and the impellers find their hydraulic center. If these procedures are followed carefully, no damage will result from "breaking loose" the impeller.

### 3F Cooling Water

When the pump is used to transfer hot fluids, consideration should be given to cooling the seals and/or selecting materials that will give satisfactory seal life. The actual temperature at the seal faces, the most critical area, will always exceed the surrounding fluid temperature. If seal flushing lines have not been installed, heat can build up on the seal faces to a degree that may destroy the fluid film necessary to prevent rapid wear. In some cases it is necessary to cool the seal flushing fluid. Refer to the seal manufacturers charts for guidance, or to selection data in the MTH catalog, any time fluids can reach or exceed their boiling point.

### 3G Priming

Pumps should not be operated unless they are completely filled with liquid. Damage to parts of the pump that depend on liquid for their lubrication can occur. Impellers can seize quickly when a pump is run dry. Without lubrication, seal faces can be damaged from heat buildup. Pumps can be easily primed with a vacuum pump. An ejector or liquid ring vacuum pump is recommended because they are not damaged if liquid enters them. Connect the vacuum line to the discharge side of the pump, either in the discharge opening or the drain tap. A foot valve is not necessary when this kind of device is used. When a vacuum pump is not practical, a foot valve in the suction inlet can be used to prevent liquid from running out. The pump and suction line can

then be filled completely from an outside source. A vent opening will be necessary during filling to let air escape. A tight foot valve will keep the pump constantly primed so that automatic operation is possible. The valve should be inspected regularly to see that it does not develop leaks, allowing the pump to run dry. Optional self-priming casings are available for MTH pumps allowing priming when a vacuum pump or foot valve is not practical. Refer to specific literature for details.

There are four components to the self primer:

1. A check valve - necessary to maintain a vacuum in the suction line as surging occurs in the pump.
2. An air eliminator - used on the discharge side of the pump to separate air from liquid so the liquid can be used again as air is carried through the pump.
3. A recirculating line - carries liquid from the air eliminator to the suction.
4. A fluid chamber - used on the inlet side to provide a supply of fluid to speed up priming.

Small suction lines are desirable to minimize priming time.

Using the self priming casing, it is only necessary to:

1. Open the plugs in both the inlet and discharge chambers.
2. Pour fluid in one until both are full.
3. Tighten both plugs.
4. Turn on the pump.

Priming time depends on lift, volume of air in the suction line, and the size of the regenerative turbine pump used. If priming time is long and the pump becomes warm, refill the priming chambers with fresh liquid. Most turbine pumps will pump twenty-six to twenty-eight inches of mercury vacuum with cold water in the pump, but have very little capacity and therefore are not

practical at lifts over twenty-two feet.

The best way to prime a pump and keep it primed is to use a flooded suction. While this is not always practical, it does provide a number of advantages. The likelihood of pump damage from dry running is eliminated. Suction lines may be large, reducing line losses and minimizing the potential of cavitation damage. There are no check valves or priming devices to fail or require maintenance. Whenever possible, design pumping systems with a flooded suction.

### 3H Starting

Before starting a pump for the first time, be sure that all the preceding operations have been carried out. Proper rotation, priming, and a free turning pump are most important.

1. Start the pump with the minimum possible line restriction.
2. Open discharge valves before pressing the starter.
3. Start the pump and let the system clear of air.
4. Listen for foreign material being carried through the pump.
5. Slowly close necessary valves or otherwise place the pump into service.
6. Listen for indications of undue load or other sounds indicating problems.
7. Use a clip-on ammeter to check for a steady load after approximately fifteen minutes of operation.

### 3I Stopping

It is best to stop the pump with the least discharge head possible both for minimizing strain on components, and to be in low power mode in anticipation of restarting. If the pump will be down for more than a few weeks it is advisable to drain it. Follow the instructions for long term storage, Section 1, 1B Storage. After any prolonged stoppage, turn the pump over by hand before restarting, to be sure it is free.

## T51 SERIES

# 4. Service

## PUMP ENDS

- A. Preliminary
- B. Disassembly C3 & P3
- C. Disassembly C15 & P15
- D. Inspection of Components
- E. Reassembly C3 & P3
- F. Reassembly C15 & P15
- G. Testing and Final Adjustments

### 4A Preliminary

Before attempting any service on the pump or motor, disconnect the electrical power to the pump motor. If the pump and motor are to be removed as a unit, note the wiring configuration. Use colored or numbered tape to mark the wire connections of the motor and power source, for reconnection. If the pump is being used to transfer hot liquid, let the pump and liquid cool before starting disassembly.

1. Disconnect the inlet and outlet piping before unbolting the pump and motor. If the pipes are corroded, use penetrating oil on the threads to aid in removal.
2. Unbolt the motor from the base and remove the unit. All work on the unit should be performed on an elevated workbench whenever possible.

The disassembly and reassembly procedures are broken into four sections covering the following units:

- 4B — Disassembly of the C3 and P3 Units (3 hp and under)
- 4C — Disassembly of the C15 and P15 Units (5 hp and up)
- 4E — Reassembly of the C3 and P3 Units
- 4F — Reassembly of the C15 and P15 Units

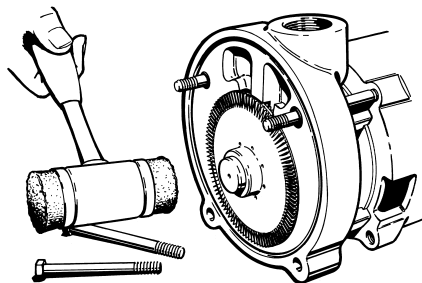

Figure 4-1

Exploded views of each unit, Figures 4-4, 4-5, 4-11, and 4-12, are provided for referencing the numbers in the following procedures, i.e. (#1), motor bracket.

### 4B Disassembly (C3 and P3)

The following tools and equipment are needed for disassembly of C3 and P3 units:

1. Soft plastic or wooden mallet.
2. Small ball peen hammer.
3. 9/16" wrench or socket.
4. 5/32" hex wrench.
5. Penetrating oil.
6. 1" wood dowel (Approx. 6" long).
7. Thin blade screwdriver.
8. Two large blade screwdrivers.
9. Cealube G or similar glycol base lubricant. (DO NOT use petroleum products.)

To disassemble the pump:

Refer to Figures 4-4 and 4-5 for reference to the numbered parts in the procedures below.

1. Remove all liquid from the pump. Air blown through the pump will remove the water quickly.
2. Remove the two (2) nuts (#20), and the two (2) 3/8" X 4" bolts (#19) from the cover (#2).
3. Remove the cover. In some cases light tapping with a plastic or wooden mallet on the outside diameter of the cover may be required to loosen it from the motor bracket. Care should be taken if a screwdriver is needed to pry between the cover and motor bracket. Damage to the "O" ring (#7) and/or impeller can result.

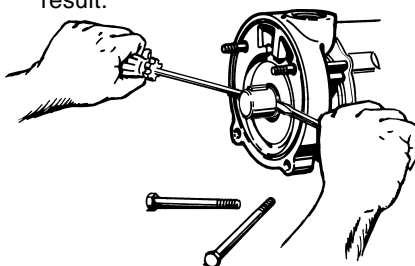

Figure 4-2

4. Remove the impeller (#11), refer to Figure 4-1. The impeller is a slip fit and, under normal conditions, can be removed by gently tapping on the end of the shaft sleeve with a mallet. Leave the impeller key (#23) in place. Striking the sleeve too hard could damage the seat or rotating element.
5. Using the 5/32" hex wrench, loosen the set screws (#15) in the locking collar (#14), located on the shaft sleeve between the motor bracket and the motor face. The collar should now be loose on the sleeve. Note the condition of the setscrew in the collar and replace if necessary.
6. Remove the shaft sleeve (#17). The sleeve is a keyed fit and is removed using two large screwdrivers, Refer to Figure 4-2.

- a. Insert the blades of the screwdrivers between the springholder on the rotating element and the shoulder of the shaft sleeve.
- b. Holding the screwdrivers at approximately 3 o'clock and 9 o'clock, push the handles in toward the motor body, using the motor bracket for leverage.

7. In some cases a rocking motion of the screwdrivers will be necessary to break the sleeve loose. Normally the rotating element will slide off with the sleeve. DO NOT attempt to remove the sleeve by rotating it. (Previous models have used a threaded shaft and different procedures are required in these cases.)

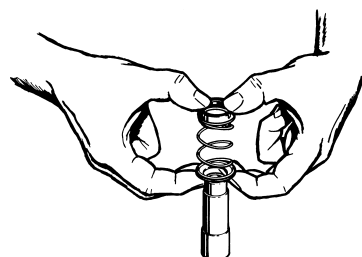

Figure 4-3



8. Remove the rotating element from the sleeve. Refer to Figure 4-3. The element normally adheres tightly to the sleeve and some force may be necessary to remove it. This is common and if care is taken, the element can be reassembled and reused. **It is recommended that a new rotating element be used for reassembly.** DO NOT attempt to remove the seal using a screwdriver or other sharp object. Extensive damage to the shaft, sleeve, or element could occur.

9. Before the motor bracket (#1) can be removed, the four (4) "O" rings (#8), located on the upper left and right studs must be removed.

- Gently tap on the back of the motor bracket, alternating between the left and right side, until the motor bracket moves approximately 1/4".
- Tap the motor bracket face to move it back to its original position.
- Remove the "O" rings by sliding them off the studs.
- Slide the motor bracket straight off. Do not attempt to remove the motor bracket without first removing the "O" rings (#8).

10. Remove the seat portion of the seal, Refer to Figure 4-6.

- Place the motor bracket face down on a flat surface.
- Look into the opening in the center of the bracket, you will see a portion of the seat.
- Insert the 1" dowel and, very gently, tap the seat until it drops out.
- Care must be taken with the seats. They are often a brittle material and are prone to breakage. **It is recommended that a new replacement seat be installed during reassembly.**

11. It is not necessary to remove the locking collar (#14) on the motor shaft unless motor repairs are

planned. Note the condition of the setscrew in the collar and replace if necessary. The two studs (#18) may also be left in the motor face.

#### 4C Disassembly (C15 and P15)

The following tools and equipment are needed for disassembly of C15 and P15 units:

- Soft plastic or wooden mallet.
- 9/16" wrench or socket.
- Two 10" or larger adjustable wrenches.
- Penetrating oil.
- 1" wood dowel (Approx. 6" long).
- Thin blade screwdriver.
- Two large blade screwdrivers.
- Cealube G or similar glycol base lubricant. (DO NOT use petroleum products.)

To disassemble the pump:

Refer to Figures 4-11 and 4-12 for reference to the numbered parts in the disassembly below.

- Remove all liquid from the pump.
- Remove the two (2) 3/8" nuts (#20), and the two (2) 3/8" X 4" bolts (#19) from the cover. (#2)
- Remove the cover. In some cases, light tapping with a plastic or wooden mallet on the outside diameter of the cover may be required to loosen it from the motor bracket. Care should be taken if a screwdriver is needed to pry between the cover and motor bracket. Damage to the "O" ring (#7) and/or impeller can result.
- Remove the impeller (#11), refer to Figure 4-7. The impeller is a slip fit and, under normal conditions, can be removed by gently tapping on the end of the shaft sleeve with a mallet. Leave the impeller key (#23) in

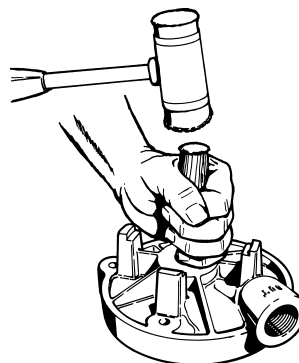

Figure 4-6

place. Striking the sleeve too hard could damage the seat or rotating element.

5. Remove the impeller drive hub, Refer to Figure 4-8. Two (2) adjustable wrenches are used to remove the impeller drive hub (#14).

- Adjust one wrench to fit over the sleeve and engage the impeller key. Adjust the second wrench to fit the impeller nut (#15).
- Holding both wrenches, turn the impeller nut counter-clockwise.
- After the impeller nut is removed, the impeller drive hub can be removed.
- The hub is keyed and can be removed using two large bladed screwdrivers.
- Insert the blades of the screwdrivers between the springholder on the rotating element and the shoulder of the hub.
- Holding the screwdrivers at approximately 3 o'clock and 9 o'clock, push the handles in toward the motor body, using the motor bracket for leverage. Refer to Figure 4-9. This procedure usually does not require excessive force. Care should be taken not to damage the hub or motor shaft.

6. Remove the rotating element from the shaft. The element normally adheres tightly to the motor shaft and some force may be necessary to remove it. This is common and if care is taken, the element can be reassembled and reused. **It is recommended that a new**

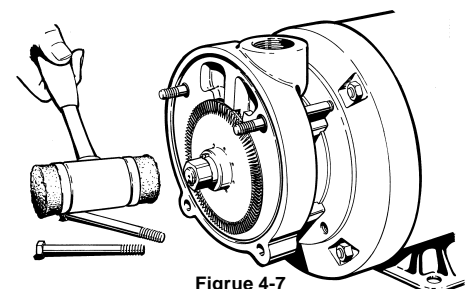

Figure 4-7

T51 SERIES

# 4. Service

rotating element be used for reassembly. DO NOT attempt to remove the seal using a screwdriver or other sharp object. Damage to the shaft or element can occur.

7. Before the motor bracket (#1) can be removed, the four (4) "O" rings (#8), located on the upper left and right studs must be removed.

a. Gently tap on the back of the motor bracket, alternating between the left and right side, until the motor bracket moves approximately 1/4".

b. Tap the motor bracket face to move it back to its original position.

c. Remove the "O" rings by sliding them off the studs.

d. Slide the motor bracket straight off. Do not attempt to remove the motor bracket without first removing the "O" rings (#8).

8. Remove the seat portion of the seal. Refer to Figure 4-10.

a. Place the motor bracket face down on a flat surface.

b. Look into the opening in the center of the bracket, you will see a portion of the seat.

c. Insert the 1" dowel, and very gently, tap the seat until it drops out. Care must be taken with the seats. They are often a brittle material and are prone to breakage. **It is recommended that a new replacement seat be installed during reassembly.**

parts that show visible wear. If the pump was not producing sufficient pressure or capacity, the clearances between the casing and impeller probably exceed the maximum allowable clearance. At minimum the impellers should be replaced in this case. If the total side running clearance for an impeller exceeds .007", it is unlikely that pump performance will reach that of a new pump except at lower discharge pressures.

The "O" rings and other elastomeric components should be replaced if they have been deformed or cut.

If seal components must be reused,

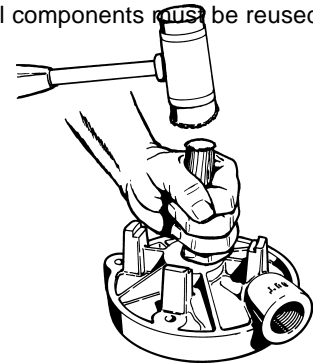

Figure 4-10

### 4D Inspection of Components

Thoroughly clean all parts. All components should be examined for wear and corrosion. Replace any

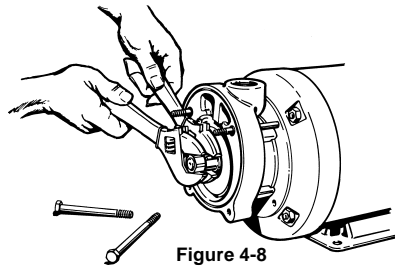

Figure 4-8

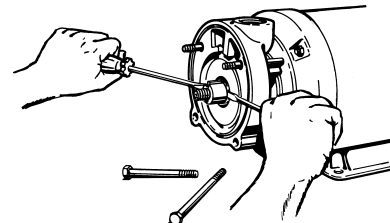

Figure 4-9

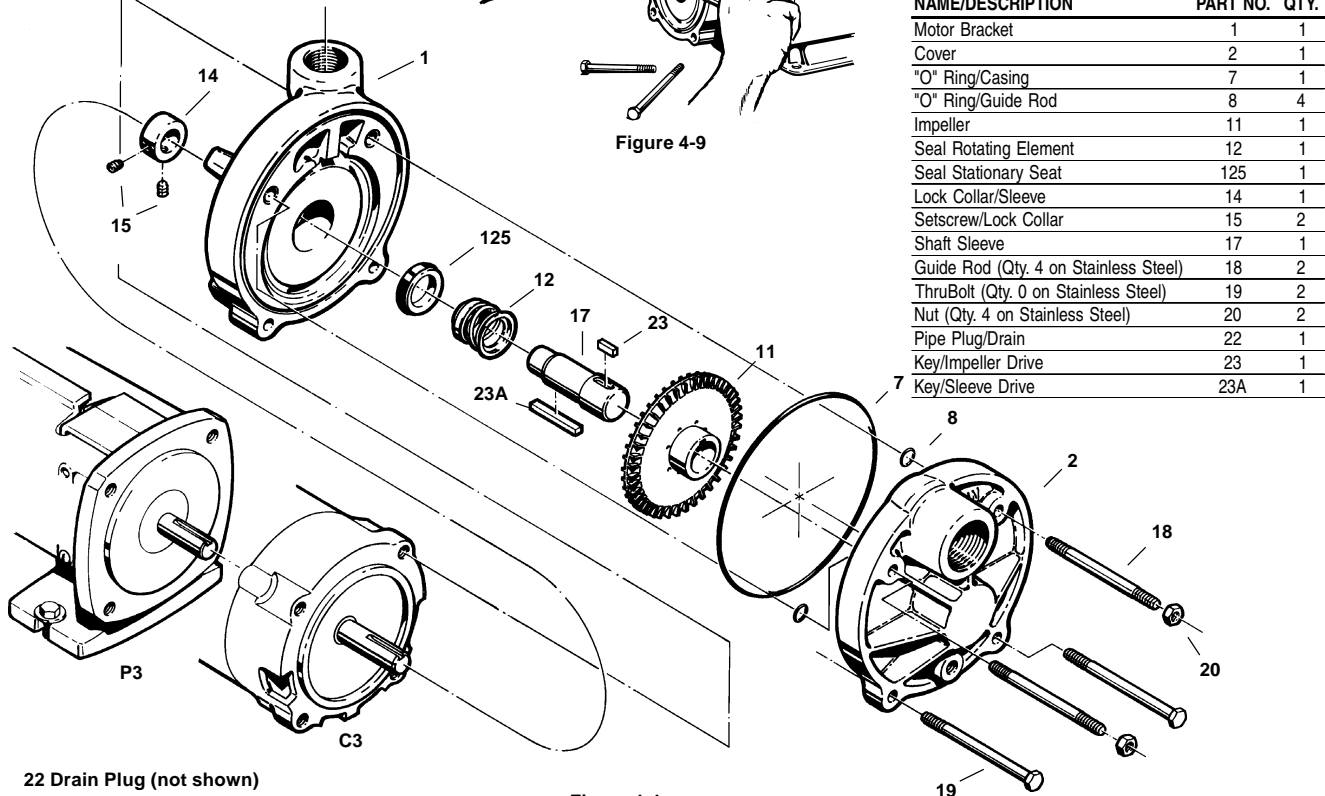

Figure 4-4

### C3 - P3 CLOSE COUPLED PUMP

NAME/DESCRIPTION	PART NO.	QTY.
Motor Bracket	1	1
Cover	2	1
"O" Ring/Casing	7	1
"O" Ring/Guide Rod	8	4
Impeller	11	1
Seal Rotating Element	12	1
Seal Stationary Seat	125	1
Lock Collar/Sleeve	14	1
Setscrew/Lock Collar	15	2
Shaft Sleeve	17	1
Guide Rod (Qty. 4 on Stainless Steel)	18	2
ThruBolt (Qty. 0 on Stainless Steel)	19	2
Nut (Qty. 4 on Stainless Steel)	20	2
Pipe Plug/Drain	22	1
Key/Impeller Drive	23	1
Key/Sleeve Drive	23A	1

22 Drain Plug (not shown)

carefully inspect for microscopic cracks and nicks. Scratches that might be ignored elsewhere can produce leakage if they are on seal carbons and seat wearing surfaces.

Cleanliness is imperative when working with mechanical seals. Almost unnoticeable particles between seal faces can be, and often are, the cause of early seal failures.

Check the impellers, they are designed to float. They should move easily on the shaft. As long as they can be moved on the shaft by hand, they are loose enough. If the impeller can be rocked or wobbled, it is too loose and must be replaced.

Check the sleeve or shaft for galling, pitting, and corrosion. If the shaft or sleeve is corroded where the seal comes in contact with them, the shaft or sleeve must be replaced. Surface corrosion must be removed so that seals can slide freely during assembly. The shaft diameter should be no smaller than .002" below the nominal fractional seal sizes. Remove any nicks or burrs which may have occurred during disassembly. Reclean parts as necessary.

**4E Reassembly (C3 and P3)**

All parts should be visually inspected and cleaned or replaced as outlined in 4D above.

1. The seal seat (#125) must be installed in the motor bracket before the bracket is installed on the motor. To install the seat:

a. Place the motor bracket face up on a flat surface.

b. Carefully press the seat, smooth side up, into the seat cavity of the motor bracket. To make the installation of the seat easier, apply a thin coating of compatible lubricant to the elastomer portion of the seat prior to installation. Care must be taken not to damage the seat face. Thumb pressure is usually sufficient to install the seat.

2. Install the motor bracket.

a. Make sure the locking collar is positioned on the motor shaft.

b. While holding the motor bracket with the outlet port facing up, slide the bracket over the two (2) studs on the motor face.

c. Slide the bracket back until the feet are resting against the motor face. Light tapping may be necessary to seat the motor bracket in the proper position.

d. Install the four (4) "O" rings (#8) on the two studs. This will help hold the bracket in place during the remainder of the assembly operation.

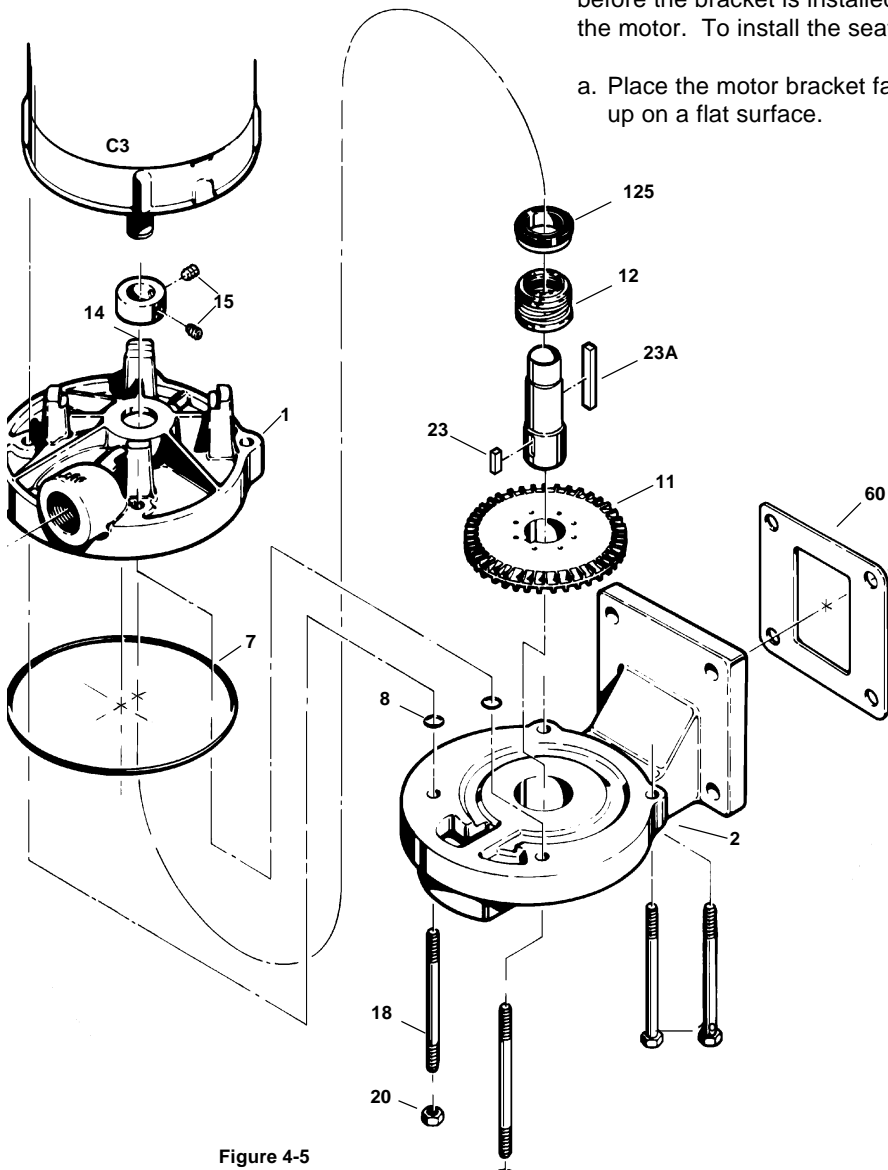

Figure 4-5

**C3 VERTICAL FLANGE MOUNT PUMP**

NAME/DESCRIPTION	PART NO.	QTY.
Motor Bracket	1	1
Cover/Vertical	2	1
"O" Ring/Casing	7	1
"O" Ring/Guide Rod	8	4
Impeller	11	1
Seal Rotating Element	12	1
Seal Stationary Seat	125	1
Lock Collar/Sleeve	14	1
Setscrew/Lock Collar	15	2
Shaft Sleeve	17	1
Guide Rod	18	2
ThruBolt	19	2
Nut	20	2
Pipe Plug/Drain	22	1
Key/Impeller Drive	23	1
Key/Sleeve Drive	23A	1
Gasket	60	1

T51 SERIES

# 4. Service

3. Install the shaft sleeve and rotating element as a unit.
  - a. Place the sleeve in an upright position with the smaller end facing up.
  - b. Lubricate the shaft sleeve and rotating element.
  - c. Be sure to install a key (#23A) in the motor shaft before installing the sleeve and seal assembly.
  - d. Holding the element assembly between the thumb and index finger of both hands, refer to Figure 4-13, slide the assembly over the sleeve until the spring holder rests against the shoulder of the sleeve.
  - e. The element must slide freely up and down on the sleeve. It is necessary to maintain some downward pressure on the element because the spring tension could dislodge the seal portion of the element.
  - f. Holding the assembled sleeve between the thumb and index

- finger, slide the assembly onto the motor shaft.
- g. Push the sleeve on until it comes in contact with the locking collar.
- h. Position the collar over the sleeve end and push the sleeve on until the holder is 1/32" to 1/16" below the impeller wearing surface of the motor bracket.
- i. While maintaining inward pressure on the sleeve with one hand, line up the collar setscrews with the key in the shaft sleeve, one setscrew on each side of the key.
- j. Tighten the setscrews snugly.
- k. Pressure can now be released, the sleeve should remain in position. The spring holder must be below the impeller wearing surface of

the motor bracket for proper impeller operation.

4. Install the impeller.
  - a. Place a key (#23) in the shaft sleeve.
  - b. The impeller is a slip fit and should slide on firmly but easily until it stops against the impeller wearing surface. Force should not be required to install the impeller in the correct position.

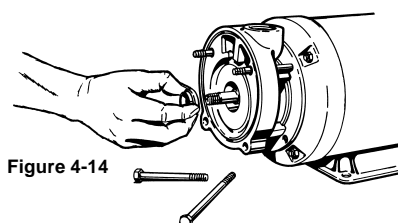

Figure 4-14

## C15 - P15 CLOSE COUPLED PUMP

NAME/DESCRIPTION	PART NO.	QTY.
Motor Bracket	1	1
Cover	2	1
"O" Ring/Casing	7	1
"O" Ring/Guide Rod	8	4
Impeller	11	1
Seal Rotating Element	12	1
Seal Stationary Seat	125	1
Drive Sleeve/Impeller Drive	14	1
Impeller Nut	15	1
Guide Rod (Qty. 4 on Stainless Steel)	18	2
ThruBolt (Qty. 0 on Stainless Steel)	19	2
Nut (Qty. 4 on Stainless Steel)	20	2
Pipe Plug/Drain	22	1
Key/Impeller Drive	23	1
Key/Sleeve Drive	23A	1

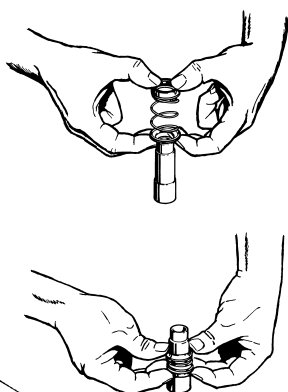

Figure 4-13

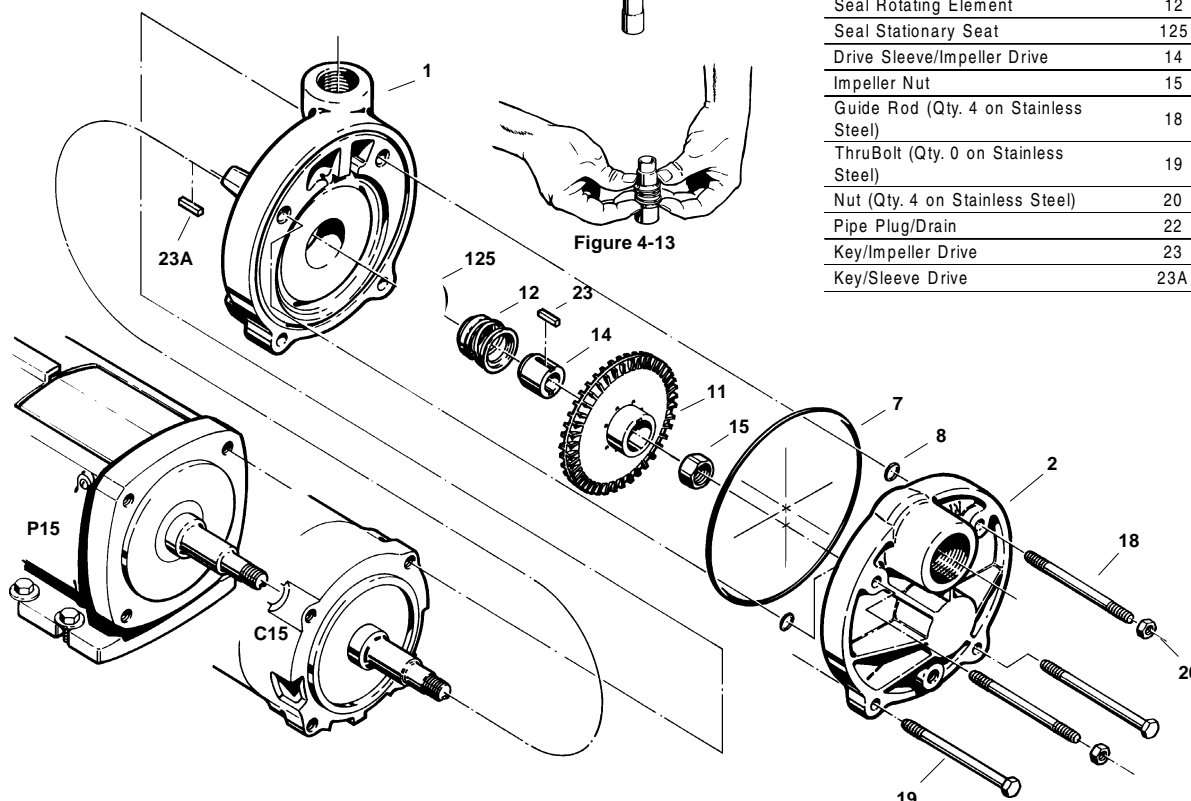

Figure 4-11

- c. The impeller hub should be facing out away from the motor bracket. Refer to Figure 4-4 and 4-5.
  - d. If the impeller does not fit, repeat steps a. and b. to determine the problem.
5. Place "O" ring (#7) into the "O" ring groove in the motor bracket. It is helpful to stand the motor and pump assembly on end for this procedure.
  6. Place the cover over the studs and install the two (2) 3/8" nuts and two (2) 3/8"x4" bolts. Tighten the nuts and bolts systematically, alternating diagonally across the cover.
  7. After the nuts and bolts are "snugged up", make sure the impeller is not binding by inserting a 5/32" hex wrench into the locking collar and moving it left to right. The collar should rotate with little or no resistance. If the collar will not turn, loosen the two (2) 3/8" nuts and bolts equally until the impeller moves freely.

Proceed to Section 4G Testing and Final Adjustments.

**4F Reassembly (C15 and P15)**

All parts should be visually inspected and cleaned or replaced as outlined in 4D above.

1. The stationary seat (#125) must be installed in the motor bracket before the bracket is installed on the motor. To install the seat:
  - a. Place the motor bracket face up on a flat surface.
  - b. To make the installation of the seat easier, apply a thin coating of compatible lubricant to the elastomer portion of the seat prior to installation.
  - c. Carefully press the seat, smooth side up, into the seat cavity of the motor bracket. Care must be taken not to damage the seat face. Thumb pressure is usually sufficient to install the seat.
2. Install the motor bracket.
  - a. While holding the motor bracket with the outlet port facing up, slide the bracket

- over the two (2) studs (#18) on the motor face.
  - b. Slide the bracket back until the feet are resting against the motor face. Light tapping may be necessary to seat the motor bracket in the proper position.
  - c. Install the four (4) "O" rings (#8) on the two studs. This will help hold the bracket in place during the remainder of the assembly operation.
3. Install the sleeve hub and rotating element as a unit.
    - a. Place the sleeve in an upright position with the smaller end facing up.
    - b. Lubricate the motor shaft with a small amount of glycol based lubricant.
    - c. It is generally easier to remove the entire head or sealing assembly from the spring and install it on the motor shaft. Refer to Figure 4-14. This assembly lifts out of the rotating element spring.
    - d. After removal, apply a thin layer of lubricant to the elastomer portion of the seal.

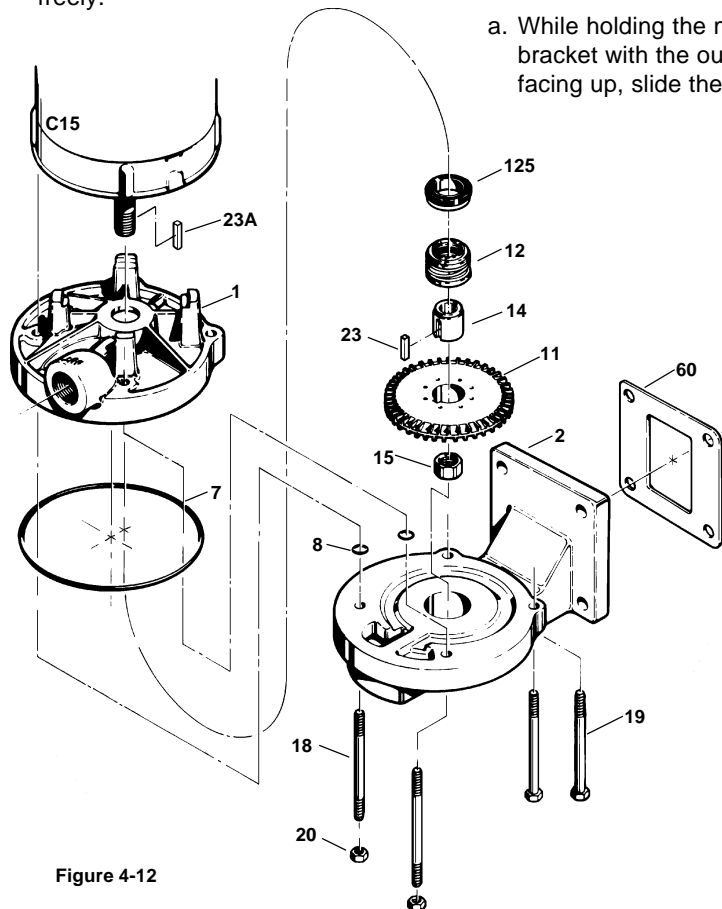

Figure 4-12

**C15 VERTICAL FLANGE MOUNT PUMP**

NAME/DESCRIPTION	PART NO.	QTY.
Motor Bracket	1	1
Cover/Vertical	2	1
"O" Ring/Casing	7	1
"O" Ring/Guide Rod	8	4
Impeller	11	1
Seal Rotating Element	12	1
Seal Stationary Seat	125	1
Drive Sleeve/Impeller Driver	14	1
Impeller Nut	15	1
Guide Rod (Qty. 4 on Stainless Steel)	18	2
ThruBolt (Qty. 0 on Stainless Steel)	19	2
Nut (Qty. 4 on Stainless Steel)	20	2
Key/Impeller Drive	23	1
Key/Sleeve Drive	23A	1
Gasket	60	1

## T51 SERIES

**4. Service**

- e. Holding the head assembly between the thumb and index finger, with the sealing face pointing toward the stationary seat, slide the assembly over the motor shaft until it rests against the seat. Refer to Figure 4-14. A slight twisting motion will allow the assembly to slide more easily.
- f. Check to see that the head assembly is against the seat face.
- g. Position the rotating element spring with the spring holder resting against the shoulder of the sleeve hub.
- h. Align the keyway slot in the hub assembly, and the key in the motor shaft. Refer to Figure 4-14,
- i. Slide the hub and spring assembly over the shaft until the hub is properly seated and the spring is positioned correctly on the rotating element head previously installed. Refer to Figure 4-11 and 4-12.
- j. While maintaining inward pressure on the hub, install the impeller nut. Refer to Figure 4-16.
- k. Tighten the nut as far as possible by hand.
- l. Pressure can now be released.
- m. To tighten the nut, place a crescent wrench over the hub sleeve and engage the drive key.

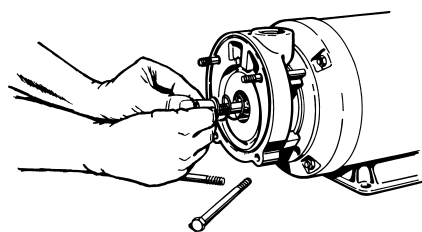

Figure 4-15

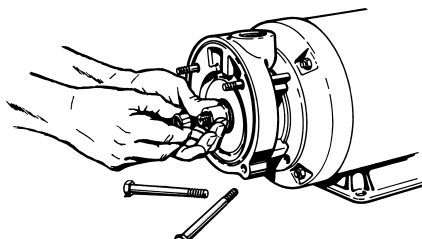

Figure 4-16

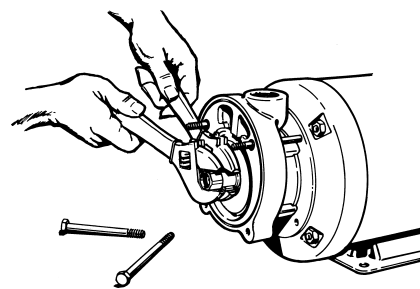

Figure 4-17

- n. Place a second crescent wrench over the nut and tighten in a clockwise direction until it is secured. Refer to Figure 4-17.
4. Install the impeller.
    - a. The impeller is a slip fit and should slide on firmly but easily until it stops against the impeller wearing surface. Force should not be required to install the impeller in the correct position.
    - b. The impeller hub should be facing out away from the motor bracket.
    - c. If the impeller does not fit, repeat steps a. and b. to determine the problem.
  5. Place "O" ring (#7) into the "O" ring groove in the motor bracket. It is helpful to stand the motor and pump assembly on end for this procedure.
  6. Place the cover over the studs and install the two (2) 3/8" nuts and two (2) 3/8"x4" bolts. Tighten the nuts and bolts, systematically alternating diagonally across the cover. Do not over-tighten the nuts and bolts; final adjustment will be made after the unit is in operation.

**4G Testing and Final Adjustment**

The pump is now ready for installation. Final adjustments will be made with the pump in operation.

1. Reconnect the electrical connections referring to the colored or numbered tape used to mark the wires during disassembly.
2. Connect all piping and fill the pump with fluid.
3. Make sure all valves are open, and fluid will flow through the system.
4. Start the pump and make the final adjustments to the 3/8" nuts and bolts holding the cover on. These nuts and bolts must be torqued to 20 ft. lbs. to obtain proper performance.
5. Check for leaks on pump and piping. Special attention should be given to the seal area at the rear opening in the motor bracket.
6. Under pressure, the impeller will find its "hydraulic" balance.
7. Using an amprobe or similar device, check for motor overload.
8. While the impeller is seating, it is common to experience some variance in readings. After a run-in period the readings should level off.

This completes the adjustment and testing phase. The pump is ready for service.

## T51 SERIES

# 4. Service

## BEARING PEDESTALS

- A. Preliminary
- B. Disassembly
- C. Inspection of Components
- D. Reassembly
- E. Testing and Final Adjustments

### 4A Preliminary (P3 and P15)

1. Disconnect the inlet and outlet-piping before unbolting the pump. If the pipes are corroded, use penetrating oil on the threads to aid in removal.
2. Unbolt the pump from the base and remove. Disassembly instructions for the pump are found in section 4, T51 PUMP ENDS. All work on the unit should be performed on an elevated workbench whenever possible.

The disassembly and reassembly procedures are broken into two sections covering the following units:

- 4B — Disassembly of the P3 and P15 Bearing Pedestals
- 4D — Reassembly of the P3 and P15 Bearing Pedestals

Exploded views of each unit, Figures 4-19 and 4-20 are provided for referencing the numbers in the following procedures, i.e. flinger (#21).

### 4B Disassembly (P3 and P15)

The following tools and equipment are needed for disassembly of the P3 and P15 units:

1. Soft plastic or wooden mallet.
2. Arbor press or vise.
3. 3/4" X 6" piece of water pipe for P3, 1-1/4" X 6" for P15.
4. Internal snap ring plier.
5. Penetrating oil.

When installing or removing bearings from the shaft, the use of an arbor press is strongly recommended.

To disassemble the pedestal:

Refer to Figures 4-19 and 4-20 for reference to the numbered parts in the procedures below.

1. Remove the flinger (#21) located in the pump end of the bearing pedestal (#3).
2. Using a snap ring plier, remove snap ring (#4).
3. Open the jaws of the vice approximately 2-1/4" for model P3 and 3" for model P15.
4. Place the pedestal, pump side down, on the jaws. Refer to Figure 4-18.
5. Using a plastic or wooden mallet, gently tap on the end of the shaft until it slides out of the frame. Both bearings should come out with the shaft. Do not use a metal hammer; severe damage to the shaft will occur.
6. Using the arbor press remove the two (2) bearings from the shaft. Refer to Figure 4-21. If the inner race is well supported during this operation, no damage

will be done to the bearings.

If an arbor press is not available, a bench vise may be substituted using the following instructions.

1. Remove the pedestal and close the jaws to approximately 1-1/8" for model P3 and 1-3/8" for model P15.
2. Place the shaft with either bearing resting on top of the jaws and gently tap on the end of the shaft until the bearing is removed. Refer to Figure 4-22.
3. Repeat step 2 to remove the other bearing. Good support used on the inner races will prevent bearing damage.

### 4C Inspection of Components

Thoroughly clean all parts. All components should be examined for wear and corrosion. Replace any parts showing visible wear.

Check to be certain that a press fit still exists between the shaft and the bearings. New bearings, or at least cleaned and regreased bearings, are recommended. Check the shaft for galling, pitting, and corrosion. Surface corrosion on the pump portion of the shaft must be removed so the seals will slide freely during assembly. The shaft diameter should be no smaller than .002" below the nominal fractional seal sizes. Remove any nicks or burrs which may have occurred during disassembly. Reclean parts as necessary.

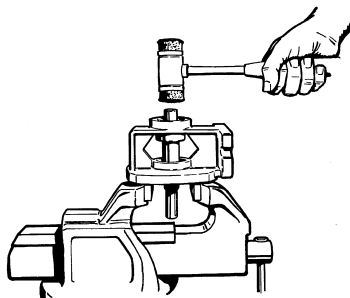

Figure 4-18

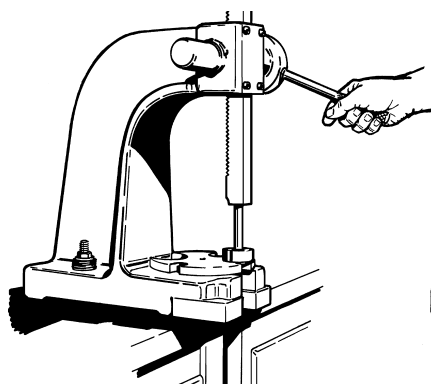

Figure 4-21

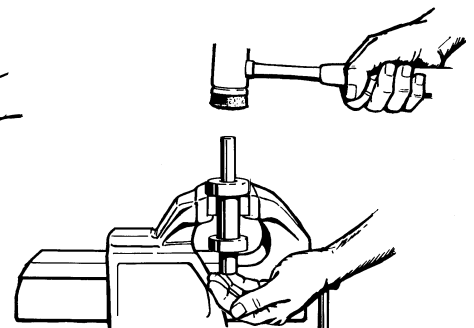

Figure 4-22

## T51 SERIES

## 4. Service

### 4D Reassembly

All parts should be visually inspected and cleaned or replaced as outlined in 4C above. It is recommended that the bearings be replaced any time the bearing pedestal is disassembled for service.

- Using an arbor press, install the bearings on the shaft prior to installing the shaft into the pedestal. A steel "donut" with the proper inside diameter and outside diameter, refer to Chart 1, should be used between the arbor face plate and the lower bearing to insure proper installation and to prevent bearing damage. The bearings must seat against the shoulder for proper alignment. Refer to Figure 4-23. \*Also refer to Alternate bearing installation procedures.

**CHART 1**

	P3	P15
Inside Diameter	1"	1 1/4"
Outside Diameter	2"	2 3/4"

- Place the pedestal, pump mounting surface up, in a vise or suitable fixture and insert the bearing assembly. It should be possible to install the shaft assembly with firm thumb pressure. Refer to Figure 4-24. If more force is required, the butt end of a hammer handle or plastic mallet may be helpful. The shaft assembly should never be forced or driven in.

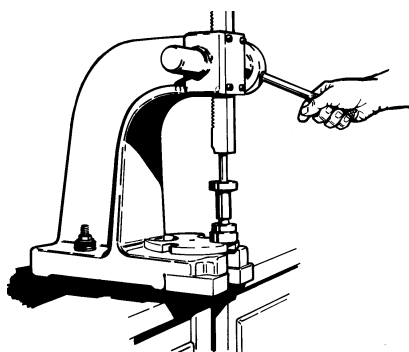

Figure 4-23

- Install the snap ring (#4) in the pump end of the pedestal. Be sure the snap ring is seated properly in the groove. The beveled edge of the ring should face away from the bearing.
- Install the flinger over the snap ring. The bearing pedestal is now ready for pump and motor installation.

### \*Alternate bearing installation procedures.

If an arbor press is not available, the bearings may be installed on the shaft using the following procedure:

This procedure is not recommended and should only be used in an emergency situation.

- Stand a piece of 3/4" pipe for P3 or a 1-1/4" piece of pipe for P15, with the threads cut off, on a workbench or similar flat surface, with the bearing placed on the correct shaft end.
- Insert the shaft into the pipe so the bearing is between the pipe and the shoulder of the shaft. Refer to Figure 4-25.
- Using extreme caution, gently tap on the end of the shaft until the bearing rests against the shoulder. Never attempt to install the bearings by striking the outer race.

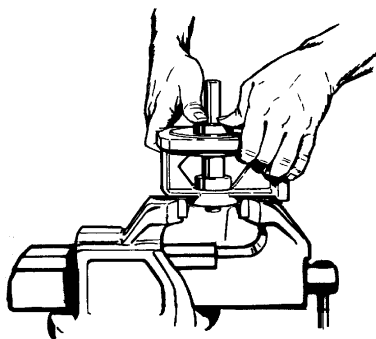

Figure 4-24

- Repeat step 3 for the other bearing.

### 4E Testing and Final Adjustments

- Check to be sure that the rotating assembly turns freely. Turn the shaft by hand. If it is tight or rough spots are encountered, it is likely that at least one of the bearings was damaged during disassembly/assembly operations and will have to be replaced.
- Look to make sure that the lip seals on the bearings are positioned properly in their grooves. Correct if necessary. As the bearings are turned, the grooves should appear wet with oil but have no visible grease present.
- Recheck the snap ring on the large bearing end. It should be firmly in place, and no axial motion should result from gentle tapping on either end of the shaft. (Use a soft mallet so shaft surfaces are not damaged.)
- No adjustments are possible or required. Proceed with the appropriate pump end assembly operations. Refer to Section 4 SERVICE - PUMP ENDS (Final testing is done after the pump end is in place.)

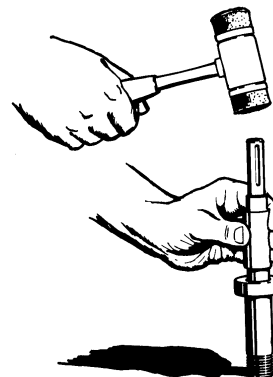

Figure 4-25



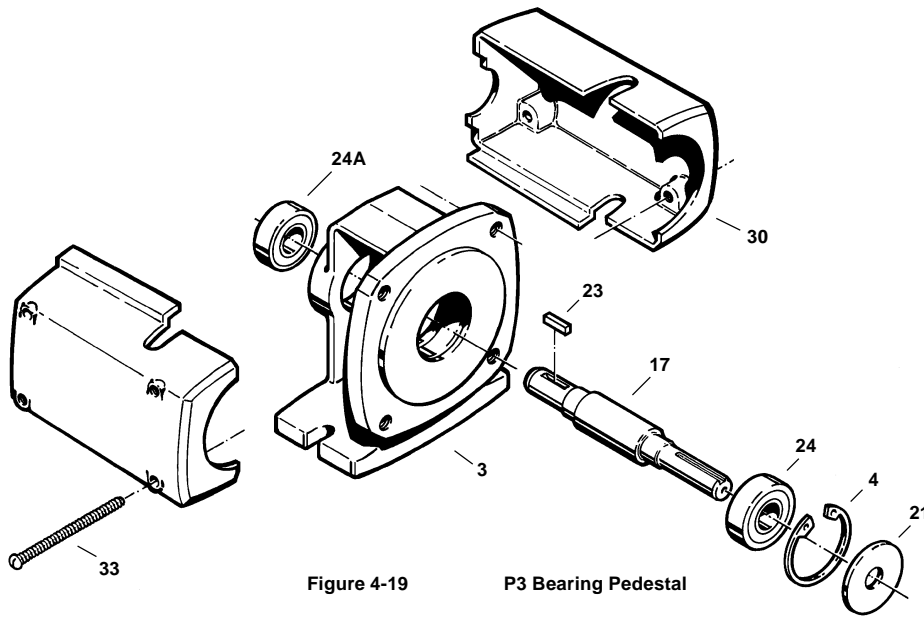

Figure 4-19 P3 Bearing Pedestal

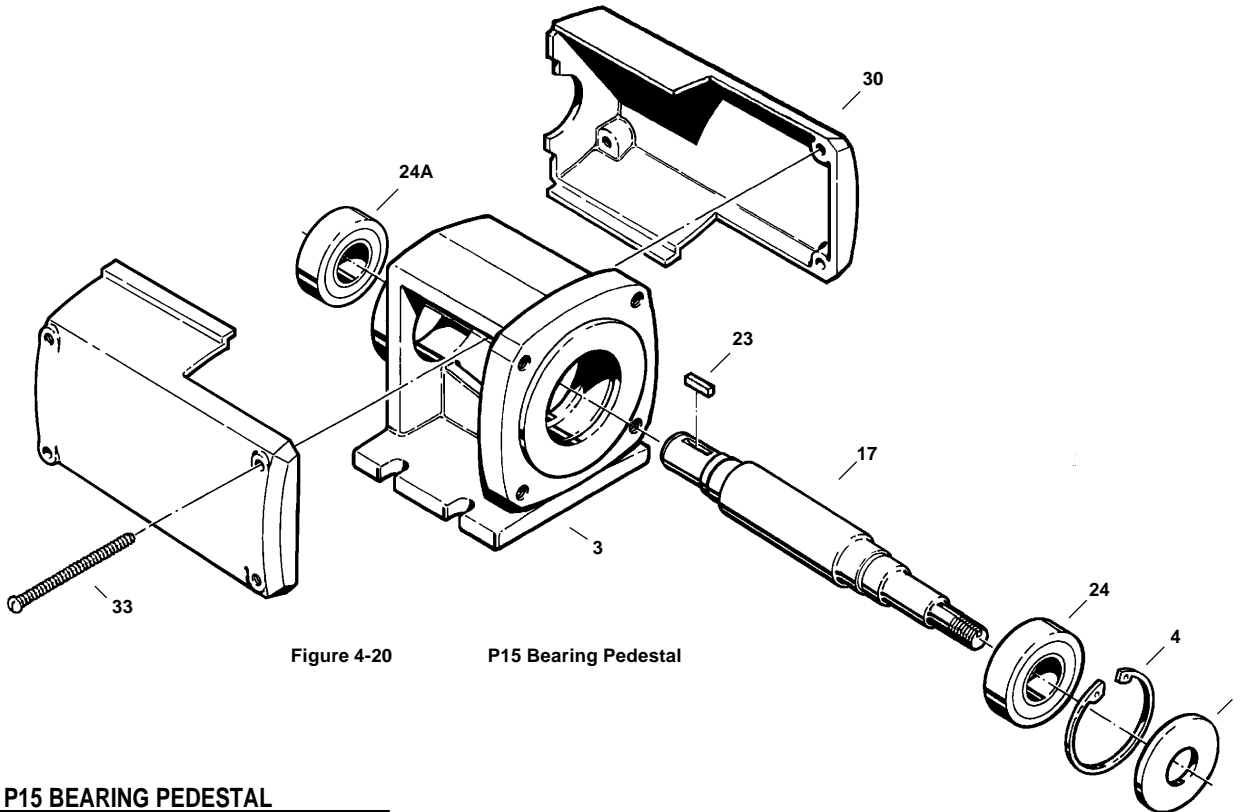

Figure 4-20 P15 Bearing Pedestal

**P3 & P15 BEARING PEDESTAL**

NAME/DESCRIPTION	PART NO.	QTY.
Bearing Pedestal	3	1
Snap Ring/Bearing Retainer	4	1
Shaft	17	1
Flinger	21	1
Key Coupling	23	1
Ball Bearing/Inboard	24	1
Ball Bearing/Outboard	24A	1
Coupling Guard/Halves	30	2
Capscrew	33	4

## T51 SERIES

# 5. Troubleshooting

FLEXIBLE COUPLED PUMPS

CLOSE COUPLED PUMPS

VERTICAL FLANGE MOUNTED PUMPS

- A. Failure to Pump
- B. Reduced Capacity
- C. Reduced Pressure
- D. Pump Loses Prime After Starting
- E. Excessive Power Consumption
- F. Pump Vibrates or is Noisy
- G. Mechanical Problems
- H. Seal Leakage

## 5A Failure to Pump

1. Pump not up to speed — Use tachometer to determine actual RPM. Check voltage and wiring connections.
2. Pump not primed — Confirm that pump and all inlet piping is filled with fluid.
3. Discharge head too high — Install a pressure gauge at the pump discharge to determine the actual operating pressure. Compare readings with pump performance curve. A larger pump may be necessary.
4. Excessive suction lift — Relocate pump, supply tank, or both to minimize suction lift.
5. Wrong direction of rotation — Compare pump rotation with arrow on pump. Standard pumps rotate in a clockwise direction when looking at the shaft extension end or from the motor end on close coupled pumps. Reverse two leads on a three phase motor to change rotation. Check motor nameplate for single phase operation.
6. Clogged suction line, strainer or valve — Inspect and clean out if necessary.
7. Air pocket in suction line — Look for high spots in inlet piping system. Evacuate the system with a vacuum pump if necessary.

## 5B Reduced Capacity

1. Pump not up to speed — Use a tachometer to determine actual RPM. Check voltage and wiring connections.
2. Excessive suction lift — Relocate pump, supply tank or both to minimize suction lift.
3. Insufficient NPSH — Relocate pump, supply tank or both to improve NPSH available if possible. Increase suction pressure. Reduce fluid temperature. Select a pump with lower NPSH requirements.
4. Mechanical damage — Rotate the pump by hand to determine if there are tight spots. Broken or bent impeller vanes can sometimes be detected in this manner. If there is a suspicion of damage, remove the pump from service and disassemble for inspection.
5. Air leak in the suction line — Fill the system with fluid and hydrostatically test. Tighten connections or replace leaky components.
6. Air pockets in the suction piping — Operating the system at maximum flow conditions will usually clear the lines. Evacuate the system with a vacuum pump if necessary.
7. Suction lines, strainer, or foot valve too small or clogged — Inspect and clean out as necessary. Fittings and lines should be at least equal to the pump suction size.
8. Discharge head too high — Install a pressure gauge at the pump discharge to determine the actual operating pressure. Compare readings with pump performance curve. A larger pump may be necessary.

9. Excessive wear — If a pump had previously performed satisfactorily and now gives evidence of reduced performance, it should be disassembled and examined for wear after the simpler possible problems have been investigated.

## 5C Reduced Pressure:

1. Pump not up to speed — Use a tachometer to determine actual RPM. Check voltage and wiring connections.
2. Air or vapor in liquid — Install a separator in the suction line. Check the seal on the inlet end of the pump to determine if air is being drawn in. Hydrostatically test the system to insure that there are no leaks.
3. Mechanical wear or damage — Rotate the pump by hand to determine if there are tight spots. Broken or bent impeller vanes can sometimes be detected in this manner. If there is a suspicion of damage or wear, remove the pump from service and disassemble for inspection. Look for wear on the impeller, suction cover, and motor bracket.
4. System head less than expected — Replace pump with higher capacity unit or add a valve or orifice to increase line resistance.

## 5D Pump Loses Prime After Starting

1. Leak in suction line — Fill the system with fluid and hydrostatically test. Tighten connections or replace leaky components.
2. Air entering pump through inlet seal or "O" rings — Hydrostatically test the pump and look for leaks. Replace faulty seals or "O" rings.

3. Insufficient NPSH or too much suction lift — Relocate pump, supply tank, or both to improve inlet conditions. Increase suction pressure. Reduce fluid temperature. Select a pump with lower NPSH requirements.

### 5E Excessive Power Consumption

1. Speed too high — Check RPM with tachometer.
2. Discharge head too high — Install a pressure gauge at the discharge to determine the actual operating pressure. Compare readings with pump performance curve. A different pump, motor, or both may be necessary.
3. Specific gravity or viscosity too high — Check fluid involved. A different motor may be necessary.
4. Mechanical damage — Turn pump over by hand. After a few days run in period, all models should turn over by hand with no tight spots. An exception to this is when the pump has been idle for some time. In this case, run the pump for a few hours before checking for tight spots. If there is a suspicion of damage, remove the pump from service and disassemble for inspection.
5. Pump not fully "broken in" — It is normal for new pumps to consume higher than normal current during the break-in period. If high power consumption persists beyond a few weeks, it is unlikely that further operation will reduce consumption.
6. Pump not properly adjusted — Loosen all nuts on pump exactly one turn. Follow the instructions in 4G Testing and Final Adjustments for repositioning fasteners.

### 5F Pump Vibrates Or Is Noisy

1. Pump and motor are mis-aligned — Follow the installation instructions for proper alignment.

2. Insecure mounting — Follow instructions in Section 2, 2B Foundation.
3. Piping load on pump — Install piping supports and check to see that there is no strain on the pump.
4. Mechanical damage — If mechanical damage is suspected, check first to determine if the pump turns freely. Disassemble for inspection if tight spots are found.
5. Pump has a high pitched whine — This is typical of a regenerative turbine pump. The intensity should increase as pressure increases. Over a period of a few weeks the noise level will diminish and will become noticeably quieter as the pump approaches a "run in" condition.

### 5G Mechanical Problems

1. Short bearing life — Bearings damaged due to leaky seals. Coupling misalignment. Piping load on pump. RPM or pump pressure too high.
2. Pump locked up — Pump dried out and close clearance areas rusted. Follow installation instructions for loosening the pump. Foreign material in pump. Flush out. Disassemble if flushing is not successful.
3. Pump leaks — Seal or "O" rings are usually the problem. Disassembly and replacement is the solution if tightening the through bolts has no effect.

### 5H Seal Leakage

1. Worn seat or rotating element — Seals will last many years operating on cold clear water or other fluids with reasonable lubricity. Particles, even microscopic, increase normal wear rates. Temperatures near the fluid's boiling point can reduce lubricity, which, in turn, increases wear. Some chemicals will

erode the seal faces or plate out on the faces producing an abrasive effect. Immediate seal replacement is recommended when leaks become evident, since bearings are quickly ruined as a result of moisture. Severe mechanical damage results when the bearings fail.

2. Improperly installed seat or rotating element — If a seal has recently been replaced, look for a missing "O" ring/cup around the seat, or a seat that was installed cocked or backwards. The smooth surface should face the rotating element. The rotating element may be in backward or improperly positioned. Refer to the appropriate seal diagrams and instructions to confirm the correct seal orientation. Rotating elements sometimes stick in the wrong position if left partially assembled for some time. Make sure a rotating element can be moved axially on the shaft before closing up the pump, and then make the final adjustments as soon as possible.
3. Seat broken during assembly — Ceramic seats are particularly vulnerable to damage. Carefully follow reassembly instructions for seals. Seals on flex-coupled units can be damaged by excessive hammering when installing the shaft coupling onto the shaft extension.
4. Pitted shaft under the seal — Reusing a shaft or sleeve when repairing a pump is the probable cause of this problem. The seal rotating element can produce a pitted surface underneath its elastomer portion during normal use. This is normally not a problem for the first seal assembly since the elastomer is conforming as this action occurs. A new seal can leak before it conforms if the pits are large enough. If any pits are visible to the unaided eye, shaft or sleeve replacement is advised.

## T51 SERIES

# 6. Parts and Repair Services

- A. Parts
- B. Repair Service
- C. Warranty Service
- D. Motors, Mechanical Seals, and Accessories

### 6A Parts

Repair parts may be obtained through your local Authorized MTH Pumps Representative or Distributor who can be found in the yellow pages or by contacting MTH Pumps at 401 W. Main St. • Plano, IL 60545 Phone: 630-552-4115 Fax: 630-552-3688.

### 6B Repair Services

Repair service for an MTH pump should be obtained from the company through which it was purchased.

In the event this is not possible, the name and phone number of a nearby MTH representative or distributor may be obtained by contacting MTH Pumps. In the event that it is necessary to return the pump to the factory for repairs, remove all accessories attached to the pump. We cannot accept responsibility for their safe removal, storage, and return.

### 6C Warranty Service

All requests for warranty claims should be made through the company from which the pump was purchased or supplied. Complete details on what is wrong with the pump must be provided along with information on the system in which it is installed. Refer to the MTH Pumps Limited Warranty statement.

Return authorization must be obtained prior to returning any equipment.

### 6D Motors, Mechanical Seals, and Accessories

Repair or replacement service on motors, mechanical seals, relief valves, or other accessories should be obtained from the manufacturer of these components. MTH does not carry replacement parts and is not authorized to render repair service on these components. Replacement mechanical seals are stocked at MTH and are always available insofar as possible for immediate shipment. Warranty service, as well as expert application information can be obtained from your local seal manufacturer's sales office.

## T51 SERIES

# 7. Limited Warranty

MTH Tool Company, Inc. / MTH Pumps, hereinafter referred to as "MTH", warrants for a period of twelve (12) months from the date of shipment ("The Warranty Period"), that the pumps manufactured by it will be free from defects in material and workmanship. MTH will correct defects in material or workmanship which may develop in its products under proper or normal use during the Warranty Period and under the conditions of this Warranty. This Warranty does not extend to anyone except the original consumer-purchaser. Damage to the product due to improper handling, improper storage, improper maintenance, or improper application is not covered by this Warranty. Warranty claims for motors, mechanical seals, and accessories should be directed to those who manufactured the component. MTH will repair or replace, at its option and expense, its products proved to be

defective after examination by the Company. The defective Product must be returned, transportation prepaid, to the factory at Plano, Illinois. Disassembly of the equipment impairs determination of reasons for failure and shall be cause for voiding this Warranty. The Product, repaired or replaced, will be shipped f.o.b. MTH's factory. **This is MTH's sole warranty. MTH makes no other warranty of any kind, expressed or implied, and all implied warranties of merchantability and fitness for a particular purpose which exceed MTH's aforesaid obligations are hereby disclaimed by MTH and excluded from this warranty.** MTH neither assumes nor authorizes any person to assume for it, any other obligation in connection with the sale of the Product and any enlargement of this Warranty by a purchaser shall be for its own account and its exclusive responsibility. This Warranty shall not apply to any

Product or parts of Products which: (a) have been repaired or altered outside of MTH's factory, in any manner; or (b) have been subjected to misuse, negligence or accident; or (c) have been used in a manner contrary to MTH's printed instructions; or (d) have been damaged due to defective power supply or faulty installation. **MTH shall not be liable for incidental and consequential losses and damages under this express warranty, any applicable implied warranty, or claims for negligence, except to the extent that this limitation is found to be unenforceable under the applicable State law. Some States do not allow the exclusion or limitation of incidental or consequential damages, so the above limitation or exclusion may not apply to you. This warranty gives you specific legal rights, and you may also have other rights which vary from State to State.**



## MTH PUMPS

401 West Main Street • Plano, IL 60545-1436  
Phone: 630-552-4115 • Fax: 630-552-3688