

Features & Options

- 2" X 2" SELF PRIMING CENTRIFUGAL PUMP
- PEDESTAL FOR STANDARD MOTOR
- FLOWS TO 150 GPM
- PRESSURES TO 100 FEET HEAD
- ALL POLYPROPYLENE CONSTRUCTION
- SELF PRIMING TO 20 FT.
- SEALS & ELASTOMERS—EPDM
- OPTIONS: —ENGINE DRIVES
—HYDRAULIC DRIVES

DIMENSIONS

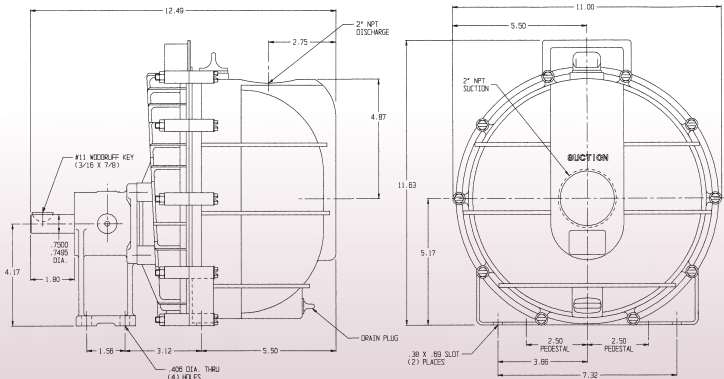

Pump Performance Curves

