



HYDRASUB 25 2 1/2"

- **SUBMERSIBLE**
- **HIGH FLOW**
- **HYDRAULIC DRIVEN**
- **COMPACT DESIGN**

HYDRASUB 25 is a compact, lightweight, hydraulically driven submersible pump with high flow capabilities. This self-priming pump is made with a high strength aluminum alloy that is anodized for corrosion resistance. This pump features a stainless steel impeller, ball bearing, and a gerotor type hydraulic motor.

FLOW RATES UP TO 430 GPM

STAINLESS STEEL IMPELLER

CORROSION
RESISTANT

ANODIZED ALUMINUM
ALLOY BODY

STAINLESS STEEL
COMPONENTS

SELF-PRIMING,
CAN RUN DRY
WITHOUT DAMAGE

QUIET OPERATION
WITH GEROTOR
MOTOR

COMPACT,
LIGHTWEIGHT
DESIGN

CARRYING
HANDLE

SPECIFICATIONS

Capacity..... Up to 430 gpm (1,628 lpm)
System..... Open and Closed Center

Hydraulic Ports..... 7/8-14 SAE O-RING
Oil Flow Range..... 8-14 gpm (30-53 lpm)
Max Oil Pressure..... 2000 psi (13,790 kPa)
Max Back Pressure..... 100 psi (690 kPa)

Pump Outlet Port..... 2-1/2" A-Type Cam and Groove
Max Solids..... Up to 1/2"

Pumps down to 3/4 " from bottom

Weight..... 13 lbs (4.85 kg)
Height..... 11.5 " Over Handle (29.2 cm)
Width..... 10" diameter (24.13 cm)

 **MP PUMPS, INC.**
TECUMSEH PRODUCTS COMPANY
34800 BENNETT DRIVE • FRASER, MI 48026-1686
(586) 293-8240 • FAX (586) 293-8469
(800) 563-8006
www.mppumps.com

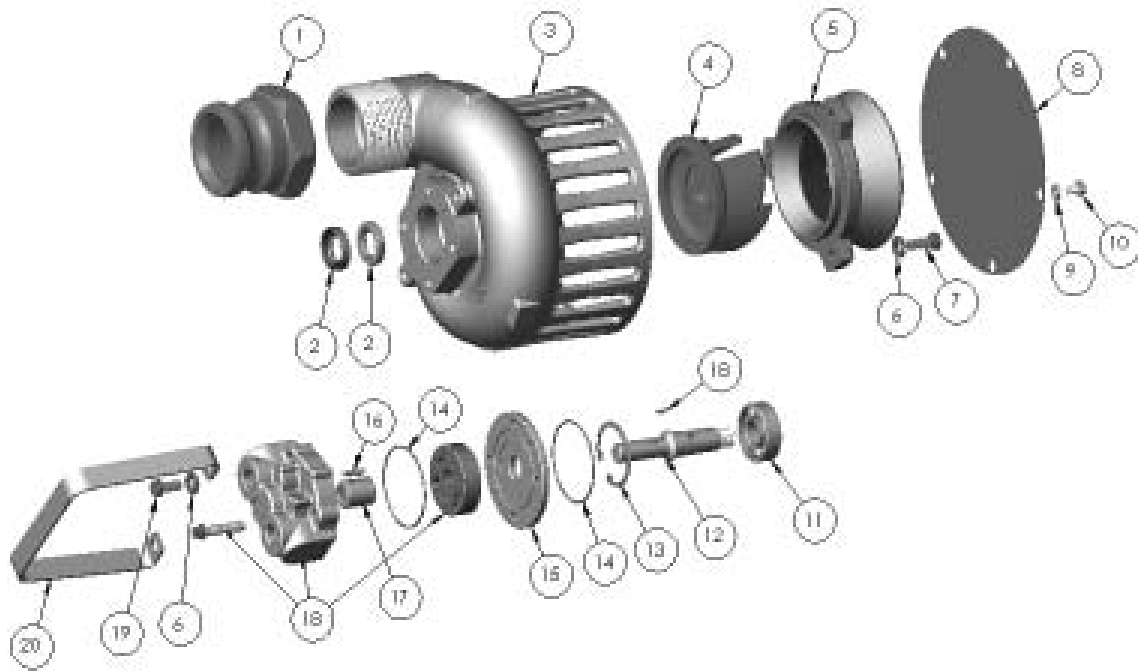

ITEM	PRT. NO.	QTY.	DESCRIPTION	ITEM	PRT. NO.	QTY.	DESCRIPTION	ITEM	PRT. NO.	QTY.	DESCRIPTION
1	34023	1	2 1/2" COUPLING	8	33716	1	COVER PLATE	15	33724	1	THRUST PLATE
2	33718	2	LIP SEAL	9	33864	5	1/4" LOCKWASHER	16	33740	2	DOMEL PIN
3	33783	1	HOUSING	10	30651	5	1/4-20 X 3/8" CAPSCREW	17	29046	1	NEEDLE BEARING
4	30651	1	IMPELLER SG	11	27556	1	BALL BEARING	18	33893	1	HYD. MOTOR
5	33715	1	SUCTION FLANGE	12	33720	1	SHAFT	19	30320	2	5/16-18 X 1/2" CAPSCREW
6	21238	5	5/16" LOCKWASHER	13	33742	1	RETAINING RING	20	33778	1	HANDLE
7	21242	3	5/16-18 X 7/8" CAPSCREW	14	34054	2	GUARD RING				

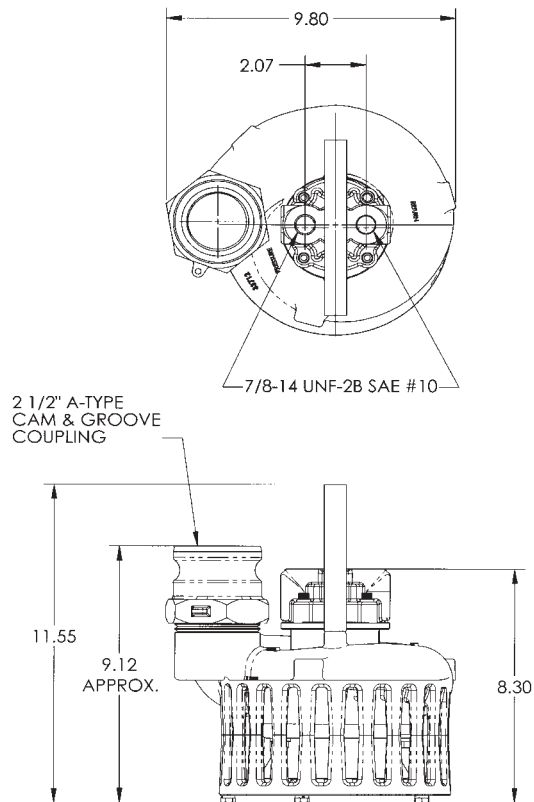
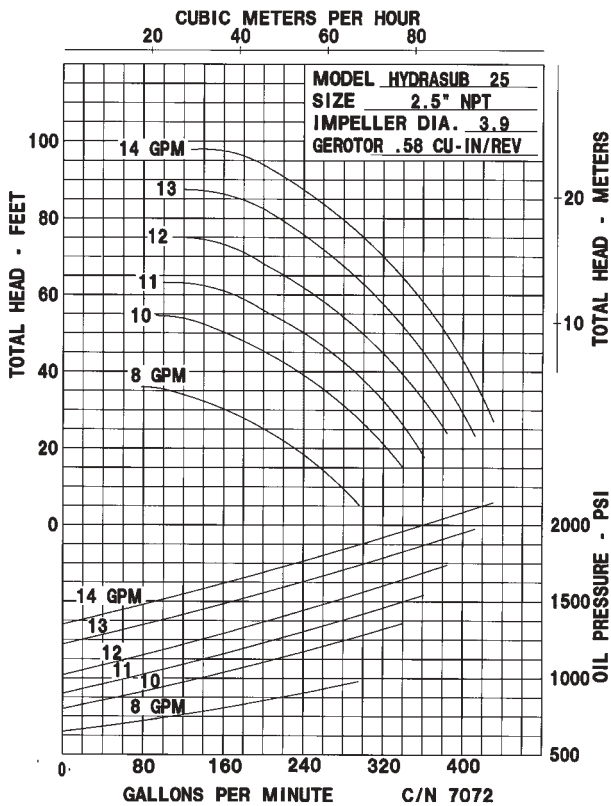

MP PUMPS, INC.
 TECUMSEH PRODUCTS COMPANY
 34800 BENNETT DRIVE • FRASER, MI 48026-1686
 (586) 293-8240 • FAX (586) 293-8469
 (800) 563-8006
www.mppumps.com