

Features & Options

- 4" X 4" SELF PRIMING CENTRIFUGAL PUMP
- ELECTRIC MOTOR DRIVE
- STAINLESS STEEL CUTWATER
- FLOWS TO 800 GPM
- PRESSURES TO 120 FEET HEAD
- CAST IRON CONSTRUCTION
- REPLACEABLE FLANGES
- IMPELLER—DUCTILE IRON, 3 VANE SEMI-OPEN, NON-CLOG DESIGN. MAXIMUM 1 1/4" DIAMETER SOLIDS
- BEARING PEDESTAL—WITH REGREASABLE BALL BEARINGS
- PUMP SHAFT—HIGH STRENGTH PRECISION GROUND ALLOY STEEL
- SEALS—JAEGER "LUBRI-SEAL" MECHANICAL SEAL WITH HARDENED STAINLESS STEEL SEAT AGAINST BRONZE FACE (GREASE LUBRICATED)
- OPTIONS: —CARBON/CERAMIC SEALS
—TUNGSTEN CARBIDE SEALS
—ENGINE DRIVES

DIMENSIONS

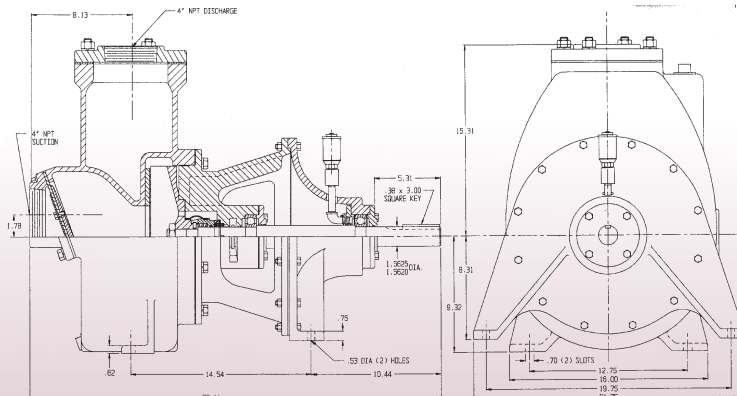

Pump Performance Curves

