

316 SS FLOMAX 8

SELF PRIMING CENTRIFUGAL PUMPS

Features & Options

- 2" X 2" SELF PRIMING CENTRIFUGAL PUMP
- 316 STAINLESS STEEL
- PUMPAKS
- "C" FACE ELECTRIC MOTOR DRIVE
- FLOWS TO 140 GPM
- PRESSURES TO 100 FEET HEAD
- SEALS—STANDARD VITON OTHERS AVAILABLE (CONSULT FACTORY)
- OPTIONS: —ENGINE DRIVES
—PEDESTAL MODELS
—HYDRAULIC DRIVES
—CLUTCHPAKS

DIMENSIONS

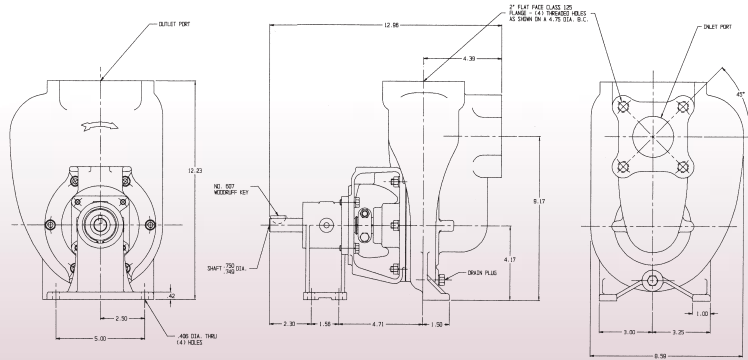

Pump Performance Curves

