

SERVICE MANUAL

MOYNO[®] Sanitary Pumps

FRAME TYPES:
FA-FB-FC-FBC

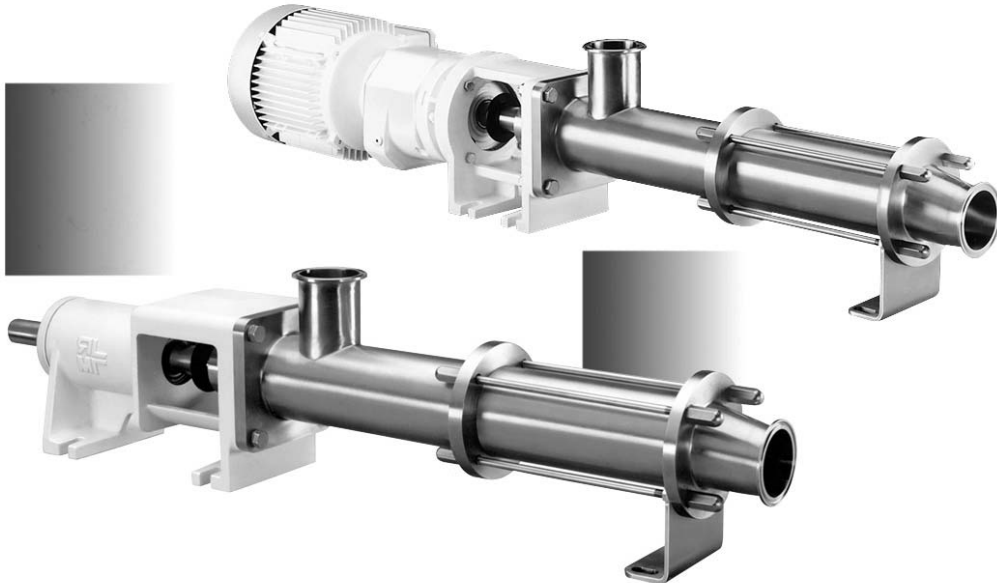

MOYNO

Always the Right Solution™

TABLE OF CONTENTS

	Page		Page
1.1. INTRODUCTION	1	4-12. CLEANING	6
1-2. GENERAL.....	1	4-13. INSPECTION.....	6
1-3. NAMEPLATE DATA	1	4-14. Bearings	6
1-4. Pump Rotation.....	1	4-15. Drive Shaft.....	6
1-5. Model Number.....	1	4-16. Seals	6
1-6. Frame Designation	1	4-17. Packing/Seal.....	6
1-7. Type Designation.....	1	4-18. Rotor.....	6
1-8. Trim Code	2	4-19. Stator.....	7
2-1. INSTALLATION	2	4-20. ASSEMBLY	7
2-2. GENERAL.....	2	4-21. Lubrication During Assembly.....	7
2-3. PIPING	2	4-22. Packing Installation	7
2-4. Suction Piping	2	4-23. Drive Shaft Assembly.....	7
2-5. Discharge Piping	2	4-23a. Ball Bearing Models.....	7
2-6. FOUNDATION.....	2	4-23b. Tapered Roller Bearing Models	7
2-7. SHAFT ALIGNMENT	3	4-23c. Close-Coupled Models.....	8
2-8. On Coupling Connected Units.....	3	4-23d. Adjusting Bearing End Play	8
2-9. On Belt Drive Units	3	4-24. Rotor, Connecting Rod and Intermediate Drive Shaft Assembly	8
2-10. WATER FLUSH OF PACKING	3	4-25. Rotor, Connecting Rod and Intermediate Drive Shaft Installation.....	8
2-11. SHAFT BEARING.....	3	4-26. Mechanical Seal Installation	8
2-12. CLEAN-IN-PLACE (CIP) OPTION	3	4-27. Stator Installation	8
3-1. OPERATION	4	4-28. Reconnect Pump	9
3-2. INITIAL CHECK.....	4	4-29. STORAGE	9
3-3. STARTUP	4	4-30. Short-Term Storage	9
3-4. PACKING LEAKAGE.....	4	4-31. Long-Term Storage.....	9
4-1. MAINTENANCE	4	4-32. VARIATIONS OF STANDARD PARTS.....	9
4-2. GENERAL.....	4	4-33. Trim Code	9
4-3. PACKING ADJUSTMENT.....	4	4-34. Packing.....	9
4-4. PACKING REPLACEMENT	5	4-35. Rotors.....	9
4-5. DISASSEMBLY	5	4-36. Drive Shaft.....	9
4-6. Disconnect Pump	5	4-37. REPLACEMENT PARTS	10,11
4-7. Packing Removal.....	5	4-38. PARTS LIST	12-17
4-8. Stator Removal.....	5		
4-9. Rotor and/or Drive Train Removal	5		
4-10. Rotor, Connecting Rod and Intermediate Drive Shaft Disassembly. 6			
4-11. Drive Shaft and Bearings Removal/ BareShaft Models.....	6		



Always the Right Solution™

Section:
MOYNO SANITARY PUMPS
(FA, FB, FC & FBC)
Page: 1
Date: December 15, 1996

SERVICE MANUAL
MOYNO® SANITARY PUMPS

1-1. INTRODUCTION

1-2. GENERAL

The Moyno Pump is one of the most versatile pumps available. It has been proven in thousands of applications over the past 60 years and is backed by the experience gained during these years, both in application and manufacturing know-how.

The Moyno Pump is a progressing cavity pump. The pumping action is created by the single helical rotor rolling eccentrically in the double threaded helix of the stator. In its revolution, the rotor forms in conjunction with the stator a series of sealed cavities 180 degrees apart. As the rotor turns, the cavities progress from the suction to the discharge end of the pump. As one cavity diminishes, the opposing cavity increases at exactly the same rate. Thus the sum of the two discharges is a constant volume. The result is a pulsation-free positive displacement flow with no valves.

The Moyno Sanitary Pump design, combined with the effective progressing cavity pumping principle, enables the food, chemical and pharmaceutical processing industries to comply with 3A sanitation requirements (mechanical seal required; pumps with packing do not meet 3A approval). The standard sanitary flanged and gasketed clamp-style connections on the suction and discharge ports and the open throat design permit the Moyno Sanitary Pump to pump fluids with diverse handling characteristics. Easy disassembly of pumping elements, accomplished in a few short minutes, provides for quick cleanup between "lot" processing, line changeovers and shutdowns. An optional clean-in-place (CIP) capability enables the Moyno Sanitary Pump to be cleaned without being disassembled.

1-3. NAMEPLATE DATA

The pump nameplate, located on the bearing housing, contains important information relating to the operation and servicing of the pump. This information includes the direction of rotation arrow and the pump model and serial numbers (see Fig. 1-1).

The pump model number must be used for reference when ordering spare parts. Please carefully file this manual for further reference.

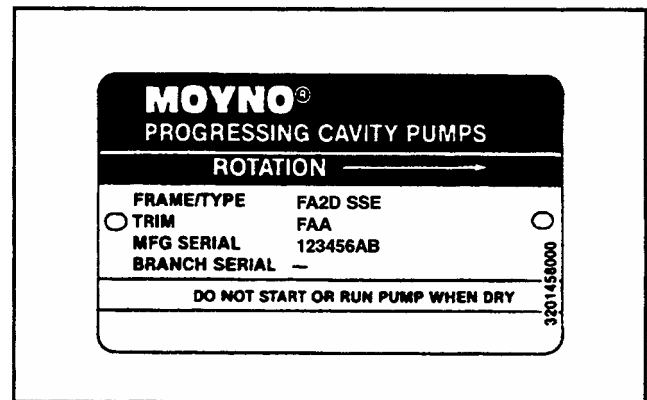

Figure 1-1. Typical nameplate showing rotation arrow, model and manufacturing serial numbers.

1-4. Pump Rotation. The direction of rotation is indicated by a rotation arrow on the nameplate. Normal rotation of Moyno Sanitary Pumps is clockwise when viewed from the driven end of the pump.

1-5. Model Number. The pump model number consists of three component parts: frame designations, type designations and a trim code. A typical model number might be FA2D SSE FAA, as shown on the nameplate in Fig. 1-1.

1-6. Frame Designation. The frame designation consists of four to five characters (e.g., FA2D) sequenced to provide identification of the type of frame, number of stages and element size of the pump.

The number in the frame designation always indicates the number of stages of the pumping elements.

Normally, the first character is the letter F, designating the pump as being the sanitary type. A "C" preceding the "F" would indicate a clean-in-place (CIP) option. The next letter indicates the drive end configuration: A-bare shaft, B-close-coupled, C-open throat, and BC-close-coupled open throat. The last letter indicates the pump capacity.

1-7. Type Designation. Following the frame designation is the type designation, a series of three letters describing the materials from which the pump is constructed (e.g., FA2D SSE).

The first letter identifies the material of the wetted housings.

The second letter identifies the material used in the drive shaft, connecting rod, rotor and other wettable parts.

The third letter identifies the material of the stator. It identifies only the stator material and not the tube in which the stator is placed; the tube is stainless steel.

A typical type designation such as SSE would result in the following:

- S = Stainless steel, type #304 suction housing
- S = Stainless steel, type #316 or 17-4 PH internals including drive shaft, pins, connecting rod, rotor, and other minor metallic parts in contact with the material being pumped
- E = Nitrile rubber stator (70 durometer; food grade)

The following letters identify the actual materials that are used in standard construction:

- FDA food grade
 - B--EPDM
 - E-- Nitrile
 - S -- Stainless steel
 - V -- Fluoroelastomer
- Non-food grade
 - 0-- Nitrile
 - F -- Fluoroelastomer
 - A -- Natural Rubber
 - Z -- Nitrile (white)

1-8. Trim Code. Also included in the nameplate is the three-character trim code designation. The first letter identifies sealing methods, the second character identifies internal variations and the third letter identifies rotor variations. Consult Section 4-33 for a further explanation of trim code.

2-1. INSTALLATION

2-2. GENERAL

Moyno Pumps are lubricated and tested at the factory prior to shipment and require minimum pre-startup maintenance.

Accessibility to the pump and adequate clearance should be a prime consideration in any installation. Enough space should surround the unit so that pump maintenance can be carried out with ease.

2-3. PIPING

2-4. Suction piping should be as short as possible. Normally, the suction line should be the same size as the pump suction. However, conditions such as high viscosity or required minimum flow velocities may dictate otherwise. Long-sweep 90-degree elbows or 45-degree elbows should be used instead of the standard elbow. Suction piping loops which trap air should be avoided.

2-5. Discharge piping diameter should generally be as large as the pump port unless fluids conditions indicate otherwise.

An easily removable section of piping one to two times longer than the stator (see the following chart) should be mated to the discharge port. This will allow the rotor and stator to be removed without having to completely remove the pump from the base.

Pump	Suggested Discharge Piping Lengths and/or Clearance	Minimum Discharge Piping Lengths and/or Clearance Without Removing Suction Housing
	INCHES (MM)	INCHES (MM)
FA2A	13.25 (335)	13.25 (335)
FA4A	13.25 (335)	13.25 (335)
FA1B	13.25 (335)	13.25 (335)
FA2B	13.25 (335)	13.25 (335)
FA4B	18.25 (465)	13.25 (335)
FA1C	15.25 (385)	15.25 (385)
FA2C	15.25 (385)	15.25 (385)
FA4C	21.25 (540)	15.25 (385)
FA1D	17.00 (430)	17.00 (430)
FA2D	17.00 (430)	17.00 (430)
FA4D	28.25 (720)	17.00 (430)
FA1E	19.00 (485)	19.00 (485)
FA2E	19.00 (485)	19.00 (485)
FA4E	35.50 (900)	19.00 (485)
FA1F	24.75 (625)	24.75 (625)
FA2F	24.75 (625)	24.75 (625)
FA4F	44.50 (1130)	24.75 (625)
FA1G	29.00 (735)	29.00 (735)
FA2G	29.00 (735)	29.00 (735)
FA1H	31.25 (795)	31.25 (795)
FA2H	31.25 (795)	31.25 (795)
FA1J	31.25 (795)	31.25 (795)
FA2J	39.50 (1005)	31.25 (795)
FA1K	31.25 (795)	31.25 (795)
FA2K	53.00 (1350)	31.25 (795)

2-6. FOUNDATION

For maximum pump-driver life, each unit should be mounted on a strong, fabricated stainless steel base plate which can be ordered from Moyno. The base plate should be mounted on a concrete foundation built on a solid base. The foundation should be approximately 4" (100mm) longer and wider than the base on which it is built (see Fig. 2-1) and should be an overall size of 4" (100mm) to 8" (200mm) larger than the base plate once it is mounted. Anchor bolts for the base plate should be located in the foundation.

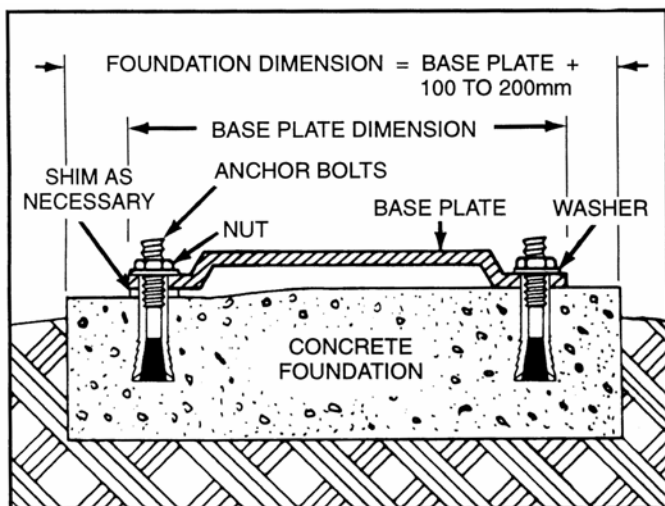

Figure 2-1. Typical Foundation Example

Check the base plate surface with a carpenter's level and place shims under the base plate at the places necessary to make it level. Then check the pump driver shafts and the pump ports to ensure that they are level. Complete base mounted units supplied by Moyno, including pump driver, are leveled with respect to the base at the factory. Shifting may occur during shipment. The pump and driver should be realigned. Care should be exercised to ensure that all components are level and mounted in a direct line.

For maximum rigidity and lower noise levels, the base plate should be grouted to the foundation after the anchor bolts have been evenly tightened. A good grade of nonshrink grout is recommended. The spaces between the base plate and the foundation around the shims and inside the bushings for the anchor bolts should also be filled with grout. Allow the grout to dry according to manufacturer's instructions. Then fully tighten the anchor bolts.

2-7. SHAFT ALIGNMENT

Although the base mounted units supplied by Moyno are leveled with respect to the base before shipping, most of the larger pump and driver units are shipped with the flexible coupling disconnected.

After the base has been bolted down to the foundation, check the following conditions:

2-8. On coupling connected units, be sure that the pump and driver shafts are realigned before the coupling is connected. Care should be exercised to ensure that all components are level and mounted in a direct line.

Check the gap between coupling halves (refer to the coupling manufacturer's recommendations). Adjustment can usually be accomplished by loosening the mounting bolts on either the pump or driver and moving the loosened component into alignment with the fixed component. On couplings with equal diameter hubs, it may be helpful to lay a straightedge axially across the coupling halves to check the alignment.

2-9. On belt drive units, check to ensure that sheaves or sprockets are in alignment. Check belts for proper tension. Tension requirements will vary with the type of belt, center distances and belt speeds. Consult the belt manufacturer for specific recommendations.

2-10. WATER FLUSH OF PACKING

Pumps with packing may be either grease lubricated through a grease fitting in the packing retainer or have lumbing connected to the housing to allow a water flush.

When the material being pumped is abrasive in nature, it may be advantageous to flush the packing to prevent excessive shaft wear.

Clean water can be injected through a 1/8" NPT tapped hole that normally houses the grease fitting for lubricating the packing. The water can be permitted to leak axially along the shaft and be removed from the second tapped hole in the packing retainer. The discharge from the packing retainer should be throttled slightly to maintain a 10 to 15 psi higher pressure in the packing retainer than is present in the suction housing (see Fig. 2-2).

If mechanical seals are to be used on the unit, consult the seal manufacturer's instructions for seal flush requirements.

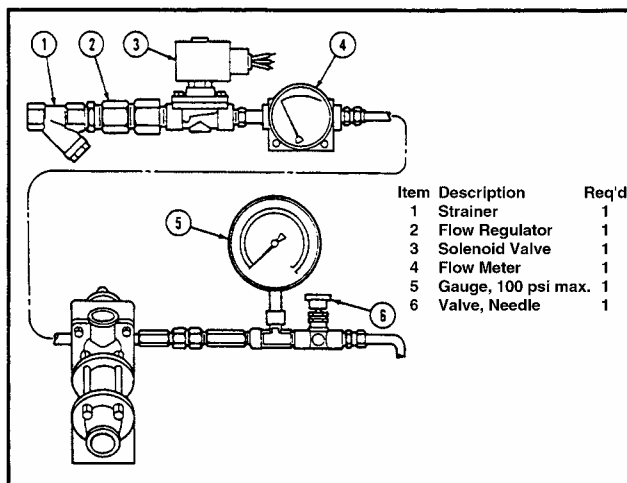

Figure 2-2. Typical Water Flush Arrangement

2-11. SHAFT BEARING

The bearings are lubricated at the factory and will only need to be relubricated when the shaft/bearing assembly is completely removed from the pump.

2-12. CLEAN-IN-PLACE (CIP) OPTION

The Moyno Sanitary Pump can be customized with a suction housing equipped for clean-in-place (CIP) operations. On a pump with the CIP option, an additional port in the suction housing permits a CIP bypass hookup. This bypass allows an extremely high rate of water to be supplied to the pump to create a turbulent condition which cleans pump parts such as flexible joints. Excess water passes through the bypass to the discharge line.

Two close-coupled valves should be installed in the bypass line, one at each end of the line, to close off the bypass during normal pumping operations. One of the valves should be a three-way valve so that one port is open to the atmosphere for drainage when the valves are closed.

Note: Moyno pumps require mechanical seals to meet 3A requirements.

3-1. OPERATION

3-2. INITIAL CHECK

Before putting the pump into operation, the following items should be checked to ensure that each piece of equipment is installed correctly:

- Pump, driver, coupling or sheave alignment
- Electrical connections
- Gauges and other instruments
- Water flush connection
- Pump rotation (normal rotation is indicated on the pump drive end)
- Belt tension on belt driven units (there should be no appreciable deflection when first starting up)
- Suction and discharge valves (both valves should be open)

CAUTION: This is a positive displacement pump. Do not operate it against a closed valve.

3-3. STARTUP

CAUTION: DRY OPERATION IS HARMFUL TO THE PUMP! Never allow the pump to operate without liquid as dry operation will cause premature wear of the stator and possible damage. The stator is lubricated by the liquid which is pumped.

1. In suction lift applications: Before operating the pump for the first time, fill it with liquid. If the liquid to be pumped is highly viscous, dilute it before filling the pump. The liquid fill-up will lubricate the stator for the initial startup.

Note: If the pump is shut down temporarily, enough liquid will remain in the system to provide lubrication upon restarting. It is advisable to maintain the suction piping at a higher elevation than the center line of the pump in order to contain some liquid in the pump at the time of the shutdown.

2. Once the pump has been filled with liquid, check the direction of the pump rotation by momentarily starting and stopping the drive. Check the rotation arrow on the pump nameplate for correct rotation.

3. In suction lift applications: When water flush is not utilized, it may be necessary to replace the zerk fitting at the packing retainer (in the suction housing) with a pipe plug to prevent loss of prime due to air leakage.

- 4. If applicable, turn on the seal water to the packing.
- 5. Start the pump.

3-4. PACKING LEAKAGE

A packing retainer is designed to control leakage, not stop it completely. Leakage is generally necessary to reduce friction and dissipate heat. The amount of leakage necessary will depend on the fluid pumped, the installation, and the pump speed and type. Refer to Section 4-3 for packing adjustment.

Moyno Sanitary Pumps have been designed for minimum packing retainer leakage when properly maintained. If leakage cannot be tolerated, a mechanical seal should be used.

4-1. MAINTENANCE

Note: In this section, the first reference to each pump part will be followed by a number or a letter in parentheses (). These numbers and letters identify the pump parts and hardware items in the cutaway view (Pgs.10-11).

4-2. GENERAL

The Moyno Sanitary Pump has been designed for a minimum of maintenance. It is only necessary to routinely adjust and lubricate the packing. Shaft bearings do not require periodic lubrication.

It is good practice to periodically touch the bearing housing to become familiar with the normal operating temperature of the bearings. If there is a sudden, rapid rise in operating temperature, remove the drive shaft and shaft bearings from the bearing housing and either clean and relubricate the bearings or replace them.

Inspect and either clean and relubricate or replace the shaft bearings every 8,000 to 10,000 operating hours.

4-3. PACKING ADJUSTMENT

Packing gland nuts should be evenly adjusted so they are little more than finger tight. Overtightening of the packing gland may result in premature packing failure and possible damage to the drive shaft and gland.

When packing is new, frequent minor adjustments during the first few hours of operation are recommended in order to compress and seat the packing (see Fig. 4-1).

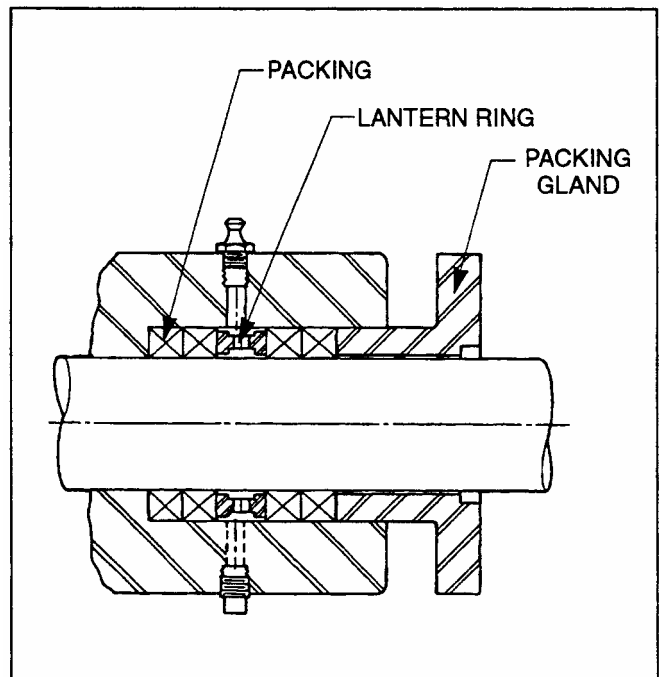

Figure 4-1. Cross Section of Packing Retainer

1. Upon initial startup of the pump, adjust the gland nuts (0950) for a leakage rate of 1 to 2 drops per second until the packing (6900) has seated and adjusted to the operating temperature (approximately 10 to 15 minutes).

2. If there is excessive leakage from the stuffing box (1000) after 15 minutes of operation, tighten the gland nuts until a desired leakage rate is obtained.

CAUTION: Do not tighten until zero leakage is obtained. Overtightening of the packing gland may result in accelerated wear on the packing and damage to the shaft. In those situations where no packing leakage can be tolerated, consult your Moyno authorized service representative.

4-4. PACKING REPLACEMENT

When leakage can no longer be regulated by tightening the gland nuts, remove and replace the packing. The entire pump need not be disassembled to replace the packing. Briefly, replace the packing as follows:

1. Remove the gland nuts (0950) and packing gland (0900) from the stuffing box.
2. Use a pair of packing extractors (Fig. 4-2) to remove the first two packing rings (6900), the lantern rings (6850) and the last two packing rings.



Figure 4-2. Packing Removal Tool

3. Inspect the surface of the drive shaft (6000) for excessive wear or grooves due to packing rub. If the shaft is worn, or is badly scored or grooved, it should be replaced.

4. If the drive shaft is not worn, lubricate the 4 new packing rings with a good grade of packing grease (see Section 4-21).

5. Insert two rings of packing, the lantern ring halves (with flat sides facing packing) and the remaining two packing rings onto the shaft. Tamp each ring into the packing retainer with the packing gland. Be sure to stagger the packing ring joints at 90-degree increments (see Section 4-22).

A fifth packing ring may fit into the packing retainer. As the pump operates, the packing will compress and the fifth packing ring can be added.

6. Position the packing gland on the gland studs and secure with the gland nuts. Tighten the nuts evenly but only tight enough to seat packing and provide a good seal. Overtightening will cause failure of the packing and shaft by overheating.

7. Adjust the packing per Section 4-3.

4-5. DISASSEMBLY

Note: The following instructions cover **one** procedure for disassembling all pump components. Major pump components can be disassembled in various ways since specific installation location limitations will determine the method of component removal.

4-6. Disconnect Pump

1. Operate the pump (preferably with clean water) to ensure that the rotor and stator are not dry.
2. Shut off the pump.
3. Close the suction and discharge valves.
4. If applicable, turn off the flush water to the packing or mechanical seal.
5. Disconnect the power source.

4-7. Packing Removal

1. Stop the pump.
2. Complete Section 4-6, steps 3 through 5.
3. Complete Section 4-4, steps 1 through 3.

4-8. Stator Removal

1. Complete Section 4-6.
2. If applicable and necessary, remove the clean-in place (CIP) pipe and valves.
3. Remove the section of discharge pipe attached to the reducer.
4. Remove the tie rod nuts (7100).
5. Slide tie rod (1300) back to clear end of stator (6500) or remove if necessary.
6. Pull the reducer from the end of the stator and pull the stator from the rotor (5000); then remove the gaskets (1200) from the reducer (1400) and suction housing (1100).

Note: To assist with the removal of the stator on larger pumps, slide the pull-out sleeve over the end of the stator. Align the threaded holes in the sleeve with the pilot holes in the stator and insert the two pull-out rods. With the rod tips seated in the pilot holes in the stator, grip the rods to twist and pull the stator from the rotor.

7. Inspect the stator for wear (see Section 4-19).

4-9. Rotor and/or Drive Train Removal

1. Complete Sections 4-6 and 4-8.

Note: Skip step 2 and proceed with step 3 if the Sanitary Pump is equipped with a mechanical seal.

2. Loosen the packing gland nuts on the gland studs.
3. At the drive shaft end of the pump, slide the rubber slinger/pin retainer to expose the drive pin.
4. Remove the pin (2000) from the drive shaft, using a small punch, if necessary.
5. Pull the rotor, connecting rod (6200) and intermediate (2100) or close-coupled drive shaft (6000) as a unit from the housings.

Note: If end clearance is not available to pull this unit in one piece, disconnect the suction piping so that the suction housing and the stuffing box/seal housing can be removed with the rotor/intermediate drive shaft assembly and then separated.

6. Inspect the rotor for wear (see Section 4-18).

4-10. Rotor, Connecting Rod and Intermediate Drive Shaft Disassembly

1. Complete Sections 4-6, 4-8 and 4-9.

2. Unseat the snap rings (2300) at each end of the connecting rod and slide the snap rings and pin retainers (6100) onto the connecting rod.

3. Remove the pins (6300) and separate the rotor and intermediate drive shaft from the connecting rod. Remove the snap rings and pin retainers from the connecting rod.

4-11. Drive Shaft and Bearings Removal/Bare Shaft Models

1. Complete Sections 4-6, 4-8 and 4-9.

2. Disconnect and remove the pump driver and the drive coupling.

3. Unbolt the bearing cover plate (0300) from the bearing housing (0100) and remove the cover plate and grease seal (0600).

4. Pull or press the bearings (0400) and drive shaft from the bearing housing (0100).

5. Press bearings from the drive shaft removing the retaining rings (0450) and grease retainers (0500) to facilitate bearing removal.

6. Remove bearing housing retaining ring (0150), then remove the radial grease seal housing (0700) and bearing race from the bearing housing.

4-12. CLEANING

Clean all parts in a suitable cleaning solvent, being careful to observe all safety precautions regarding the use of solvent.

4-13. INSPECTION

4-14. Bearings. After cleaning, rotate the bearings slowly, feeling for smoothness and even action. Check for cracks, galling, pitting, burrs, etc. Replace bearings if there is any doubt concerning complete serviceability.

4-15. Drive Shaft. Inspect the drive shaft for scoring, burrs, cracks, etc. Replace as necessary.

4-16. Seals. It is good practice to always replace grease seals whenever the drive shaft and the bearings are removed.

4-17. Packing/Seal. It is good practice to always replace packing or mechanical seal (6950) whenever the pump bearing housing is disassembled.

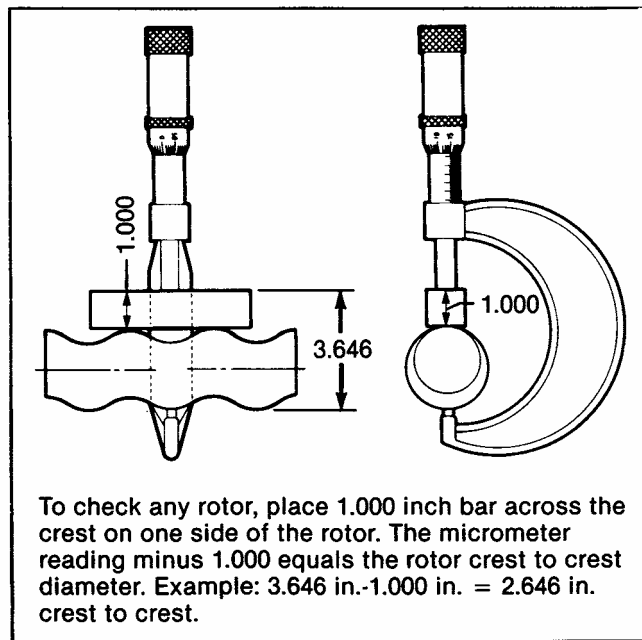

To check any rotor, place 1.000 inch bar across the crest on one side of the rotor. The micrometer reading minus 1.000 equals the rotor crest to crest diameter. Example: 3.646 in.-1.000 in. = 2.646 in. crest to crest.

Figure 4-3. Measuring Rotor Dimension

4-18. Rotor

1. To check for excessive wear of the rotor, measure the rotor crest-to-crest diameter (see Fig. 4-3) and compare it with the following chart.

Rotor Size	*Standard Crest-to-Crest Diameter	
	Inches	(MM)
A	.886	(22.504)
B	1.061	(26.95)
C	1.327	(33.71)
D	1.671	(42.44)
E	2.100	(53.34)
F	2.676	(67.97)
G	3.428	(87.07)
H,J,K	4.015	(101.98)

*These dimensions are applicable for FAA and SAA trim codes only.

2. If the measured crest-to-crest diameter is within 0.010" (.25mm) of the standard value and is free of deep nicks, gouges or other surface defects, the rotor is reusable.

3. Rotors with crest-to-crest values 0.011" (.28mm) to 0.050" (1.3mm) under the standard values should be replaced. These rotors can be renewed by chrome plating to standard dimensions provided that:

- a. the pin holes are not excessively worn.
- b. the rotor surface is not cracked, pitted or deeply grooved 1/32" (.8mm) or more.
- c. the base metal surface is not pitted or corroded.

4. Rotors may be sent to Moyno for replating. Rotors should be stripped and replated to standard dimensions, then buffed.

4-19. Stator. A worn stator may appear pitted and gouged, or it may appear smooth similar to when it was new. Performance is the best measure of rotor-to-stator fit. If you are unable to measure performance adequately, suspected stator wear can be evaluated by a Moyno sales or factory representative.

4-20. ASSEMBLY

Moyno Sanitary Pumps are reassembled in reverse order of dismantling. The following suggestions are offered:

1. While the pump is dismantled, check all O-rings, packing and snap rings. Replace all worn parts.

2. During the assembly process, cleanliness is important. To avoid premature failure, all components must be handled with care and kept clean.

4-21. Lubrication During Assembly

1. Bearings. Pack the bearings prior to assembly into the bearing housing. Lubricant should completely cover the faces of the bearing races.

2. Packing. Lubricate the packing rings during assembly. Additional grease can be added after assembly through the zerk fitting in the packing retainer.

3. Approved lubricants:

CAUTION: Do not mix different brands of lubricants.

Area to Lubricate	Approved Lubricant or Equivalent
Bearings	Mobilux EP2 Grease (Mobil Chemical Co.)
Packing	FGG 2 Grease (Dubois Chemical)

4-22. Packing Installation

1. The standard packing set consists of five packing rings and two Teflon lantern ring halves.

2. Install packing and lantern ring halves into the stuffing box in the following sequence:

a. Wipe a film of lubricant on each packing ring and install two rings. Push each ring firmly in place.

Note: Install the packing rings with the splits staggered at 90 degrees to the adjacent ring of packing.

CAUTION: Always use the packing gland or a proper packing tamper tool to install the packing. Do not use a pointed or sharp tool, as damage to the packing material or drive shaft could result. To assure proper shaft lubrication, never use a one-piece spiral wrap packing.

b. Install the two lantern ring halves with the flat sides against the packing.

c. Install the final three packing rings, firmly pushing each ring into place.

Note: On initial assembly, one ring of packing may not fit into the packing retainer. This final ring of packing should be installed after the pump has been started and packing is seated.

3. Install the packing gland and gland nuts. Tighten the nuts finger tight at this time.

4-23. Drive Shaft Assembly

4-23a. Ball Bearing Models

1) Press sealed bearing (0400) on drive shaft.

2) Install shaft snap ring (0450) in groove on shaft. Seat bearing against snap ring.

3) Install second shaft snap ring.

4) Press second sealed bearing on shaft and seat against snap ring.

5) If not already in place, install bearing housing snap ring (0150) in groove inside stuffing box end of bearing housing.

6) Place assembled drive shaft into bearing housing. Secure by inserting second bearing housing snap ring in groove in drive end of bearing housing.

4-23b. Tapered Roller Bearing Models

1) Install bearing housing retaining ring in bearing housing groove.

2) Press grease seal (0600) into grease seal housing (0700) and assemble in housing with chamfered side of grease seal housing facing bearing location.

3) Slide bearing cup into the bearing housing against the seal housing.

4) Press bearing cone on shaft approximately .150" beyond snap ring groove.

5) Place grease retainer (0500) on shaft and install shaft snap ring in groove on shaft.

6) Seat bearing and grease retainer against snap ring.

7) Install second shaft snap ring in groove on shaft and place second grease retainer on shaft.

8) Press bearing cone on shaft, and seat bearing and grease retainer against snap ring.

9) Fill grease seal housing with grease.

10) Slide drive shaft assembly into bearing housing.

11) Fill area around the bearing in the drive end of the bearing housing with grease.

12) Complete bearing assembly by sliding bearing cup into bearing housing.

13) Press grease seal in bearing cover (0300) and place bearing cover on shaft. Secure with bearing cover screws and lock washers. (See Section 4-23D.)

4-23c. Close-Coupled Models

- 1) Place slinger/retaining ring (6800) on drive shaft.
- 2) Mount drive to the drive adaptor (0100) using four bolts, lock washers, and nuts.
- 3) Install drive shaft assembly into the drive adaptor while coupling drive shaft to output shaft of drive.
- 4) Install the drive pin in the hole in the drive shaft, locking the drive shaft to the reducer shaft.
- 5) Slide the rubber pin retainer over the pin.

4-23d. Adjusting Bearing End Play (Tapered Roller Bearings Only)

1. Tighten bearing cover screws around bearing cover firmly, to the point the shaft will not turn. (Screws should be tightened evenly, opposite each other).
2. Measure the gap between the bearing cover and the bearing housing.
3. Remove bearing cover and add shims (6700) to equal gap measured in step 2 plus an additional .002 to .006 inch.
4. Install bearing cover with shims and tighten screws evenly, opposite each other.
5. Tap lightly on the shaft head using a soft mallet. Rotate shaft to "free up" assembly. You should be able to rotate the shaft by hand, with moderate resistance.
6. Shims may be added or subtracted to get the proper setting.

4-24. Rotor, Connecting Rod and Intermediate Drive Shaft Assembly

1. Place one snap ring and one pin retainer over one end of the connecting rod.
2. Insert the connecting rod end into the bore of the rotor, aligning the pin holes and inserting a lightly lubricated pin.
3. Slide the pin retainer over the pin and seat the snap ring in the groove on the rotor.

Note: Two sets of holes are provided in the rotor and the intermediate drive shaft. Should one set of holes become elongated by wear, rotate the parts to align the connecting rod hole with the unused holes.

4. Assemble the connecting rod and rotor assembly to the intermediate drive shaft in the same manner.

4.25. Rotor, Connecting Rod and Intermediate Drive Shaft Installation (Mechanical Seal Pumps Proceed to 4-26)

1. Position the packing in the stuffing box as described in 4-22, and install the gland studs, if removed.
2. Position the stuffing box in the bearing housing, sliding the packing gland on packed models onto the gland studs. Rotate the stuffing box so that the zerk fitting (not shown) is on the side.

3. Install the intermediate shaft seal ring (2200) on the intermediate shaft.

4. Insert the rotor-rod-shaft assembly through the stuffing box, seating the end of the intermediate drive shaft into the drive shaft. Rotate the shafts to align the pin holes and insert the pin.

5. Position the suction housing on the bearing housing, engaging the gasket (1220) on the end of the stuffing box.

6. Slide the rubber pin retainer in place on the drive shaft over the pin.

4-26. Mechanical Seal Installation

1. Complete Sections 4-20, 4-21, 4-23 and 4-24.
2. Install the stationary component (carbon and O-ring) of mechanical seal (6950) in seat of seal retainer (1000).
3. Position the seal housing in the bearing housing (0100).
4. Slide the rotating component (spring and ceramic) onto the drive shaft so that the tab of the spring will fit into the slot in the intermediate drive shaft. It may be necessary to wipe a small amount of lubricant around inside diameter of rotating component.
5. Position the suction housing (1100) on the bearing housing, engaging the gasket on the of the seal retainer.
6. Complete Section 4-25, steps 4 and 5, to reinstall the rotor, connecting rod and intermediate drive shaft. Care should be taken not to damage carbon stationary component of seal.

4-27. Stator Installation

1. Install the stator gaskets (1200) in the ends of the suction chamber and discharge flange.
2. Coat the inside of the stator (6500) and rotor (5000) with lubricant compatible both with the stator material and the material to be pumped.
3. Thread the stator onto the rotor and seat the stator into the suction housing.
4. Position the reducer (1400) on the end of the stator.

Note: If the pump is equipped with a pull-out sleeve and pullout rods, they may be used to assist in installing the stator into the rotor. Install the sleeve and rods as noted in Disassembly Section 4-8. When the stator is seated on the rotor, remove the rods and sleeve before installing the reducer.

5. Position the tie rods with the loosened clamp nut (behind the stator support) and fit into suction housing, the reducer, and stator support. Tighten the tie rod nuts sufficiently to seat and seal all gasket joints. Tighten the clamp nuts back against the stator support tightening to the discharge flange.

6. Install the section of discharge pipe that attaches to the reducer.

4-28. Reconnect Pump

1. If applicable, close the clean-in-place (CIP) valves.
2. If applicable, turn on the flush water to the packing or mechanical seal.
3. Open the suction and discharge valves.
4. Reconnect the power source.

4-29. STORAGE

4-30. Short-Term Storage. Storage of six months or less will not damage the sanitary type pump. However, to ensure the best possible protection, the following is advised.

1. Cover the pump with some type of protective covering. Do not allow moisture to collect around the pump.
2. Disassemble the pumping elements and thoroughly clean all components. Dry the components completely and reassemble.
3. Loosen the packing gland and inject a liberal amount of lubricant into the packing retainer. Tighten the packing gland only hand tight. When water flush systems are used, do not use grease. A small amount of light oil is recommended instead.
4. See drive manufacturer's instructions for motor and/or drive storage.
5. See OPERATION Sections 3-1 through 3-4 before startup. Be sure all lubricants are in good condition.

4-31. Long-Term Storage. If the pump is to be in storage for more than six months, perform the above short-term storage procedures plus the following:

1. Periodically, rotate the pump manually a few revolutions to avoid a "set" condition of the rotor in the stator elastomer. This will prevent hard starting and excessive torque requirements when the pump is again put in operation.
2. If applicable, remove drive belts.

4-32. VARIATIONS OF STANDARD PARTS

4-33. Trim Code. Also included on the nameplate is the three-part trim code which is used to identify pump construction. Each character of the trim code identifies a specific aspect of pump construction. The first character identifies *sealing* variations; the second, *internal* variations; the third, rotor variations.

- Sealing Variations:
 - D -- Double mechanical seal (optional).
 - F -- Braided Teflon food grade packing (white).
 - S -- Single mechanical seal.
 - X -- Special to application.

- Internal Variations:
 - A -- Standard plated shaft
 - B -- Non-plated shaft
 - G -- Ceramic coating
 - X -- Special to application

- Rotor Variations:
 - A -- Standard size with chrome plating
 - B -- Non-plated (no plating)
 - C -- Standard undersize
 - E -- Standard oversize
 - G -- Ceramic coating
 - X -- Special to application

The trim code SAA identifies a pump with a single mechanical seal. Deviations from standard are indicated by substituting the appropriate character from the list above. For example, the trim code FAA represents a pump with packed features. The trim code FBE identifies a pump with non-plated shaft and an oversized rotor.

When two or more characters are combined to identify a variation, the three parts of the trim code are separated by dashes. For example, the trim code F-A-EB identifies a pump with a non-plated, oversized rotor.

Single mechanical seals are standard.

4-34. Packing on all Moyno Sanitary Pumps consist of five solid braided Teflon packing rings and two Teflon lantern rings, with food grade lubricant or water flush (a pump with packing does not meet 3A approval). Double mechanical seals with or without water flush are available. Consult your Moyno representative.

4-35. Rotors identified on parts listing are standard size with hard chrome plated surface. Other variations of rotor size and material may be ordered by selecting the standard rotor part number and changing the last digits of the rotor number as follows:

015 = Standard size, chrome plated, 316SS
 152 = Undersize, chrome plated, 316 SS
 153 = Oversize, chrome plated, 316 SS
 017 = Standard size, chrome plated, 17-4 PH SS
 172 = Undersize, chrome plated, 17-4 PH SS
 173 = Oversize, chrome plated, 17-4 PH SS

Do not change rotor sizes without consulting your Moyno sales office. These variations are used for certain specialized pumping conditions only. Unplated rotors are available. Please consult factory.

4-36. Drive shaft shown has hard chrome plating on the packing wear area. If a nonplated drive shaft is required, consult the factory.

4-37. REPLACEMENT PARTS

A-MODELS BARE SHAFT

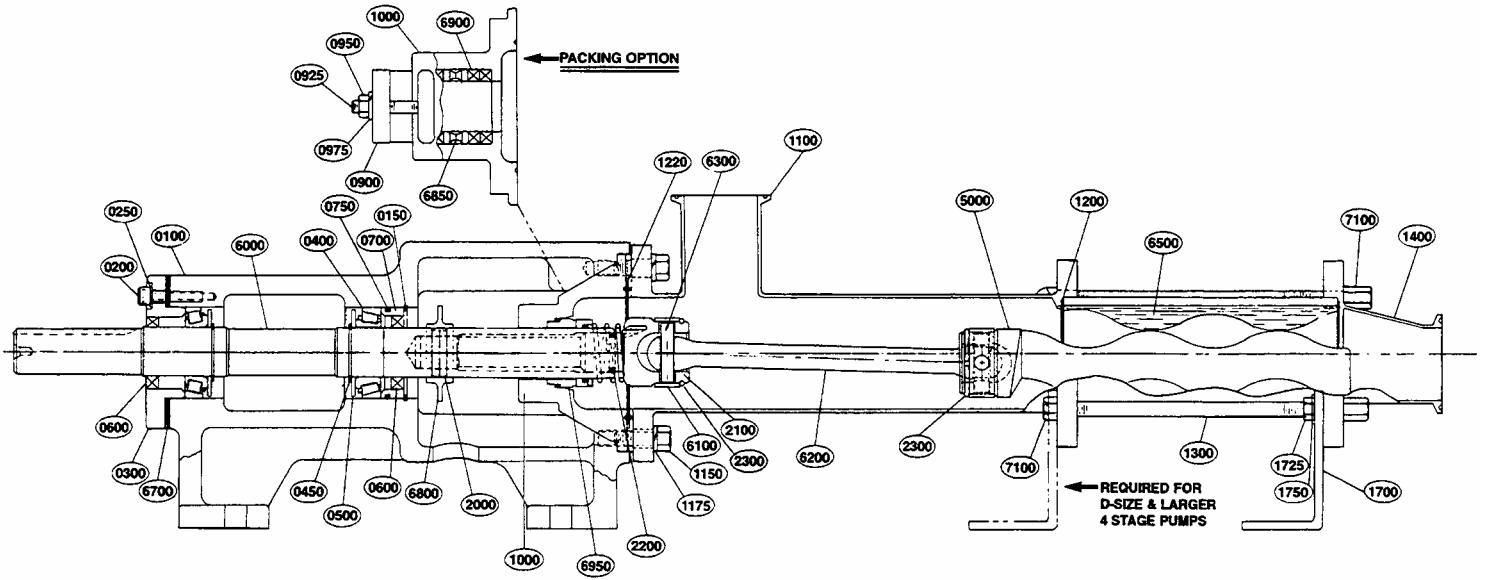

B-MODELS CLOSE-COUPLED

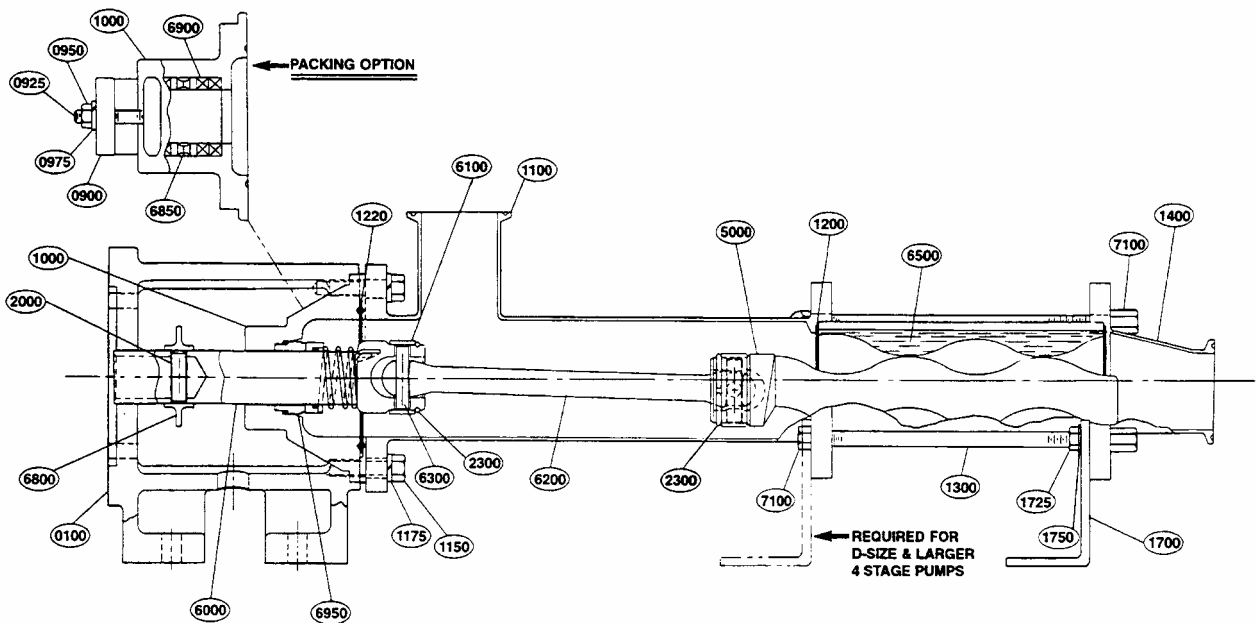

4-38. PARTS LIST

CODE	DESCRIPTION	REQ	A	B	C	D	E	F	G	H	J	K	
0100	BEARING HOUSING	1	4250184001			4250185001		4250186001		4250187001			
0100	CLO-CPL ADAPTER	1	4250417001 (140 MM FLANGE) 4250417002 (160 MM FLANGE)			4250418001		4250419001		4250373101 (250 MM FLANGE) 4250373102 (300 MM FLANGE)			
0150	RETAINING RING (REQ)	1	4220425001 (2)			4220425002		4220425003		4220425004			
0200	BOLT	4				4220208025		4220253030		4220253030 (6)			
0250	LOCK WASHER	4				4220212008		4220212010		4220212010 (6)			
0260	BOLT	4	4220210040						4220262055				
0270	NUT	4	4220357008						4220357012				
0280	LOCK WASHER	4	4220212008						4220212012				
0300	BEARING COVER	1				4240704001		4240706001		4240707001			
0400	BEARING	2	BD005			BL005		BL010		BL015			
0450	RETAINING RING	2	EB004			EB012		EB024		EB031			
0500	GREASE RETAINER	2				MS A1D0500		MS A1F0500		MS A1H0500			
0600	GREASE SEAL	2				4220401000		4220402000		4220403000 (1) 4220404000 (1)			
0700	GREASE SEAL HSG.	1				4230487001		4230488001		4230489001			
0750	GREASE SEAL HOUSING O-RING	1				3207902138		3207902234		3207902238			
0900	PACKING GLAND	1	4240452007			4240453007		4240454007		4240455007			
0925	PKG. GLAND STUD	2	4220416015			4220417015		4220418015					
0950	PKG. GLAND NUT	2	4220357006			4220357008		4220357010					
0975	LOCK WASHER	2	4220212006			4220212008		4220212010					
0980	PIPE PLUG	1	6100420010										
0985	GREASE FITTING	1	3207259001										
1000	MECH. SEAL HSG.	1	4240796015			4240797015	4240798015	4240733007		4240734007			
1000	STUFFING BOX	1	4240687007			4240689007	4240708007	4240691007		4240693007			

CODE	DESCRIPTION	A	B	C	D	E	F	G	H	J	K
1100	SUCTION HSG, QUICK CLAMP 425038-	2001	3001	4001	5001	6001	7001	8001	9001		
1100	SUCTION HSG, ACME 425049-	0001	1001	2001	3001	4001	5001	6001	7001		
1100	SUCTION HSG, OPEN THROAT 42504-	27001	28001	29001	30001	31001	32001	33001	34001		

PARTS LIST (Cont.)

CODE	DESCRIPTION	A	B	C	D	E	F	G	H	J	K
1100	SUCTION HSG, DIN 11851 FLANGE 42504-	35001	36001	37001	38001	39001	40001	41001		42001	
1100	SUCTION HSG WITH CIP PORT - QUICK CLAMP VERT, 42504-				70101	71101	72101	73101		74101	
1100*	SUCTION HSG WITH CIP PORT - QUICK CLAMP LEFT, 42504-	67201	68201	69201	70201	71201	72201	73201		74201	
1100*	SUCTION HSG WITH CIP PORT - QUICK CLAMP RIGHT, 42504-	67301	68301	69301	70301	71301	72301	73301		74301	
1100	SUCTION HSG WITH CIP PORT - DIN 11851 VERT, 42504-				78101	79101	80101	81101		82101	
1100*	SUCTION HSG WITH CIP PORT - DIN 11851 LEFT, 42504-	75201	76201	77201	78201	79201	80201	81201		82201	
1100*	SUCTION HSG WITH CIP PORT - DIN 11851 RIGHT, 42504-	75301	76301	77301	78301	79301	80301	81301		82301	

CODE	DESCRIPTION	REQ	A	B	C	D	E	F	G	H	J	K	
1125	NUT FOR SUCTION HSG. BOLT	4	4220357010						4220357016		4220357020		
1150	SUCTION HSG. BOLT CL0-CPL	4	4220274050						4220426065		4220427055		
1150	SUCTION HSG. BOLT BARE SHAFT	4	4220274030						4220426040		4220427055		
1175	LOCK WASHER	4	4220212010						4220212016		4220212020		

CODE	DESCRIPTION	A	B	C	D	E	F	G	H	J	K
1200	STATOR GASKETS NITRILE, 4230486-	101	102	103	104	105	106	107		108	
1200	STATOR GASKETS EPDM, 4230486-	301	302	303	304	305	306	307		308	
1200	STATOR GASKETS FLUOROELASTOMER 4230486-	501	502	503	504	505	506	507		508	
1220	SUCTION HSG GASKET NITRILE, 4240722-	101			102	103	104			105	
1220	SUCTION HSG GASKET EPDM, 4240722-	301			302	303	304			305	
1220	SUCTION HSG GASKET FLUOROELASTOMER, 4240722-	501			502	503	504			505	

*LEFT AND RIGHT WHEN VIEWED FROM DRIVE END OF PUMP

PARTS LIST (Cont.)

CODE	DESC	REQ	A	B	C	D	E	F	G	H	J	K
1300	TIE ROD 4240721- (STAGE)	4	001 (2) 002 (4)	003 (1) 004 (2) 005 (4)	006 (1) 007 (2) 008 (4)	009 (1) 010 (2) 011 (4)	012 (1) 013 (2) 014 (4)	015 (1) 016 (2) 017 (4)	018 (1) 019 (2)	021 (1) 022 (2)	024 (1) 025 (2)	026 (1) 027 (2)

CODE	DESCRIPTION	A	B	C	D	E	F	G	H
1400	DISCHARGE FLANGES (NO CIP PORTS), QUICK CLAMP, 4250-	399001	400001	401001	402001	403001	404001	405001	406001
1400	DISCHARGE FLANGES (NO CIP PORTS), ACME, 4250-	498001	499001	500001	501001	502001	503001	504001	505001
1400	DISCHARGE FLANGES (NO CIP PORTS) - DIN 11851 FLANGE, 4250-	443001	444001	445001	446001	447001	448001	449001	450001

CODE	DESCRIPTION	REQ	A	B	C	D	E	F	G	H	J	K
1700	STATOR SUPPORT	1	4240749001			4240750001 (2 REQ ON D & LARGER 4 STAGE PUMPS)	4240751001	4240752001	4240753001	4240754001 (2 REQ ON 2 STAGE J & K PUMPS)		
1725	NUT	2	4220357008			4220357010		4220357012		4220357016		
1750	LOCK WASHER	2	4220212008			4220212010 (4 REQ ON D & LARGER 4 STAGE PUMPS)		4220212012		4220212016		
2000	SHAFT PIN (BARE SHAFT)	1	4220412017			4220411017		4220410017		4220408017		
2000	SHAFT PIN (CLO- CPL)	1	4220412017			4220411017		4220410017		4220469017		

CODE	DESCRIPTION	REQ	A	B	C	D	E	F	G	H	J	K
2100	INTERMEDIATE DRIVE SHAFT 424069-	1	7017		9017							
2100	INTERMEDIATE DRIVE SHAFT 424070-	1				0017	1017	2017	3017	5017		
2200	SHAFT SEAL RING (FOOD GRADE NITRILE)	1	4230491101			4230491102		4230491103		4230491104		
2200	SHAFT SEAL RING (FOOD GRADE EPDM)	1	4230491301			4230491302		4230491303		4230491304		

PARTS LIST (Cont.)

CODE	DESCRIPTION	REQ	A	B	C	D	E	F	G	H	J	K
2200	SHAFT SEAL RING (FOOD GRADE FLUOROELASTOMER)	1	4230491501			4230491502		4230491503			4230491504	
2300	SANITARY SNAP RING	2	4220413000	3200359000	4220414000	3200307000	3205231000	3201719000	4220415000			

CODE	DESCRIPTION	A	B	C	D	E	F	G	H	J	K
5000	ROTOR, STD SIZE, 316 SS, 42503-(STAGE)	17015 (2) 19015 (4)	21015 (1) 23015 (2) 25015 (4)	27015 (1) 29015 (2) 31015 (4)	33015 (1) 35015 (2) 37015 (4)	39015 (1) 41015 (2) 43015 (4)	45015 (1) 47015 (2) 49015 (4)	51015 (1) 53015 (2)	57015 (1) 59015 (2)	63015 (1) 65015 (2)	67015 (1) 69015 (2)
5000	ROTOR, UNDERSIZE, 316 SS, 42503-	17152 (2) 19152 (4)	21152 (1) 23152 (2) 25152 (4)	27152 (1) 29152 (2) 31152 (4)	33152 (1) 35152 (2) 37152 (4)	39152 (1) 41152 (2) 43152 (4)	45152 (1) 47152 (2) 49152 (4)	51152 (1) 53152 (2)	57152 (1) 59152 (2)	63152 (1) 65152 (2)	67152 (1) 69152 (2)
5000	ROTOR, OVERSIZE, 316 SS, 42503-	17153 (2) 19153 (4)	21153 (1) 23153 (2) 25153 (4)	27153 (1) 29153 (2) 31153 (4)	33153 (1) 35153 (2) 37153 (4)	39153 (1) 41153 (2) 43153 (4)	45153 (1) 47153 (2) 49153 (4)	51153 (1) 53153 (2)	57153 (1) 59153 (2)	63153 (1) 65153 (2)	67153 (1) 69153 (2)
5000	ROTOR, STD SIZE, 17-4 PH SS HARDENED, 42503-	17017 (2) 19017 (4)	21017 (1) 23017 (2) 25017 (4)	27017 (1) 29017 (2) 31017 (4)	33017 (1) 35017 (2) 37017 (4)	39017 (1) 41017 (2) 43017 (4)	45017 (1) 47017 (2) 49017 (4)	51017 (1) 53017 (2)	57017 (1) 59017 (2)	63017 (1) 65017 (2)	67017 (1) 69017 (2)
5000	ROTOR, UNDERSIZE, 17-4 PH SS HARDENED, 42503-	17172 (2) 19172 (4)	21172 (1) 23172 (2) 25172 (4)	27172 (1) 29172 (2) 31172 (4)	33172 (1) 35172 (2) 37172 (4)	39172 (1) 41172 (2) 43172 (4)	45172 (1) 47172 (2) 49172 (4)	51172 (1) 53172 (2)	57172 (1) 59172 (2)	63172 (1) 65172 (2)	67172 (1) 69172 (2)
5000	ROTOR, OVERSIZE 17-4 PH SS HARDENED, 42503-	17173 (2) 19173 (4)	21173 (1) 23173 (2) 25173 (4)	27173 (1) 29173 (2) 31173 (4)	33173 (1) 35173 (2) 37173 (4)	39173 (1) 41173 (2) 43173 (4)	45173 (1) 47173 (2) 49173 (4)	51173 (1) 53173 (2)	57173 (1) 59173 (2)	63173 (1) 65173 (2)	67173 (1) 69173 (2)

CODE	DESCRIPTION	REQ	A	B	C	D	E	F	G	H	J	K
6000	BARE SHAFT PUMP DRIVE SHAFT	1	4250378015			4250379015		4250380015			4250381015	
6000	CC DRIVE SHAFT	1	4250421017	4250422017	4250423017	4250424017	4250425017	4250426017	4250485017 45MM BORE, 18MM PIN			
6100	PIN RETAINER	2	4220421015	3200360000	4220422015	3200308000	3205226000	3201715015	4220423015			
6200	CONNECTING ROD	1	4240714017	4240715017	4240716017	4240717017	4240718017	4240719017	4240720017			

CODE	DESCRIPTION	REQ	A	B	C	D	E	F	G	H	J	K
6200	CONNECTING ROD WITH AUGER FLIGHT 42504-	1	57017	58017	59017	60017	61017	62017	63017	64017	65017	

PARTS LIST (Cont.)

CODE	DESCRIPTION	REQ	A	B	C	D	E	F	G	H	J	K
6300	DRIVE PIN	2	4220429017		3207501017	4220430017	3207502017	3207503017	3201721017			4220498017

CODE	DESCRIPTION	A	B	C	D	E	F	G	H	J	K
6500	STATOR, NITRILE, 42504- (STAGE)	07102(2) 07104(4)	08101(1) 08102(2) 08104(4)	09101(1) 09102(2) 09104(4)	10101(1) 10102(2) 10104(4)	11101(1) 11102(2) 11104(4)	12101(1) 12102(2) 12104(4)	13101 (1) 13102 (2)	14101(1) 14102(2)	15101(1) 15102(2)	16101(1) 16102(2)
6500	STATOR, NATURAL, 42504-	07202(2) 07204(4)	08201(1) 08202(2) 08204(4)	09201(1) 09202(2) 09204(4)	10201(1) 10202(2) 10204(4)	11201(1) 11202(2) 11204(4)	12201(1) 12202(2) 12204(4)	13201 (1) 13202 (2)	14201(1) 14202(2)	15201(1) 15202(2)	16201(1) 16202(2)
6500	STATOR, EPDM, 42504-	07302(2) 07304(4)	08301(1) 08302(2) 08304(4)	09301(1) 09302(2) 09304(4)	10301(1) 10302(2) 10304(4)	11301(1) 11302(2) 11304(4)	12301(1) 12302(2) 12304(4)	13301(1) 13302(2) 13304(4)	14301(1) 14302(2) 14304(4)	15301(1) 15302(2) 15304(4)	16301(1) 16302(2) 16304(4)
6500	STATOR, FLUORO-ELASTOMER, 42504-	07502(2) 07504(4)	08501(1) 08502(2) 08504(4)	09501(1) 09502(2) 09504(4)	10501(1) 10502(2) 10504(4)	11501(1) 11502(2) 11504(4)	12501(1) 12502(2) 12504(4)	13501 (1) 13502 (2)	14501(1) 14502(2)	15501(1) 15502(2)	16501(1) 16502(2)
6500	STATOR, WHITE NITRILE, 42505-	06102(2) 06104(4)	07101(1) 07102(2) 07104(4)	08101(1) 08102(2) 08104(4)	09101(1) 09102(2) 09104(4)	10101(1) 10102(2) 10104(4)	11101(1) 11102(2) 11104(4)	12101 (1) 12102 (2)	13101(1) 13102(2)	14101(1) 14102(2)	15101(1) 15102(2)

CODE	DESCRIPTION	REQ	A	B	C	D	E	F	G	H	J	K
6700	BEARING SHIMS	1				GP A1D6700		GP A1F6700				GP A1H6700
6800	SLINGER/PIN RETAINER	1		4230528000		4230529000		4230530000				4230531000
6850	LANTERN RING	1		4230482001		4230482002		4230482003				4230482004
6900	PACKING	1		3403656001		3403656002		3403656003				3403656004
6950	MECH SEAL, FDA NITRILE CW OR STD ROTATION	1		4220434000		4220435000		4220436000				4220437000
6950	MECH SEAL, FDA NITRILE, CCW OR REVERSE ROTATION	1		4220438000		4220439000		4220440000				4220441000
6950	MECH SEAL, FDA EPDM, CW OR STD ROTATION	1		4220461000		4220462000		4220463000				4220464000
6950	MECH SEAL, FDA EPDM, CCW OR REVERSE ROTATION	1		4220465000		4220466000		4220467000				4220468000
6950	MECH SEAL, FDA FLUORO, CW OR STD ROTATION	1		4220453000		4220454000		4220455000				4220456000

PARTS LIST (Cont.)

CODE	DESCRIPTION	REQ	A	B	C	D	E	F	G	H	J	K
6950	MECH SEAL, FDA FLUORO CCW OR REVERSE ROTATION	1	4220457000			4220458000		4220459000			4220460000	
7100	TIE ROD NUT	8	4220424001			4220424002		4220424003			4220424004	
7200	KEY	1	6111010400			6111020700		6111040800			6111051000	
NOT SHOWN	STATOR REMOVAL PULL OUT SLEEVE 4230505-	1					001		002	003	004	

Double The Length Of Your Moyno Pump Warranty For FREE!

.....
For your *free* pump warranty extension, choose from one of the three options below:

1. Go to www.moyno.com and fill out the registration form online
2. Mail this form by placing it in an envelope and sending it to: **Moyno, Inc.**
Attn: Tish Wilson
P. O. Box 960
Springfield, OH 45501-0960
U.S.A.
3. Fax this form to 937-327-3177

Thank you for choosing a Moyno Pump. Please take the time to complete this warranty registration form. Upon receipt of your form, your standard limited warranty on defective material and workmanship will be extended to twice the standard period of time at no additional cost to you. We appreciate your business and look forward to serving you in the future.

Always Insist on Genuine Moyno Replacement Parts!

Moyno® Pump Warranty Registration

.....

Pump Model # _____ Pump Serial # _____
Purchased From _____ Date Purchased _____
Your Name _____ Your Title _____
Your Company Name _____
Address _____
City/State (Province)/Zip Code _____
Phone Number _____ Fax Number _____
E-mail _____

Application for Which This Pump Was Purchased

Material _____ Flow Rate _____ Process Temperature _____
Operating Speed _____ Viscosity _____ pH Value _____
Hours Operated per Day _____ Continuous _____ Intermittent _____
Discharge Pressure _____ Suction Pressure _____ NPSH Available _____
Percent of Solids _____ Particle Size _____ Abrasion Rating _____

How Did You First Hear of Moyno Pumps?

- Advertisement Postcard Trade Show Referral
 Distributor Salesperson Previous Experience With Moyno Pumps Other – Explain Below
-

Thank You!