

SPECIFICATION DATA
MOYNO® 500 PUMPS
400 SERIES GRINDER PUMPS
 415, 422, 433, AND 444 MODELS

DIMENSIONS

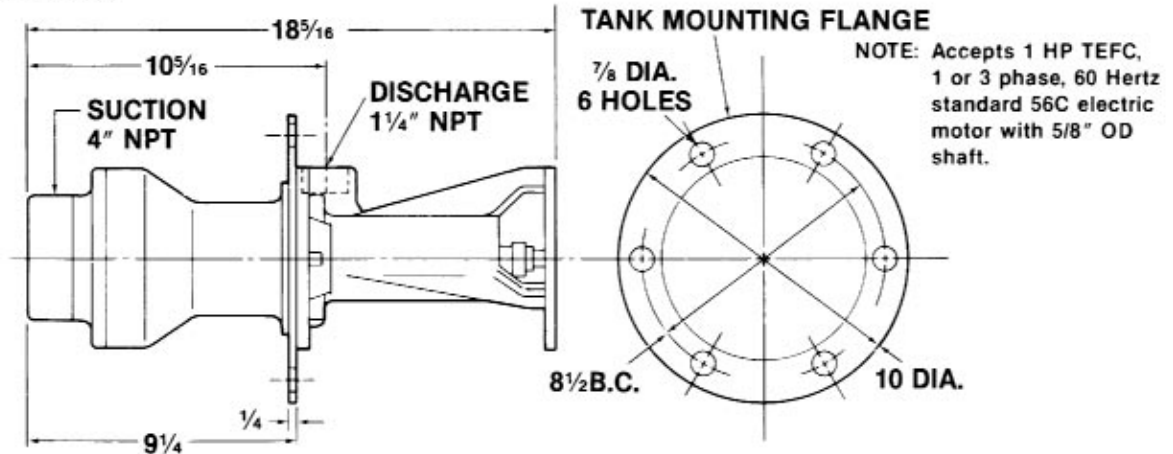

NOTE: Accepts 1 HP TEFC, 1 or 3 phase, 60 Hertz standard 56C electric motor with 5/8" OD shaft.
 All dimensions are in inches.
 Specifications subject to change without notice.

PERFORMANCE (1 HP, 1725 RPM, water at 70°F)

| HEAD IN FEET | DISCHARGE PRESSURE (PSIG) | CAPACITY IN GAL. PER MIN. BY MODEL NUMBER | | | |
|--------------|---------------------------|---|-------|-------|-------|
| | | 41502 | 42202 | 43302 | 44402 |
| 0 | 0 | 1.95 | 5.1 | 9.2 | 14.6 |
| 10 | 4.3 | 1.90 | 5.0 | 9.0 | 14.4 |
| 20 | 8.7 | 1.85 | 4.8 | 8.5 | 14.0 |
| 30 | 13.0 | 1.80 | 4.5 | 8.1 | 13.4 |
| 40 | 17.3 | 1.76 | 4.4 | 7.7 | 13.0 |
| 50 | 21.7 | 1.70 | 4.2 | 7.2 | 12.4 |
| 60 | 26.0 | 1.67 | 4.0 | 6.8 | 12.0 |
| 70 | 30.3 | 1.64 | 3.9 | 6.4 | 11.4 |
| 80 | 34.6 | 1.60 | 3.8 | 6.0 | 10.8 |
| NPSHR Ft. | | 1.2 | 1.9 | 2.6 | 4.1 |

NOTE: In application other than sewage, maximum fluid viscosity cannot exceed 100 CP (500 SSU).

MATERIALS OF CONSTRUCTION

Housing.....Cast iron
 Rotor.....416 Stainless steel
 Stator.....NBR (Nitrile)

WEIGHT:

Pump only.....50 lbs.
 Pump with motor.....90 lbs. (Approx.)

400 SERIES GRINDER PUMPS

