



Always the Right Solution™

Section:
MOYNO® 500 PUMPS

Page: 1 of 4

Date: March 2002

SERVICE MANUAL

MOYNO® 500 PUMPS

SANITARY/HYGIENIC NON-MOTORIZED

331, 332, 333 AND 344 MODELS

SANITARY MODELS

These pumps include housings polished to a #4 finish both inside and out. The mechanical seal is a 3A approved seal with carbon/ceramic faces. The elastomers meet the FDA requirement for food contact. These pumps meet 3A requirements. The universal joint may be dismantled for cleaning.

HYGIENIC MODELS

These pumps provide the quick disassembly features of the sanitary version for easy cleaning. The housings are 316 stainless steel construction, however, they are not polished. These pumps utilize rubber-covered universal joints. The stators are available in non-FDA nitrile, EPDM, and fluoroelastomers. The mechanical seals are rubber bellows type with carbon/ceramic faces.

INSTALLATION

Mounting Position. Pump may be mounted in any position. When mounting vertically, it is necessary to keep the bearings above the seals to prevent possible seal leakage into the bearings.

Pre-Wetting. Prior to connection the pump, wet the pump elements and mechanical seal by adding fluid to be pumped into suction and discharge ports. Turn the shaft over several times in a clockwise direction to work fluid into the elements.

Piping. Piping to the pump should be self-supporting to avoid excessive strain on pump housings.

Drive. On belt driven units, adjust belt tension to point of non-slip. Do not overtighten.

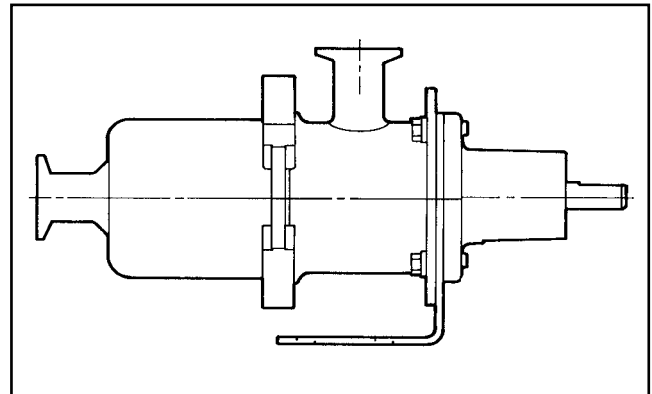

On direct drive units, coupling components should be aligned and spaced at least 1/16" apart.

Pump rotation must be clockwise when facing shaft to prevent damage to pump. Check direction of rotation before startup. Maximum speed is 1750 rpm.

Table 1. Pump Data

Pump Models	331	332	333	344
Discharge Pressure (psig) (maximum)	150	100	50	40

Table 2. Temperature Limits

Elastomer	Temperature Limits
*NBR (Nitrile)	10°-160°F
*EPDM	10°-210°F
FPM (Fluoroelastomer)	10°-240°F

* FDA Food Grade on Sanitary Models.

OPERATION

Self-Priming. With wetted pumping elements, the pump is capable of 25 feet of suction lift when operating at 1750 rpm with pipe size equal to port size.

DO NOT RUN DRY. The unit depends on liquid pumped for lubrication. For proper lubrication, the flow rate should be at least 10% of rated capacity.

Pressure and Temperature Limits. See Table 1 for maximum discharge pressure of each model. The unit is suitable for service at temperatures shown in Table 2.

Storage. Always drain the pump for extended storage periods by removing the suction housing and stator.

TROUBLESHOOTING

WARNING: Before making adjustments, disconnect power source and thoroughly bleed pressure from system prior to disassembly. Failure to do so could lead to electric shock or serious bodily harm.

Failure To Pump.

1. Belt or coupling slip: Adjust belt tension or tighten set screw on coupling.
2. Stator torn; possibly excessive pressure: Replace stator and check pressure at the discharge port.
3. Wrong rotation: Rotation must be clockwise when facing shaft.
4. Threads in rotor or on shaft stripped: Replace part. Check for proper rotation.
5. Excessive suction lift or vacuum.

Pump Overloads.

1. Excessive discharge pressure: Check discharge pressure for maximum rating given in Table 1. Check for obstruction in discharge pipe.
2. Fluid viscosity too high: Limit fluid viscosity to 20,000 CP or 100,000 SSU.
3. Insufficient motor HP: Check HP requirement, consult factory.

Viscosity CP	Limit RPM
1-300	1750
300-1,000	1200
1,000-2,000	700
2,000-5,000	350
5,000-10,000	180
10,000-20,000	100

Noisy Operation.

1. Starved suction: Check fluid supply, length of suction line, and obstructions in pipe.

2. Bearings worn: Replace parts; check alignment, belt tension, pressure at the discharge port.

3. Broken flexible joint: Replace part, check pressure at the discharge port.

4. Insufficient mounting: Mount to be secure to firm base. Vibration induced noise can be reduced by using mount pads.

Mechanical Seal Leakage.

1. Leakage at startup: If leakage is slight, allow pump to run several hours to let faces run in.
2. Persistent seal leakage: Faces may be cracked from freezing or thermal shock. Replace seal.

Pump Will Not Prime.

1. Air leak on suction side: Check pipe connections.

MAINTENANCE

General. These pumps have been designed for minimal maintenance — routine lubrication and adjustment of packing. The pump is one of the easiest to work on because the main elements are very accessible and require no tools to disassemble.

Bearing Lubrication. The prelubricated, fully sealed bearings do not require additional lubrication.

PUMP DISASSEMBLY

WARNING: Before disassembling pump, disconnect power source and thoroughly bleed pressure from system. Failure to do so could result in electrical shock or serious bodily harm.

1. Disconnect suction and discharge piping.
2. Remove quick clamp (80) holding suction housing (2) to pump body (1A). Remove suction housing and stator (21).
3. Remove rotor (22) from flexible joint (24) by turning counterclockwise (RH thread).
4. Flexible joints (24) can be removed from shaft (26) by turning counterclockwise with a 3/16 Allen wrench. Universal joints in the sanitary pump may be further disassembled by removing the snap rings, allowing the pins to be removed.
5. Carefully slide the mechanical seal (69) off the shaft (26). Carefully pry the seal seat out of the pump body (1A). If any parts of the mechanical seal are worn or broken, the complete seal assembly should be replaced. Seal components are matched parts and are not interchangeable.

6. The bearings (29) and shaft (26) assembly can be removed from pump body (1B) after the snap ring (66) has been removed. To remove the assembly, lightly tap the shaft at threaded end using a block of wood to protect the threads. The bearings may be pressed off the shaft.

PUMP ASSEMBLY

To Assemble Mechanical Models:

1. Press bearings (29) on the shaft (26), and locate the slinger ring (77) near the bearing on threaded end of shaft.

Note: When replacing bearings, always press on the inner race when assembling to shaft, and on the outer race when pressing bearings into the housings.

2. Press the shaft assembly into the pump body (1B) securing with snap ring (66).

3. Install the mechanical seal (69) using the following procedure:

a. Clean and lubricate sealing faces using a clean light vegetable oil (not grease).

Caution: Do not use oil on EPDM parts. Substitute glycerin or soap and water, or suitable food contact lubricant.

b. Lubricate the outer surface of the seal seat, and push the assembly into the bore in the pump body (1A), seating it firmly and squarely.

c. After cleaning and oiling the shaft, slide the seal body along the shaft until it meets the seal seat.

d. On Hygienic Models, install the seal spring and spring retainer on the shaft.

4. Thread the flexible joint (24) into the shaft (26) in a clockwise direction (RH thread). The sanitary joint must be pre-assembled using the drive pins, retained with the round snap rings. Thread the assembly (24) into the shaft (26) in a clockwise direction (RH thread) with gaskets (137 and 140) and seal driver (141) in place.

5. Thread the rotor (22) onto the flexible joint (24) in a clockwise direction (RH thread).

6. Slide the stator (21) on the rotor (22). On 331 and 332 Models, insert the rounded end of the stator ring (135) into end of the stator prior to installing the stator on the rotor.

7. Secure stator (21) and suction housing (2), with suction port vertically up, to pump body (1A) using quick clamp.

8. Proceed as in installation instructions.

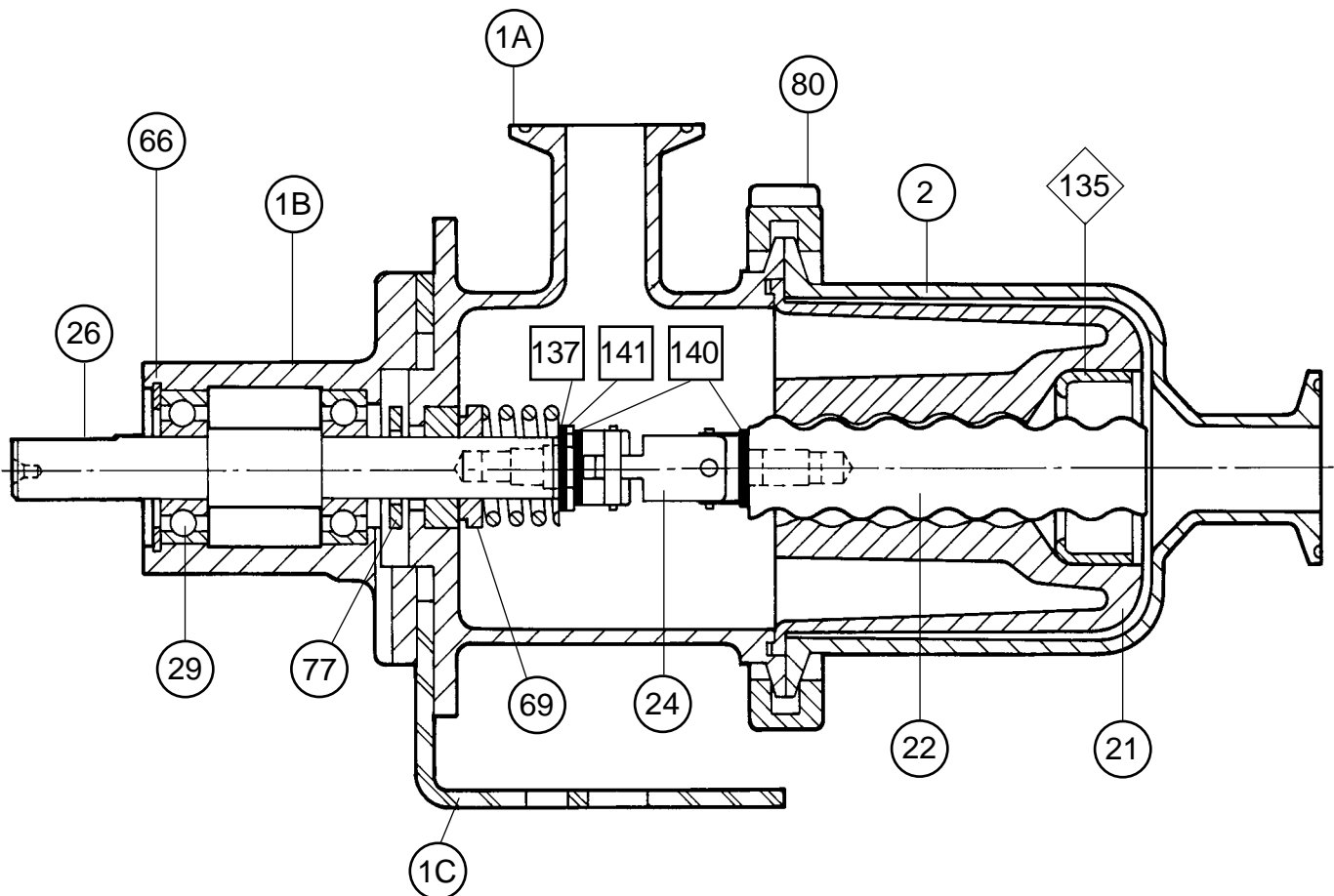

◇ - Use only on 331 & 332 Models.

□ - Use only on Sanitary Models.

PARTS LIST — 331, 332, 333 AND 344 MODELS

Item No.	Description	Sanitary	Hygienic
		33106 33206 33306 34406	33107 33207 33307 34407
1A	Discharge Housing	3403921007	3403922007
1B	Bearing Housing	3304587001	
1C	Pump Base	3402369002	3402369001
2	Suction Housing	3403919007	3403920007
*21	Stator	See Stator section below.	
*22	Rotor	See Rotor section below with numbers for each series. ① ②	
*24	Joint	3308810017	3208574001**
26	Drive Shaft	3308805000	
29	Bearing (2 req.)	6300502031	
66	Snap Ring	3201506000	
*69	Mechanical Seal	3208580000	3202424000
77	Slinger Ring	3206382000	
80	Clamp	3621775000	
135	Stator Ring (331 & 332 only)	3621774001	3207812000
137	Gasket .62 OD ***	3308806101	—
140	Gasket .78 OD ****	3308806102	—
141	Seal Driver	3308801015	—

Sanitary Joint Assy. Assy. No. 3308810017		
P/N	Description	Qty.
3207314015	Pin	2
3208575015	Snap Ring	2
3308802017	Joint End	2
3308803017	Joint Center	1

Not shown, required		
P/N	Description	Qty.
6191522160	Screw	4
6230012400	Lock Washer	4

ABRASION-RESISTANT SEALS
(Hygienic only)

Elastomer	All 331-344 Models
NBR	3206460000
EPDM	3206502000
FPM	3206503000

* Recommended spare parts. ** 001 Nitrile, 003 EPDM, 005 FPM
 *** 101 Nitrile, 301 EPDM, 501 FPM
 **** 102 Nitrile, 302 EPDM, 502 FPM

Sanitary Models					
Stators-Sanitary		331	332	333	344
21	Standard Stator, FDA Nitrile	3403501110	3403502110	3403503110	3403504110
21	EPDM Stator, † FDA EPDM	3403501300	3403502300	3403503300	3403504300
21	FPM Stator (Not Food Grade)	3403501520	3403502520	3403503520	3403504520
Hygienic Models					
Stators-Hygienic		331	332	333	344
21	Standard Stator, NBR All Models	3403501120	3403502120	3403503120	3403504120
21	EPDM Stator	3403501320	3403502320	3403503320	3403504320
21	FPM Stator	3403501520	3403502520	3403503520	3403504520
Rotors					
22	① 316 SS-All Models (Sanitary)	3208576000	3208577000	3208578000	3208579000
22	② 316 SS-All Models (Hygienic)	3202933000	3202942000	3202936000	3202934000

† EPDM does not meet 3A or dairy requirements.

When ordering parts, please specify pump model number, pump serial number, part number, part description and quantity.

For additional information on pumps, call 1-800-845-1310; on parts, call 1-800-325-1331. In Ohio, for information on either pumps or parts, call 937-327-3553.

Double The Length Of Your Moyno Pump Warranty For FREE!

For your *free* pump warranty extension, choose from one of the three options below:

1. Go to www.moyno.com and fill out the registration form online
2. Mail this form by placing it in an envelope and sending it to: **Moyno, Inc.**
Attn: Tish Wilson
P. O. Box 960
Springfield, OH 45501-0960
U.S.A.
3. Fax this form to 937-327-3177

Thank you for choosing a Moyno Pump. Please take the time to complete this warranty registration form. Upon receipt of your form, your standard limited warranty on defective material and workmanship will be extended to twice the standard period of time at no additional cost to you. We appreciate your business and look forward to serving you in the future.



Always Insist on Genuine Moyno Replacement Parts!

Moyno® Pump Warranty Registration

Pump Model # _____ Pump Serial # _____
 Purchased From _____ Date Purchased _____
 Your Name _____ Your Title _____
 Your Company Name _____
 Address _____
 City/State (Province)/Zip Code _____
 Phone Number _____ Fax Number _____
 E-mail _____

Application for Which This Pump Was Purchased

Material _____ Flow Rate _____ Process Temperature _____
 Operating Speed _____ Viscosity _____ pH Value _____
 Hours Operated per Day _____ Continuous _____ Intermittent _____
 Discharge Pressure _____ Suction Pressure _____ NPSH Available _____
 Percent of Solids _____ Particle Size _____ Abrasion Rating _____

How Did You First Hear of Moyno Pumps?

- Advertisement
 Postcard
 Trade Show
 Referral
 Distributor Salesperson
 Previous Experience With Moyno Pumps
 Other – Explain Below

Thank You!