

LAWN SPRINKLER PUMPS

SELF PRIMING SPRINKLER PUMPS



SPHE SERIES SPRINKLER PUMP

Ideal for both residential and commercial lawn and turf sprinkler systems.

CASING AND SEAL PLATE – Built from rugged cast iron.

SHAFT SEAL – Standard 5/8" rotating mechanical seal, for a reliable seal against water leakage.

IMPELLER – Precision molded glass filled thermoplastic is extra smooth, for highest pump efficiency and longevity.

REPLACEABLE DIFFUSER – Glass filled engineered thermoplastic, can be serviced easily and inexpensively to maintain high pump efficiency.

SUCTION – 2" NPT Suction.

DISCHARGE – 1½" NPT Discharge.

DRAIN PLUG – For easy drainage of pump.

PRIMING PLUG – To facilitate rapid priming.

O-RING CASING SEAL – For positive seal and ease of service.

BRASS WEAR RING – Installed in diffuser to maximize hydraulic pump efficiency.

MOTOR – Single phase capacitor start, 115/230 volt with **higher than NEMA service factors**. Stainless Steel motor shaft for corrosion resistance.

Performance

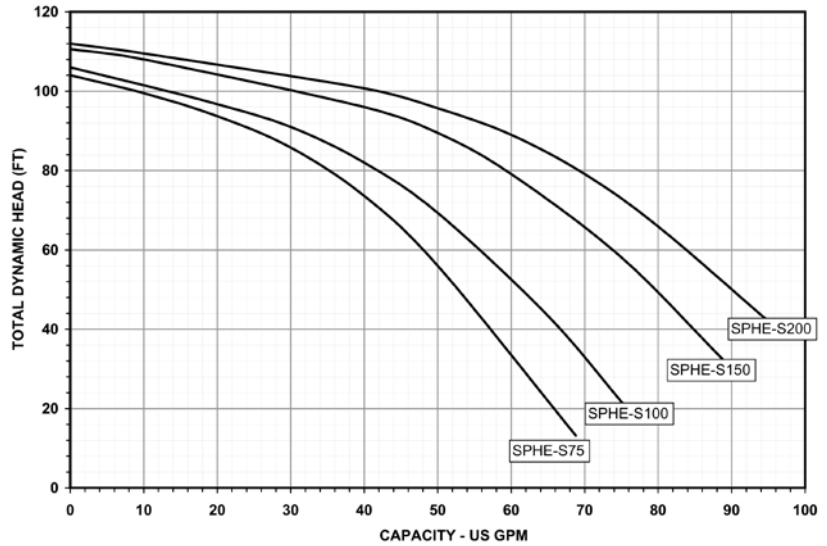

Model No.	HP	Discharge Pressure in PSI at 5 ft. Lift				Max. PSI
		10	20	30	40	
SPHE-S75	¾	63	52	40	12	45
SPHE-S100	1	72	62	46	20	46
SPHE-S150	1½	90	80	64	40	47
SPHE-S200	2	97	90	74	47	48

Dimensions

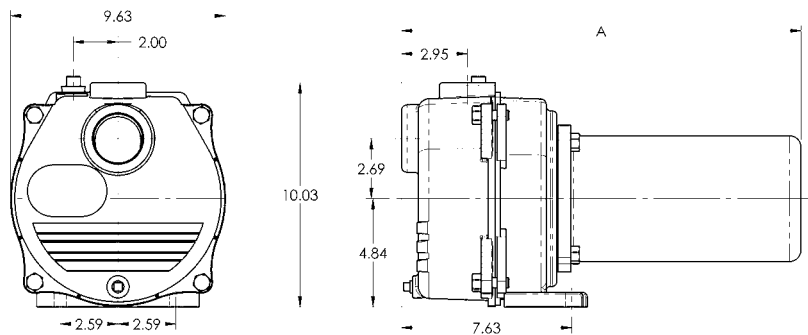

"A" Dimensions	
SPHE-S75	10.88"
SPHE-S100	11.88"
SPHE-S150	12.63
SPHE-S200	12.65

*Dimensions measured in inches

SPHE SELF PRIMING CENTRIFUGAL PUMP							Description
Model No.	Order No.	HP	SF	Suct. NPT	Disch. NPT	Ship Wt. (lbs.)	
SPHE-S75	614661	¾	1.65	2"	1½"	64	All SPHE motors are single phase capacitor start, 115/230 volt with higher than NEMA standard service factors. Stainless steel motor shaft for corrosion resistance.
SPHE-S100	614662	1	1.65	2"	1½"	66	
SPHE-S150	614663	1½	1.47	2"	1½"	72	
SPHE-S200	614664	2	1.30	2"	1½"	76	