

WATER SYSTEMS

SHALLOW WELL JET PUMPS

MJS SERIES

SHALLOW WELL JET PUMPS

Pump - motor assembly with internal injector and 30-50 PSI pressure switch and pressure gauge. All pumps have 1 1/4" NPT suction and 1" NPT discharge. Model MJSHP-50 is recommended for 40-60 PSI pressure setting.

Ideal for supplying pressurized freshwater to rural homes, farms and cabins. For use where the vertical distance from the water supply does not exceed 25 feet.

- Cast Iron casing and seal plate ensures durability and long life.
- Precision engineered thermoplastic impeller, diffuser, nozzle and venturi.
- A.O. Smith **higher than standard Nema service factor** dual compartment motors.
- Dual voltage (115/230) Stainless Steel Motor Shaft, Dual Ball Bearing.
- Square D pressure switch preset at 30-50 PSI for today's modern living conditions.
- John Crane type 6 mechanical seal ensures years of leak free operation.
- Fully serviceable with two year over the counter warranty.
- Clean out plug to easily unclog nozzle.
- Pressure gauge included on all models.



Dual compartment A.O. Smith motor



MJS-50

Dimensions

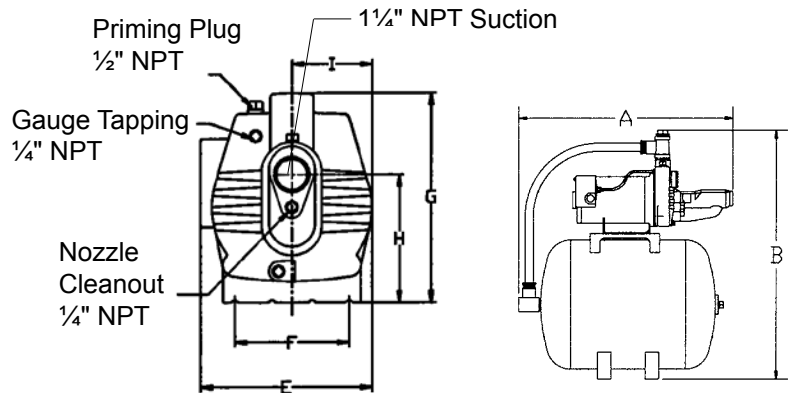
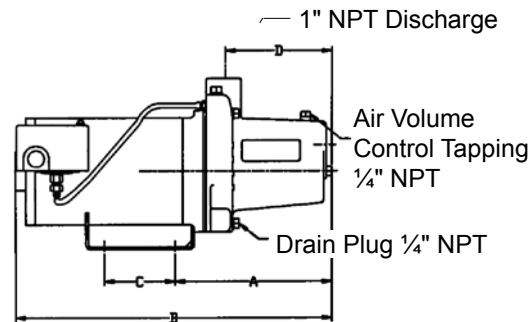

Model	Suct.	Disch.	A	B	C	D	E	F	G	H	I	Ship Wt. (lbs)
MJS-50	1 1/4"	1" NPT	9.38	17.3	3	6	9	4.85	9.8	4.62	3.5	36
MJS-75	1 1/4"	1" NPT	9.38	17.3	3	6	9	4.85	9.8	4.62	3.5	37
MJS-100	1 1/4"	1" NPT	9.38	17.3	3	6	9	4.85	9.8	4.62	3.5	38
MJSHP-50	1 1/4"	1" NPT	9.38	17.3	3	6	9	4.85	9.8	4.62	3.5	36

*Dimensions measured in inches

Model	HP	Tank (Gal.)	Length	Width	Height	Ship Wt. (lbs)
MJS-50/PC25S	1/2	8.5	25"	13"	29"	57



MJS

Water Systems

Sump and Sewage

Lawn and Sprinkler

Electric Motor Driven

Engine Driven

Frame Mount

Hand Pumps

Irrigation and Industrial

WATER SYSTEMS

SHALLOW WELL JET PUMPS

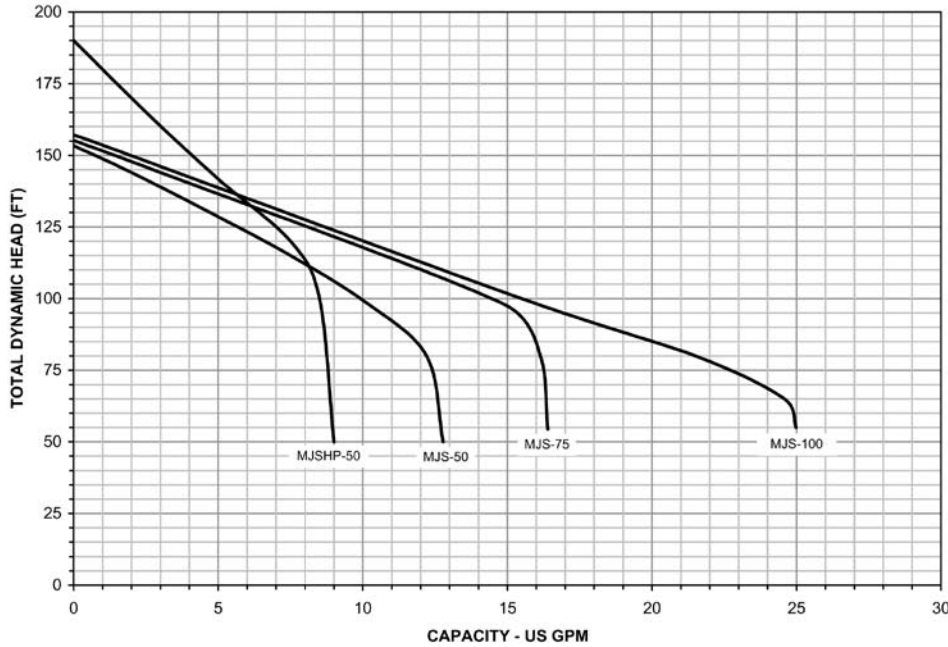

MJS-50/PC25S

PERFORMANCE TABLE

Pump Model	Motor HP	Total Suction Lift (ft.)	Pump Capacity in U.S. GPM													Maximum Pressure
			Discharge Pressure in PSI													
			20	25	30	35	40	45	50	55	60	65	70	75	80	
MJS-50	½	5	12.8	12.5	12.3	12.1	11.2	9.5	6.9	4.3	2.0	-	-	-	-	64.2
		10	11.5	11.3	11.0	10.8	10.4	8.5	6.0	3.4	1.0	-	-	-	-	62.0
		15	9.8	9.7	9.6	9.5	9.4	7.3	4.7	2.2	-	-	-	-	-	59.9
		20	8.3	8.1	7.8	7.7	7.6	5.7	3.5	1.0	-	-	-	-	-	57.7
		25	5.6	5.55	5.5	5.4	5.3	4.1	2.3	0.2	-	-	-	-	-	55.5
MJS-75	¾	5	16.2	16.0	15.8	15.6	15.4	12.1	8.7	5.7	2.9	-	-	-	-	65.0
		10	14.3	14.0	13.7	13.5	13.2	10.6	7.6	4.6	1.6	-	-	-	-	62.8
		15	12.1	11.7	11.3	11.0	10.6	9.3	6.3	3.2	0.2	-	-	-	-	60.6
		20	9.9	9.6	9.3	9.0	8.7	7.8	4.8	1.9	-	-	-	-	-	58.5
		25	7.2	7.1	7.0	6.9	6.8	6.7	3.5	0.6	-	-	-	-	-	56.3
MJS-100	1	5	24.8	24.7	23.2	19.8	16.5	13.1	9.5	6.3	3.4	0.5	-	-	-	66.2
		10	21.5	21.2	20.1	18.4	15.2	11.5	7.9	4.9	2.4	-	-	-	-	64.2
		15	18.1	17.8	17.4	16.7	13.8	10.3	6.9	4.0	1.3	-	-	-	-	62.1
		20	14.4	14.3	14.2	14.6	12.3	9.0	5.3	2.3	0.2	-	-	-	-	60.1
		25	10.5	10.5	10.4	10.3	8.8	7.0	4.2	1.3	-	-	-	-	-	57.2
MJS HP-50 High Pressure	½	5	8.8	8.9	8.6	8.4	8.3	8.1	7.4	6.0	4.7	3.4	2.2	1.2	0.15	80.6
		10	7.8	7.7	7.55	7.4	7.25	7.2	6.6	5.4	4.15	2.8	1.8	0.7	-	78.5
		15	6.5	6.4	6.3	6.2	6.1	6.0	5.3	4.8	3.6	2.3	1.3	0.3	-	76.3
		20	5.3	5.2	5.1	4.9	4.8	4.7	4.6	4.1	2.9	1.7	0.7	-	-	74.1
		25	3.7	3.65	3.6	3.55	3.5	3.5	3.45	2.4	2.3	1.3	0.3	-	-	71.9

MJS SERIES - FOR SHALLOW WELLS TO 25 FEET

Model	Order #	HP	SF	Amps	Voltage	Ship Wt. (lbs.)	Description
MJS-50	602002	½	1.90	9.0/4.5	115/230	36	½ HP Shallow well jet pump, with gauge
MJS-75	602003	¾	1.65	14.8/7.4	115/230	37	¾ HP Shallow well jet pump, with gauge
MJS-100	602004	1	1.65	19.2/9.6	115/230	39	1 HP Shallow well jet pump, with gauge
MJSHP-50	602011	½	1.90	9.0/4.5	115/230	36	½ HP High Pressure Shallow well jet, with gauge

SHALLOW WELL JET PUMP AND TANK PACKAGED SYSTEMS

MJS-50/PC25S	602013	½	1.90	9.0/4.5	115/230	64	Jet pump with 8.5 gallon Flexcon tank, with gauge
--------------	--------	---	------	---------	---------	----	---

MJS

Water Systems

Sump and Sewage

Lawn and Sprinkler

Electric Motor Driven

Engine Driven

Frame Mount

Hand Pumps

Irrigation and Industrial