

# WATER SYSTEMS CONVERTIBLE JET PUMPS

MJC

Water Systems

Sump and Sewage

Lawn and Sprinkler

Electric Motor Driven

Engine Driven

Frame Mount

Hand Pumps

Irrigation and Industrial

## MJC SERIES CONVERTIBLE JET PUMPS

Pump - motor assembly with deep well injector and extra venturi. All pumps have 30-50 PSI pressure switch, pressure gauge, 1 1/4" suction, 1" discharge, and brass flow control valve.

Ideal for supplying pressurized freshwater to rural homes, farms and cabins. For use where the vertical distance from the water supply does not exceed 90 feet. The injector can be attached to the pump casing for shallow well performance.

- Cast Iron casing and seal plate ensures durability and long life.
- Precision engineered thermoplastic impeller, diffuser, nozzle and venturi.
- A.O. Smith **higher than standard Nema service factor** dual compartment motors.
- Dual voltage (115/230) Stainless Steel Motor Shaft, Dual Ball Bearing.
- Square D pressure switch preset at 30-50 PSI for today's modern living conditions.
- John Crane type 6 mechanical seal ensures years of leak free operation.
- Fully serviceable with two year over the counter warranty.
- Pressure gauge included on all models.
- Deep well venturi supplied loose in carton on all models



Dual compartment A.O. Smith motor



MJC-50

### Dimensions

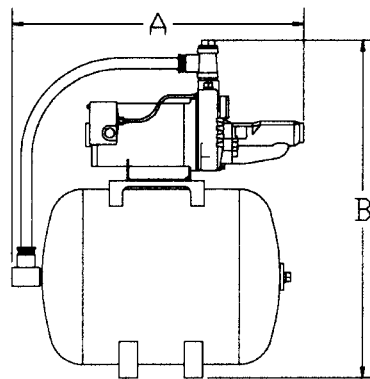
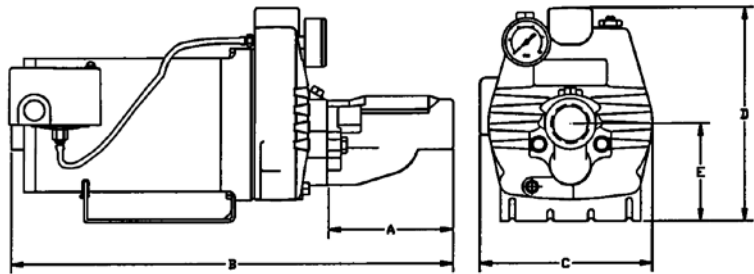

Model	Suct.	Disch.	A	B	C	D	E	Ship Wt. (lbs)
MJC-50	1 1/4"	1" NPT	5.38	18.78	9.0	10.0	4.3	36
MJC-75	1 1/4"	1" NPT	5.38	19.58	9.0	10.0	4.3	37
MJC-100	1 1/4"	1" NPT	5.38	20.58	9.0	10.0	4.3	38

\*Dimensions measured in inches

Model	HP	Tank (Gal.)	Length	Width	Height	Ship Wt. (lbs)
MJC-50/PC25S	1/2	8.5	25"	13"	29"	57

# WATER SYSTEMS

## CONVERTIBLE WELL JET PUMPS



MJC-50/PC25S

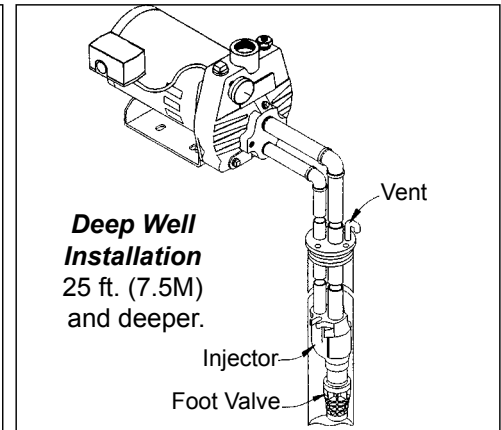
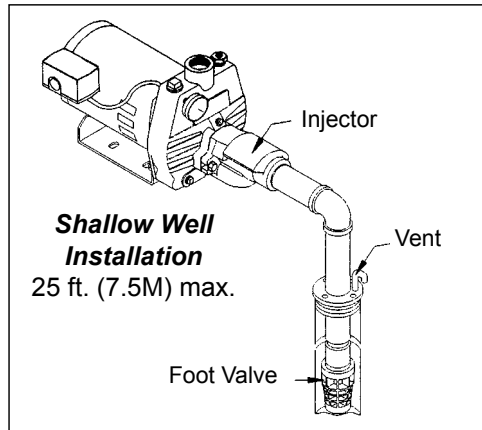

**Shallow:** Single pipe shallow well installation.  
**Deep:** Double pipe deep well installation.

PERFORMANCE TABLE													
Pump Model	Motor HP	Configuration	Total Suction Lift (ft.)	Pump Capacity in U.S. GPM									Maximum Pressure
				Discharge Pressure in PSI									
				20	25	30	35	40	45	50	55	60	
MJC-50	1/2	Shallow	5	11.1	11.0	10.9	10.8	10.7	9.2	7.4	5.9	4.5	76.2
			15	8.1	8.0	7.9	7.8	7.7	7.3	5.9	4.4	3.1	71.7
			25	4.8	4.8	4.7	4.7	4.6	4.5	4.4	3.2	1.9	67.5
		Deep	20	-	10.7	9.2	7.8	6.5	5.4	4.5	3.6	2.9	85.0
			50	-	6.8	5.8	4.8	4.0	3.2	2.4	1.8	1.3	72.0
			80	-	4.1	3.4	2.8	2.2	1.6	1.0	0.4	-	59.0
MJC-75	3/4	Shallow	5	18.2	17.9	17.7	16.6	14.3	12.0	9.7	7.4	5.1	71.0
			15	12.7	12.5	12.4	12.2	12.0	9.9	7.5	5.3	3.0	66.7
			25	7.7	7.5	7.4	7.1	6.9	6.7	5.0	3.0	1.0	62.4
		Deep	20	-	11.5	9.8	7.6	6.8	5.7	4.7	3.8	3.0	86.0
			50	-	7.4	6.1	5.1	4.1	3.3	2.5	1.9	1.3	73.0
			90	-	4.5	3.5	2.8	2.1	1.5	1.0	0.5	-	60.0
MJC-100	1	Shallow	5	20.2	20.1	19.9	19.5	16.7	13.9	11.1	8.3	5.6	71.0
			15	14.5	14.3	14.1	13.8	13.6	11.4	8.7	6.0	3.3	66.7
			25	9.1	8.9	8.8	8.7	8.6	8.5	6.0	3.6	1.2	62.1
		Deep	20	-	12.8	10.5	8.7	7.3	6.6	5.2	4.4	3.6	87.0
			50	-	8.4	7.2	6.0	5.0	4.2	3.4	2.6	1.9	74.0
			90	-	4.3	3.4	2.7	1.9	1.8	0.7	-	-	56.7

MJC SERIES - FOR WELLS TO 90 FEET							
Model	Order #	HP	SF	Amps	Voltage	Ship Wt. (lbs.)	Description
MJC-50	602032	1/2	1.90	9.0/4.5	115/230	36	Pump - motor assembly with deep well injector, includes gauge.
MJC-75	602033	3/4	1.65	14.8/7.4	115/230	37	
MJC-100	602034	1	1.65	19.2/9.6	115/230	39	
SHALLOW WELL JET PUMP AND TANK PACKAGED SYSTEMS							
MJC-50/PC25S	602058	1/2	1.65	9.0/4.5	115/230	64	Jet pump with 8.5 gallon Flexcon tank, includes gauge.

MJC

Water Systems

Sump and Sewage

Lawn and Sprinkler

Electric Motor Driven

Engine Driven

Frame Mount

Hand Pumps

Irrigation and Industrial