

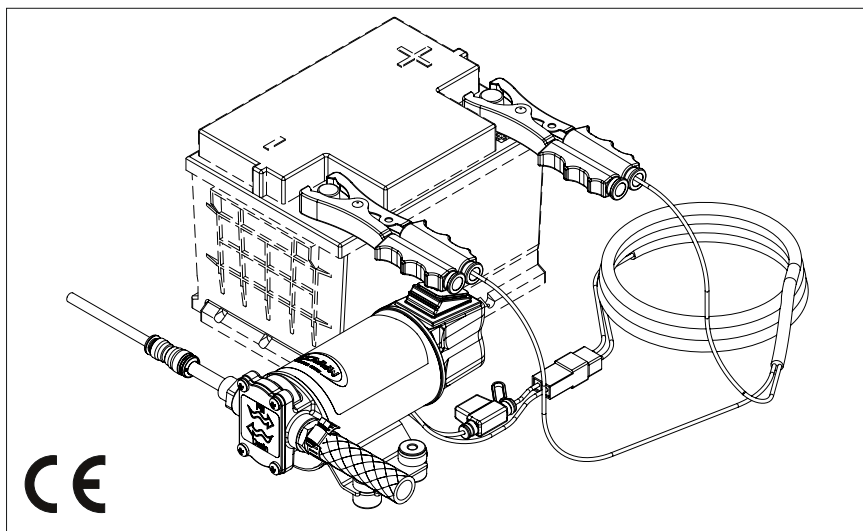

**ELETTROPOMPA AUTOADESCANTE
PER TRAVASO LIQUIDI
SELF-PRIMING ELECTRIC PUMP
FOR TRANSFERRING VARIOUS LIQUIDS**

**AVVERTENZE D'USO
INSTRUCTIONS FOR USE**

**164 932 12 - OCK1-R 12V
164 932 13 - OCK1-R 24V**



PRODUCT DESCRIPTION

Self-priming electric pump designed for lubricants and viscous fluids (see chapter exclusions) for discontinuous or intermittent usage. The pumping elements are made up of bronze gear drives which can possibly even run dry for brief periods. Completely equipped with fast connector for oil suction pipe.

TECHNICAL DETAILS



Tab.1 EN		CODE	TYPE	VOLT	FUSE	FLOW RATE (25°C SAE-30 OIL)						WEIGHT		WIRE SIZE **	
														kg	lb
164 932 12	OCK1-R	12	A	10	l/h	Ø6	20	Ø8	60	Ø13	330	3,1	mmq	1,5	
164 932 13		24		5	gph	5	16	87	AWG		14				
** Length up to 4 m IP67 Protection															

APPLICATIONS

There are numerous fields of applications for the pump, however only exclusively with the allowed liquids mentioned:

- transfer of oils;
- transfer of viscous liquid;
- transfer of light weight lube oils, antifreeze, etc...
- draining of engine sumps;

FLUIDS ALLOWED / NOT ALLOWED [®]

Tab.2 EN		<u>LIQUIDS</u>		<u>DANGERS</u> 					
		WARRANTY EXPIRES IF MAX FLUID TEMPERATURE IS EXCEEDED		FIRE / EXPLOSION	MOTOR OVERHEATING	FOODSTUFF LIQUID CONTAMINATION	PUMP CORROSION	INJURY TO PERSONNEL	DAMAGE TO SEALS
OK	FRESH WATER (max 85°C-185°F)								
	DIESEL FUEL*								
	OIL								
NO 	PETROL (GASOLINE)			●					
	FLAMMABLE LIQUIDS with PM < 55°C-131°F			●					
	LIQUIDS WITH VISCOSITY > 350 cSt				●				
	FOODSTUFF LIQUIDS					●			
	CORROSIVE CHEMICAL PRODUCTS							●	●
	SOLVENTS			●					●
* Minimum flashpoint (PM): 55°C-131°F.									
ISO 8846 Compliant Device									

AMBIENT CONDITIONS

TEMPERATURE: min.-10°C 14°F-max.60°C 140°F **RELATIVE HUMIDITY:** max. 90 %

 **WARNING:** the above indicated temperature ranges are applicable to all components of the pump and these limits must be respected in order to avoid any possible damage or malfunctioning.

OPERATING CYCLE

The pump has been designed for discontinuous use. Under conditions of high operating pressures (eg. with closed or blocked outlet, excessive length of the delivery circuit and/or excessive pressure due to accessories), it can be subjected to elevated stresses and overheating and therefore should not be used for prolonged periods under such conditions.

TRANSPORTATION AND HANDLING

Due to limited weight and dimensions the pump does not require the use of any special handling or lifting equipment. When handling manually, normal personal protective gear should be worn (safety shoes with toe piece, etc.). The pump is carefully packed prior to shipment. Upon receiving, the packaging should be inspected for damages and the pump stored in a dry area.

INSTALLATION

It is recommended that the use of the pump be according to normative safety standards and also as per the precautions listed below.

PRELIMINARY CHECKS

Check that there has been no damage to the pump during transportation or storage. Both inlet and outlet ports should be carefully cleaned removing possible dust or residual packaging material. Verify that the available electrical power supply corresponds to the specification requirements.

POSITIONING

The pump can be mounted in any position. Fix it utilizing suitable screws corresponding to the antivibration mounts supplied.

To ensure the correct directional flow of the fluid as indicated by the arrow on the top plate, it is necessary to connect the positive pole (+) of the battery supply to the red wire on the motor end-cap and the negative pole (-) to the black wire. Electrical connections must be made using adequate terminal blocks and connectors ensuring a tight fitment of the electrical cables. Bad wiring can cause power losses and/or overheating of the cabling itself.

 **WARNING:** it is the responsibility of the installation technician to ensure a correctly designed circuit installation fitted according to regulations. Environmental risks must be taken into account with the installation.

TUBING CONNECTIONS

- Prior to making any tube/hose connections, check that the inlet ports have no end caps;
- Do not position the pump at a excessive height with respect to the minimum level of the fluid to be transferred. Damage may occur if this height is exceeded as the pump may not draw fluid. Make sure that the outlet tube is empty and without chokes;
- Avoid choking the inlet or outlet tubes so that efficiency is optimized.
- The use of an inlet filter is recommended especially with fluids containing impurities (ASTM mesh 35). In this case frequent cleaning and maintenance of the filter is advisable. The standard filter withstands a maximum positive pressure of 0.5 bar.
- Utilize tubes and connection pieces that are resistant to the fluid types handled and avoid any possible environmental dispersion.

ELECTRICAL CONNECTION

The electrical installation of the pump must include a protection fuse which is suitably rated as indicated on the motor label.

WARRANTY EXPIRES IF NO FUSE IS UTILIZED

Always mount the anti vibration rubber fittings supplied with the pump kit. Their usage ensures a consistent reduction in noise and vibration levels. Electrical cabling size should depend on the distance between pump and battery power supply (see Tab.1 EN). The use of undersized cabling can cause overheating of the electrical wiring and subsequent fire hazard. There will also be a voltage drop at the motor terminals with a consequent reduction in efficiency. The flow rate value indicated on the motor label is obtained with internal tube diameter indicated on Tab.1 EN. Tubes with inferior diameters will cause an increase in current with potential risk of motor overheating.

TROUBLESHOOTING

CHECK POINTS IF THE PUMP HAS STOPPED OR WILL NOT START

- Check the effectiveness of the battery power supply (voltage activity);
- Check if the fuse has blown;
- Check for any foreign matter present in the pump body. To do this, disconnect the power supply and unscrew the four fixing screws, remove the front cover plate and inspect the chamber. Replace the cover plate in the same initial position after inspection;
- Avoid running the pump dry for more than a few minutes. Pumps found defective that have run dry in the absence of fluid are not covered by warranty;
- The average life span of the motor commutator brushes is approximately 1500 hours under normal operating conditions. Stoppages are possible due to brush wear and tear after such a time period.

WHY THE PUMP WILL NOT PRIME ITSELF?

- The pump is fitted at an excessive height above the fluid level;
- The pump has run dry for too long a period;
- Long periods of inactivity. In this case it is advisable to add liquid directly into the chamber before start-up. It is also advisable to add, before running the pump, a drop of lubricating oil inside the pump only;
- Air leak at the suction pipe due to the following reasons, possible cuts in the pipe, inadequate hose clamps, malfunctioning of the filter due to defective/worn seals or filter clogged;
- Air leak at the front plate cover due to the following reasons, loose fixing screws, poor effectiveness of the seal;
- Faulty electrical cable connections;
- Presence of obstructions or restrictions in the suction or delivery pipes or the use of special devices(eg. automatic spray pistol or aqua-stop);
- Presence of liquid loops in the outlet tube.

GOOD PRACTICES ENSURING A WELL FUNCTIONING PUMP

If it is expected that the pump will not be used for a period of at least 30 days, especially in the case of usage with water, it is advisable to run fresh water through it and to then loosen the front plate screws. Upon re-use, run the pump briefly (a few seconds) and tighten the screws again. Check under conditions of maximum operating pressure that the motor current value is within the motor label specifications.

NORMAL MAINTENANCE

- Check frequently and keep the inlet filter clean;
- Check every month the chamber and keep clean from any foreign matter;
- Check every month that electrical wiring is in good condition;
- Every 1500 hours of pump operation substitute the motor brushes.
- Replace the rubber impeller every season or every 500 hours (for UP1-J-N-M)

INDICATORS THAT THE PUMP IS FUNCTIONING CORRECTLY

- Temperature of body and motor frame is within 60°C - 70°C (140°F - 158°F);
- Regular flow and constant noise levels;
- Amp-draw within the limits indicated in the technical details.

TO OPEN THE PUMP

- It is recommended that a specialized service technician be consulted for any repair work or the replacement of worn out internal components, exclusively with original spare parts;
- During the warranty period, only by authorized Marco S.p.A. personnel, failing which the warranty will expire.

ENVIRONMENTAL DISPOSAL

Do not dispose of pumps into household waste: pumps that are no longer usable, must be collected separately and disposed of in an environmentally correct manner. ⑧

PACKAGING ENVIRONMENTAL DISPOSAL

The user is invited to effect a proper waste separation, in order to facilitate the recycling of the materials of which the packing is composed.

WARRANTY

- 1) The Warranty period is 2 years from date of purchase on production of the appropriate sales invoice.
- 2) Should the original sales invoice not be available, then the 2 year warranty period will be valid from production date.
- 3) The Warranty becomes null and void in the case of incorrect utilization or disregard of the instructions contained herein.
- 4) The Warranty only covers original production defects.
- 5) The Warranty does not cover any related installation costs involved.
- 6) Transport costs are refundable only in the case where warranty has been duly accepted by Marco Spa and they will be limited to the actual shipment costs between Marco Spa warehouse and the client's delivery address.
- 7) No credit notes or replacement items will be issued prior to the receipt and proper testing of any Marco goods that are deemed faulty.

SEQUENZA DI MONTAGGIO / MOUNTING SEQUENCE

1. Montare gli antivibranti (2) sulla pompa (1);
 2. Avvitare il portagomma (4), completo di o-ring (3), sul corpo pompa (1);
 3. Infilare la fascetta stringi tubo (5) sul tubo retinato (6);
 4. Calzare il tubo retinato (6) sul portagomma (4) ed avvitare la fascetta stringitubo (5);
 5. Avvitare l'innesto rapido (7) sul corpo pompa (1);
 6. Nel caso si voglia utilizzare il tubo Rilsan \varnothing 8/6 L=1.2 m (8) come aspirazione, infilarlo nell'innesto rapido (7) fino a sentire uno scatto: per accertarsi della corretta installazione verificare che tirandolo non si sfili dall'innesto rapido (7);
 7. Nel caso si voglia utilizzare il tubo Rilsan \varnothing 6/4 L=1.2 m (11) come aspirazione, infilare il tubo Rilsan 8/6 L=0,3 m (9) nell'innesto rapido (7) fino a sentire uno scatto. Per accertarsi della corretta installazione verificare che tirandolo non si sfili. Ripetere la stessa operazione infilando l'altra estremità del tubo Rilsan (9) nel giunto (10). Con le stesse modalità infilare il tubo Rilsan (11) nel giunto (10) e verificarne il corretto montaggio;
 8. Per estrarre i tubi Rilsan (8) (9) (11) dall'innesto rapido (7) o dal giunto (10), premere la ghiera in plastica nera contro la parte in metallo, nella direzione opposta a quella di estrazione del tubo;
-
1. Mount the isolators (2) on the pump (1);
 2. Screw the hose fitting (4) complete with OR (3), on the pump (1);
 3. Fit the hose clamp (5) on the hose (6);
 4. Connect the hose (6) on the hose fitting (4) and screw the hose clamp (5);
 5. Screw the quick fitting (7) on the pump body (1);
 6. As an option, the Rilsan hose \varnothing 8/6 L=1.2 m (8) can be connected on the inlet side: for its proper connection, press the hose in the quick fit (7) and check by pulling for sufficient force;
 7. As an option, the hose \varnothing 8/6 L=0.3 m (9) can be connected on the inlet side: the quick coupling (10) must be used to join the Rilsan hose (9) with Rilsan hose \varnothing 6/4 L=1.2 m (11). Check by pulling for sufficient retention force;
 8. To pull out the Rilsan hose (8), (9), (11) from quick fit (7) or coupling (10), press the black chape and pull the hose all at once;

SCHEDA DI ASSEMBLAGGIO / EXPLODED VIEW

Pos.	Q.tà	Descrizione
1	1	POMPA
2	4	ANTIVIBRANTI
3	1	O-RING
4	1	PORTAGOMMA
5	1	FASCETTA
6	1	TUBO RETINATO

Pos.	Q.tà	Descrizione
7	1	INNESTO RAPIDO
8	1	TUBO RILSAN Ø 8/6 L=1,2 m
9	1	TUBO RILSAN Ø 8/6 L=0,3 m
10	1	GIUNTO
11	1	TUBO RILSAN Ø 6/4 L=1,2 m
12	1	CAVO CON PINZE

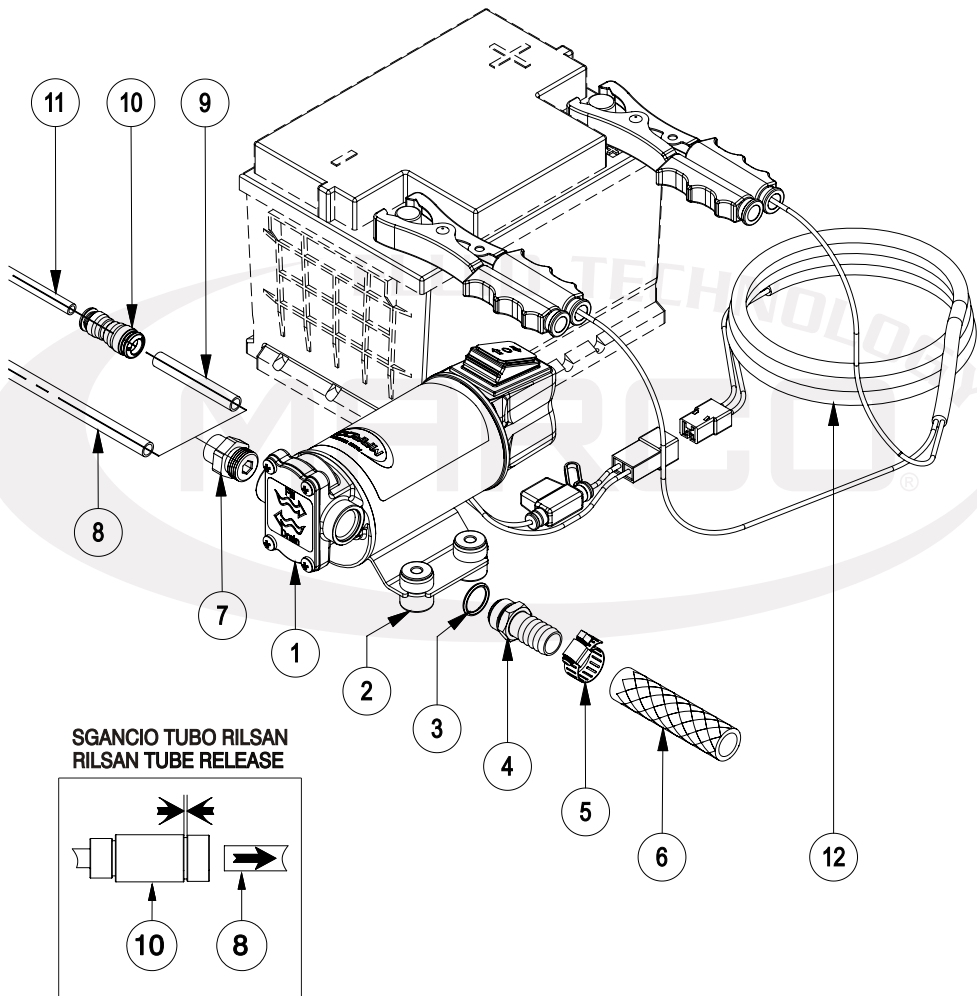

SGANCIO TUBO RILSAN
RILSAN TUBE RELEASE

Pos.	Q.ty	Description
1	1	PUMP
2	4	ANTIVIBRATION MOUNT
3	1	O-RING
4	1	TUBE OUTLET
5	1	HOSE CLAMP
6	1	TUBE

Pos.	Q.ty	Description
7	1	QUICK FIT
8	1	RILSAN TUBE Ø 8/6 L=1,2 m
9	1	RILSAN TUBE Ø 8/6 L=0,3 m
10	1	COUPLING
11	1	RILSAN TUBE Ø 6/4 L=1,2 m
12	1	CABLE WITH CROCODILE CLIP

SCHEDA DI ASSEMBLAGGIO / EXPLODED VIEW

Pos.	Q.tà	Descrizione
1	1	CORPO POMPA
2	2	TIRANTE
3	1	CARCASSA
4	1	INDOTTO
5	1	O-RING
6	1	CALOTTA
7	2	O-RING
8	2	RONDELLA
9	2	DADO

Pos.	Q.tà	Descrizione
10	1	FUSIBILE
11	1	INGRANAGGIO FOLLE
12	1	LINGUETTA
13	1	INGRANAGGIO TRAINANTE
14	1	O-RING
15	1	PIATTELLO
16	4	VITE
17	4	ANTIVIBRANTE

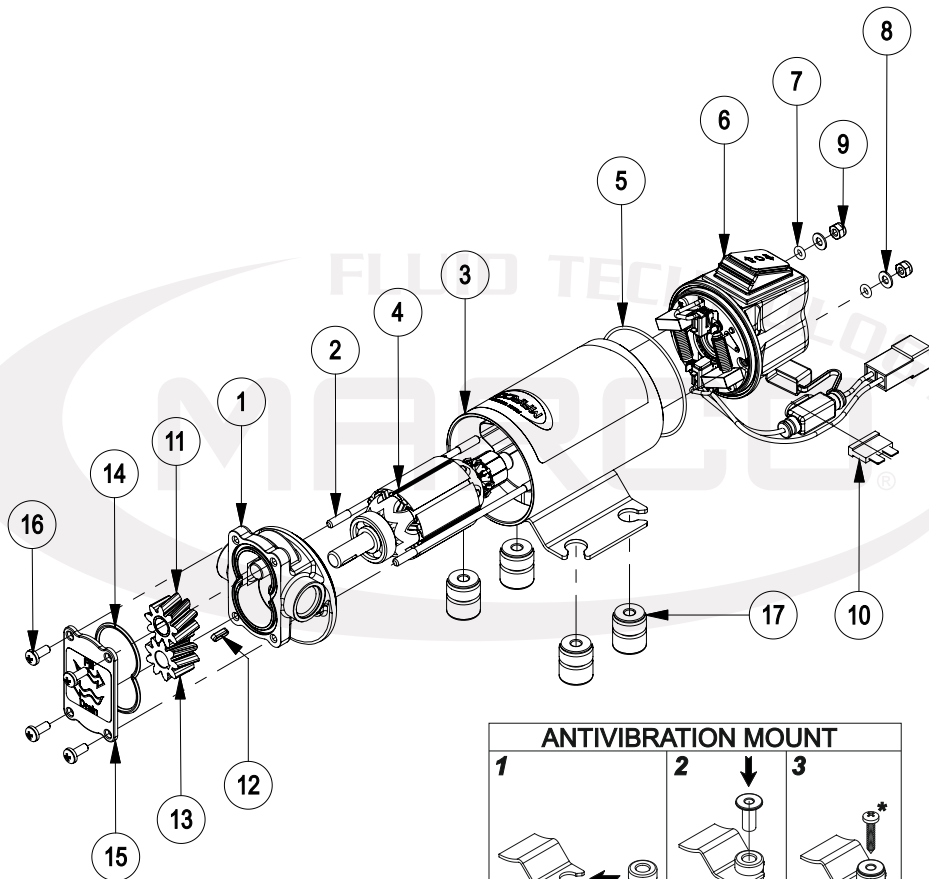

ANTIVIBRATION MOUNT

1	2	3

* VITI NON INCLUSE / SCREWS NOT INCLUDED

Pos.	Q.ty	Description
1	1	PUMP BODY
2	2	ROD
3	1	PUMP FRAME
4	1	ARMATURE
5	1	O-RING
6	1	BRUSH HOLDER
7	2	O-RING
8	2	WASHER
9	2	NUT

Pos.	Q.ty	Description
10	1	FUSE
11	1	IDLE GEAR
12	1	KEY
13	1	DRIVING GEAR
14	1	O-RING
15	1	TOP PLATE
16	4	SCREW
17	4	ANTIVIBRATION MOUNT

INGOMBRI / DIMENSIONS

mm [pollici / inches]

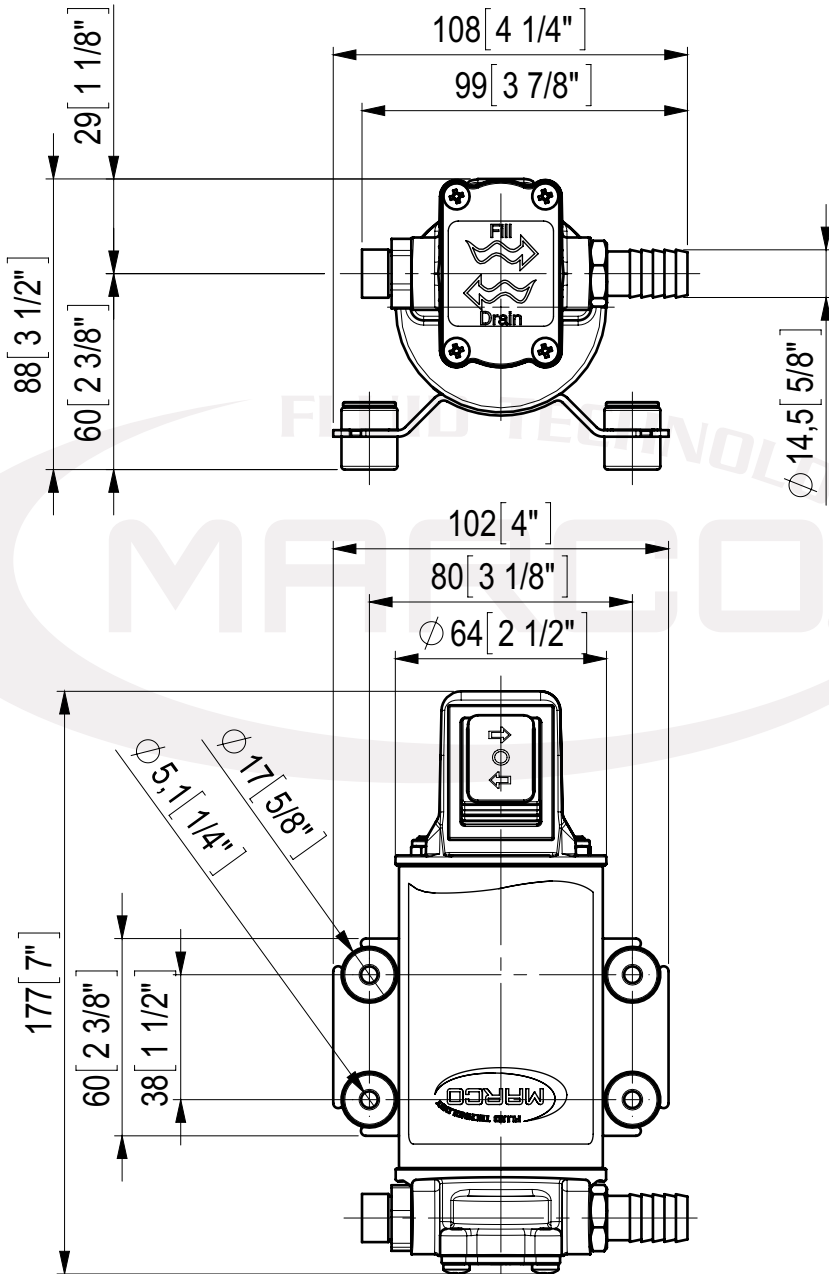

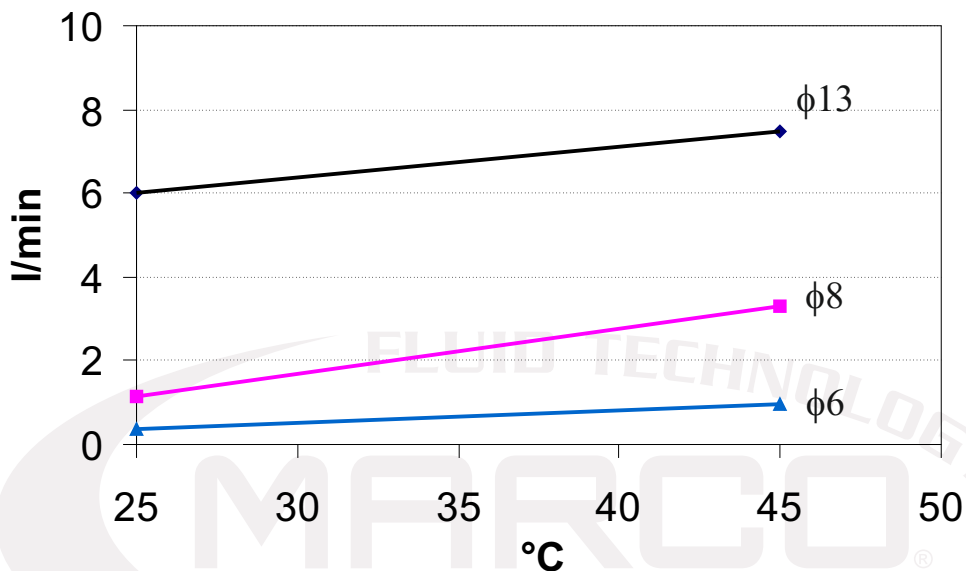
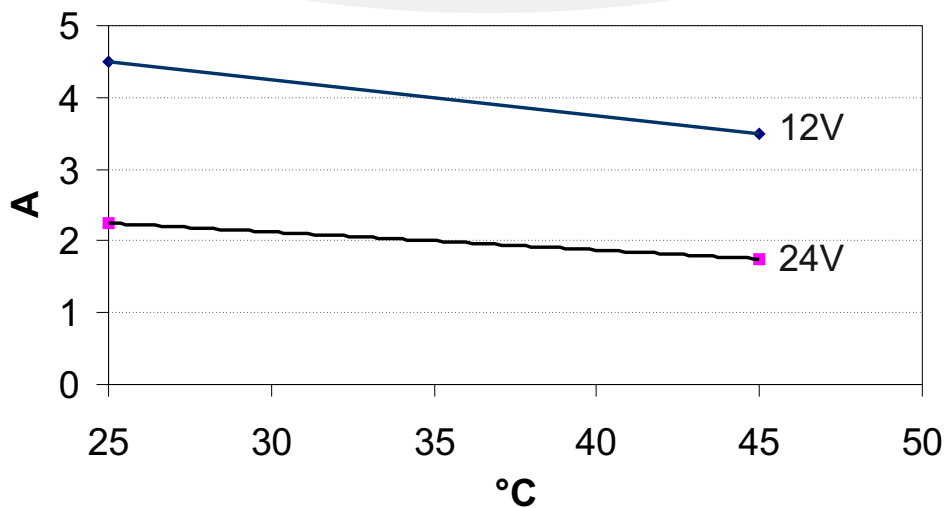
DIAGRAMMI / *DIAGRAM*DIAGRAMMA PORTATA
FLOW RATES DIAGRAMDIAGRAMMA ASSORBIMENTI
AMPERE-DRAW DIAGRAM



Assoc. AIB
Associazione
industriale
bresciana

DICHIARAZIONE DI CONFORMITA' C.E. E.C. DECLARATION OF CONFORMITY

Confermiamo che il prodotto:
We confirm that the product:

164 932 12 - OCK1-R 12V Kit cambio olio / Oil change kit

164 932 13 - OCK1-R 24V Kit cambio olio / Oil change kit

E' conforme alla Direttiva 2004/108/CE (ex.89/336/CE) relativa alla Compatibilità Elettromagnetica.
Is in conformity with the Directive 2004/108/EC (ex.89/336/EC) relating to Electromagnetic Compatibility.

Questa dichiarazione è valida per tutti gli articoli prodotti secondo la documentazione tecnica che è parte di questa dichiarazione. In caso di eventuali verifiche pertinenti alla Compatibilità Elettromagnetica sono state applicate le seguenti normative:

This declaration is valid for all products which are produced in accordance with the technical documentation which is a part of this declaration. For verification of conformity with regard to Electromagnetic Compatibility the following standards are applied:

EN 55014-1

Compatibilità elettromagnetica.
Requisiti per gli elettrodomestici,
gli utensili elettrici ed apparecchi simili.
Parte 1: Emissione.

*Electromagnetic compatibility.
Requirements for household appliances,
electric tools, and similar apparatus.
Part 1: Emission.*

Questa dichiarazione è rilasciata sotto la responsabilità esclusiva di:
This declaration is given under the sole responsibility of:

MARCO S.P.A.
Via Mameli 10 - 25014 Castenedolo - Brescia - Italy
Tel. 030/2134.1 Fax 030/2134.300

NOTE / NOTES

Handwriting practice area with horizontal dashed lines.





Questo documento e' proprieta' di Marco S.p.A la riproduzione e l'uso sono vietati.

Tutti i diritti sono riservati.

Per ulteriori informazioni vedere nostro sito internet - www.marco.it

Marco S.p.A Via Mameli 10 - 25014 Castenedolo (Brescia) – Italia

tel. +39 030 2134.1 / Fax +39 030 2134.300

Property of MARCO S.p.A reproduction prohibited. All rights reserved.

For further information visit our web site - www.marco.it

Marco S.p.A Via Mameli 10 - 25014 Castenedolo (Brescia) – Italy

tel. +39 030 2134.1 / Fax +39 030 2134.300