

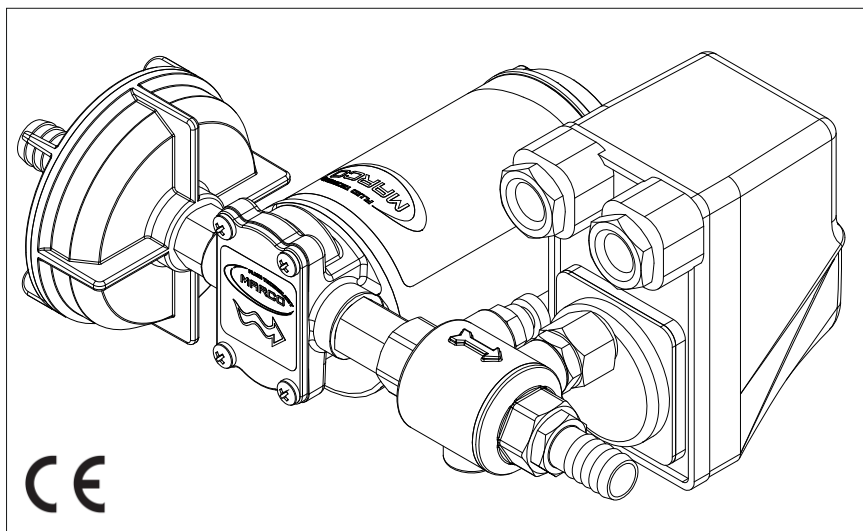

**ELETTROPOMPA AUTOADESCANTE  
PER TRAVASO LIQUIDI  
SELF-PRIMING ELECTRIC PUMP  
FOR TRANSFERRING VARIOUS LIQUIDS**

**AVVERTENZE D'USO  
INSTRUCTIONS FOR USE**

**164 600 12 - UP3/A 12V  
164 600 13 - UP3/A 24V**



## PRODUCT DESCRIPTION

A

Self-priming gear pump with in line filter, check valve and pressure switch: to be used as automatic pump for boats, trucks, camper, etc.

Brass body, PTFE gears, stainless-steel shaft and lip seal. The pressure switch is preset at 2,5 bar.

We suggest to install an accumulator tank.

## TECHNICAL DETAILS

B

| CODE       | TYPE  | FLOW RATE | PRESSURE | FUSE  | WEIGHT | PCS x CART. |
|------------|-------|-----------|----------|-------|--------|-------------|
| 164 600 12 | UP3/A | 15 l/min  | 2,5 bar  | 10 A  | 2,3 kg | 6           |
| 164 600 13 |       |           |          | 7,5 A |        |             |

## AMBIENT CONDITIONS

C

**TEMPERATURE:** min.-10°C 14°F-max.60°C 140°F **RELATIVE HUMIDITY:** max. 90 %

**⚠ WARNING:** the above indicated temperature ranges are applicable to all components of the pump and these limits must be respected in order to avoid any possible damage or malfunctioning.

## OPERATING CYCLE

D

The pump has been designed for discontinuous use. Under conditions of high operating pressures (eg. with closed or blocked outlet, excessive length of the delivery circuit and/or excessive pressure due to accessories), it can be subjected to elevated stresses and overheating and therefore should not be used for prolonged periods under such conditions.

## APPLICATIONS

E

There are numerous fields of applications for the pump, however only exclusively with the allowed liquids mentioned:

- Main use as automatic pump for drinkable and sanitary water systems on boats, camper.

## F FLUIDS ALLOWED / NOT ALLOWED

### ALLOWED:

FRESH WATER AND SEA WATER (max 40°C)

### NOT ALLOWED:

- PETROL (GASOLINE)
- FLAMMABLE LIQUIDS with PM < 55°C
- LIQUIDS WITH VISCOSITY > 20 cSt
- FOODSTUFF LIQUIDS
- CORROSIVE CHEMICAL PRODUCTS
  
- SOLVENTS

### RELATED DANGERS

- FIRE EXPLOSION
- FIRE EXPLOSION
- MOTOR OVERHEATING
- FOODSTUFF LIQUID CONTAMINATION
- PUMP CORROSION
- INJURY TO PERSONNEL
- FIRE EXPLOSION
- DAMAGE TO SEALS

**WARRANTY EXPIRES IF MAX FLUID TEMPERATURE IS EXCEEDED**

## G TRANSPORTATION AND HANDLING

Due to limited weight and dimensions the pump does not require the use of any special handling or lifting equipment. When handling manually, normal personal protective gear should be worn (safety shoes with toe piece, etc.)

The pump is carefully packed prior to shipment. Upon receiving, the pump packaging should be inspected for damages and the pump stored in a dry area.

## H INSTALLATION

It is recommended that the use of the pump be according to normative safety standards and also as per the precautions listed below.

### H-1 PRELIMINARY CHECKS

Check that there has been no damage to the pump during transportation or storage. Both inlet and outlet ports should be carefully cleaned removing possible dust or residual packaging material. Verify that the available electrical power supply corresponds to the pump specification requirements.

### H-2 POSITIONING

The pump can be mounted in any position. Fix the pump utilizing suitable screws corresponding to the antivibration mounts supplied with the pump.

**WARNING: THE PUMP MOTOR IS NOT EXPLOSION PROOF**

Do not install the pump where flammable vapours or gases may be present. Install the pump in an accessible place for inspection.

It is good practice to avoid any pump contact with water splashes possibly causing water seepage into the motor with high risk of internal oxidation and/or short circuit.

**TUBING CONNECTIONS****H-3**

- Prior to making any tube/hose connections, check that the inlet ports have no end caps.
- Do not position the pump at a height greater than 1,5 m with respect to the minimum level of the fluid to be transferred. Pump damage may occur if this height is exceeded as the pump may not draw fluid. Make sure that the outlet tube is empty and without chokes.
- Avoid choking the inlet or outlet tubes so that pump efficiency is optimized. The use of an inlet filter is mandatory especially with fluids containing impurities. In this case frequent cleaning and maintenance of the filter is advisable. Utilize tubes and connection pieces that are resistant to the fluid types handled and avoid any possible environmental dispersion.

**ELECTRICAL CONNECTION****H-4**

The electrical installation of the pump must include a protection fuse which is suitably rated as indicated on the motor label.

**WARRANTY EXPIRES IF NO FUSE IS UTILIZED**

Always mount the anti vibration rubber fittings supplied with the pump kit. Their usage ensures a consistent reduction in noise and vibration levels.

Electrical cabling size should depend on the distance between pump and battery power supply.

Up to 4 m length: 2,5 mm<sup>2</sup>

The use of undersized cabling can cause overheating of the electrical wiring and subsequent fire hazard. There will also be a voltage drop at the motor terminals with a consequent reduction in efficiency.

The flow rate value indicated on the motor label is obtained with a 13 mm internal tube diameter. Tubes with inferior diameters will cause an increase in current with potential risk of motor overheating.

To ensure the correct directional flow of the fluid as indicated by the arrow on the top of the pump, it is necessary to connect the positive pole of the battery supply to the red wire ( + ) on the motor end-cap and the negative pole to the black wire ( - ). Electrical connections must be made using adequate terminal blocks and connectors ensuring a tight fitment of the electrical cables. Bad wiring can cause power losses and/or overheating of the cabling itself.



**WARNING:** it is the responsibility of the installation technician to ensure a correctly designed circuit installation fitted according to regulations. Environmental risks must be taken into account with the installation.

## I TROUBLESHOOTING

### I-1 CHECK POINTS IF THE PUMP HAS STOPPED OR WILL NOT START

- Check the effectiveness of the battery power supply (voltage activity)
- Check if the fuse has blown
- Check for any foreign matter present in pump body: disconnect the power supply and unscrew the fixing screws, remove the pump front cover plate and inspect the pump chamber. Replace the cover plate in the same initial position after inspection.
- Avoid running the pump dry for more than a few minutes. Pumps found defective that have run dry in the absence of fluid are not covered by warranty.
- The average life span of the motor commutator brushes is approximately 1500 hours under normal operating conditions. Stoppages are possible due to brush wear and tear after such a time period.

### I-2 WHY THE PUMP WILL NOT PRIME ITSELF?

- The pump is fitted at a height greater than 1,5 m above the fluid level.
- The pump has run dry for too long a period
- Long periods of inactivity. In this case it is advisable to add liquid directly into the pump chamber before start-up. It is also advisable to add, before running the pump, a drop of lubricating oil inside the pump only.
- Air leak at the suction pipe due to the following reasons:
  - Possible cuts in the pipe, inadequate hose clamps, filter clogged.
- Air leak at the pump front plate cover due to the following reasons:
  - Loose fixing screws, poor effectiveness/damage of the seal.
  - Bypass valve damaged.
  - Faulty electrical cable connections
- Presence of obstructions or restrictions in the suction or delivery pipes or the use of special devices(eg. automatic spray pistol or aqua-stop).
- Presence of liquid loops in the outlet tube.

### I-3 GOOD PRACTICES ENSURING A WELL FUNCTIONING PUMP

No particular maintenance is required if the pump is utilized for the transfer of diesel fluids. If it is expected that the pump will not be used for a period of at least 30 days, it is advisable to loosen the pump front plate screws. Upon re-use, run the pump briefly (a few seconds) and tighten the screws again. Check under conditions of maximum operating pressure that the motor current value is within the motor label specifications.

**NORMAL MAINTENANCE**

I-4

- Check frequently and keep the inlet filter clean.
- Check every month the pump chamber and keep clean from any foreign matter.
- Check every month that electrical wiring is in good condition.
- Every 1500 hours of pump operation check the motor brushes.

**INDICATORS THAT THE PUMP IS FUNCTIONING CORRECTLY**

I-5

- Temperature of pump body and motor frame is within 60°C - 70°C.
- Regular flow and constant pump noise levels.
- Amp-draw within the limits indicated in the technical details.

**TO OPEN THE PUMP**

I-6

- It is recommended that a specialized service technician be consulted for any pump repair work or the replacement of worn out internal components, exclusively with original spare parts.
- During the warranty period, only by authorized Marco S.p.A. personnel, failing which the warranty will expire.

**ENVIRONMENTAL DISPOSAL**

L

Do not dispose of pumps into household waste: pumps that are no longer usable, must be collected separately and disposed of in an environmentally correct manner.

**PACKAGING ENVIRONMENTAL DISPOSAL**

L-1

The user is invited to effect a proper waste separation, in order to facilitate the recycling of the materials of which the packing is composed; disposal like CER 15.01.01/02

**WARRANTY**

M

- 1) The Warranty period is 2 years from date of purchase on production of the appropriate sales invoice.
- 2) Should the original sales invoice not be available, then the 2 year warranty period will be valid from date of production.
- 3) The Warranty becomes null and void in the case of incorrect utilization or disregard of the instructions contained herein.
- 4) The Warranty only covers original production defects.
- 5) The Warranty does not cover any related installation costs involved.
- 6) Transport costs are refundable only in the case where warranty has been duly recognized and accepted by Marco Spa. These costs will be limited to the actual shipment costs between Marco Spa warehouse and the client's delivery address.
- 7) No credit notes or replacement items will be issued prior to the receipt and proper testing of any Marco goods that are deemed faulty.

# N SCHEDA DI ASSEMBLAGGIO / EXPLODED VIEW

| Pos. | Q.tà | Descrizione                |
|------|------|----------------------------|
| 1    | 1    | CORPO CON ANELLO DI TENUTA |
| 2    | 2    | O-RING                     |
| 3    | 2    | TIRANTE                    |
| 4    | 1    | CARCASSA                   |
| 5    | 1    | INDOTTO                    |
| 6    | 1    | CALOTTA                    |
| 7    | 2    | O-RING                     |
| 8    | 2    | RONDELLA                   |
| 9    | 2    | DADO                       |
| 10   | 1    | NIPPLO                     |
| 11   | 6    | O-RING                     |
| 12   | 1    | VALVOLA DI NON RITORNO     |
| 13   | 1    | VALVOLA DI SFIATO          |

| Pos. | Q.tà | Descrizione           |
|------|------|-----------------------|
| 14   | 1    | NIPPLO                |
| 15   | 1    | PRESSOSTATO           |
| 16   | 1    | INGRANAGGIO FOLLE     |
| 17   | 1    | LINGUETTA             |
| 18   | 1    | INGRANAGGIO TRAINANTE |
| 19   | 1    | O-RING                |
| 20   | 1    | PIATTELLO             |
| 21   | 4    | VITE                  |
| 22   | 2    | PORTAGOMMA            |
| 23   | 1    | NIPPLO                |
| 24   | 1    | FILTRO                |
| 25   | 4    | ANTIVIBRANTE          |

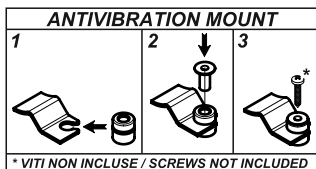
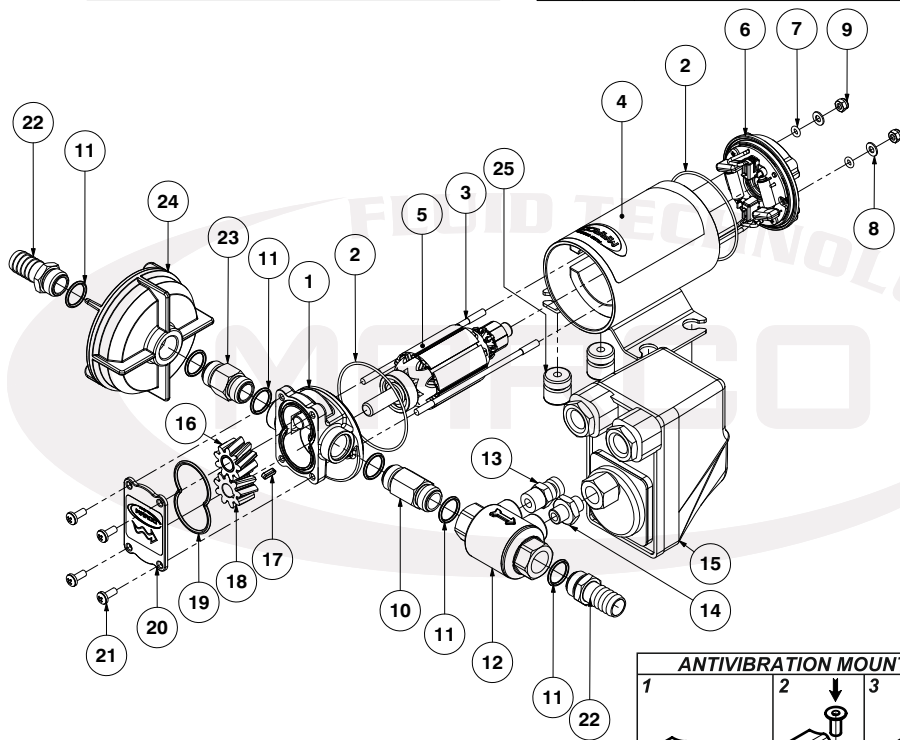

| Pos. | Q.ty | Description         |
|------|------|---------------------|
| 1    | 1    | PUMP BODY WITH SEAL |
| 2    | 2    | O-RING              |
| 3    | 2    | ROD                 |
| 4    | 1    | PUMP FRAME          |
| 5    | 1    | ARMATURE            |
| 6    | 1    | BRUSH HOLDER        |
| 7    | 2    | O-RING              |
| 8    | 2    | WASHER              |
| 9    | 2    | NUT                 |
| 10   | 1    | NIPPLE              |
| 11   | 6    | O-RING              |
| 12   | 1    | NON RETURN VALVE    |
| 13   | 1    | AIR VENT VALVE      |

| Pos. | Q.ty | Description         |
|------|------|---------------------|
| 14   | 1    | NIPPLE              |
| 15   | 1    | PRESSURE SWITCH     |
| 16   | 1    | IDLE GEAR           |
| 17   | 1    | KEY                 |
| 18   | 1    | DRIVING GEAR        |
| 19   | 1    | O-RING              |
| 20   | 1    | TOP PLATE           |
| 21   | 4    | SCREW               |
| 22   | 2    | TUBE OUTLET         |
| 23   | 1    | NIPPLE              |
| 24   | 1    | FILTER              |
| 25   | 4    | ANTIVIBRATION MOUNT |

# INGOMBRI / DIMENSIONS

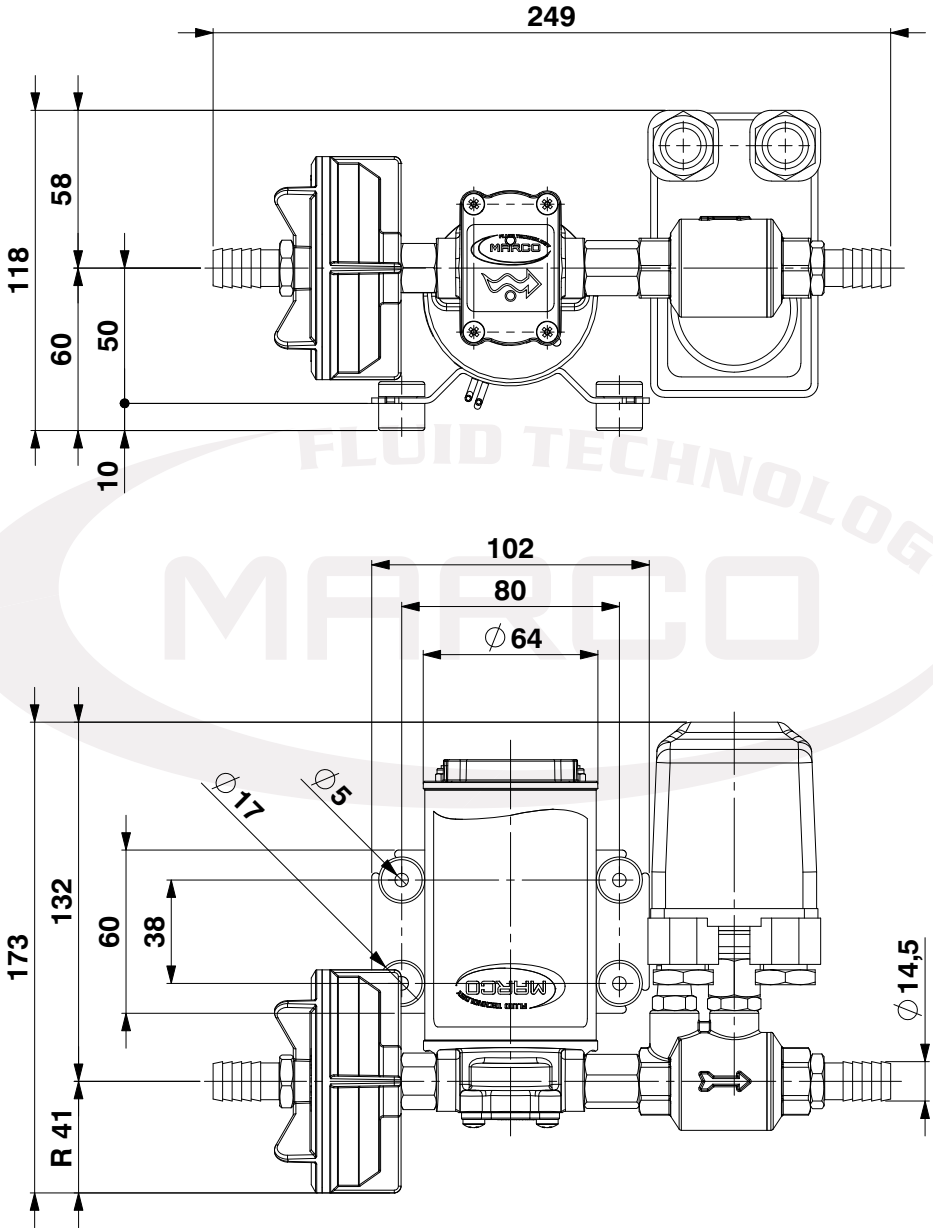

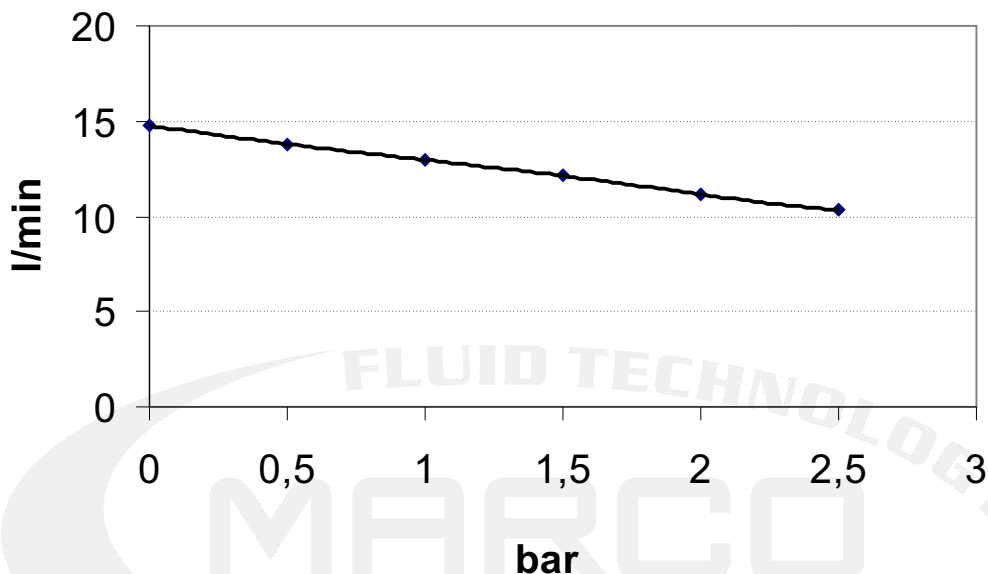
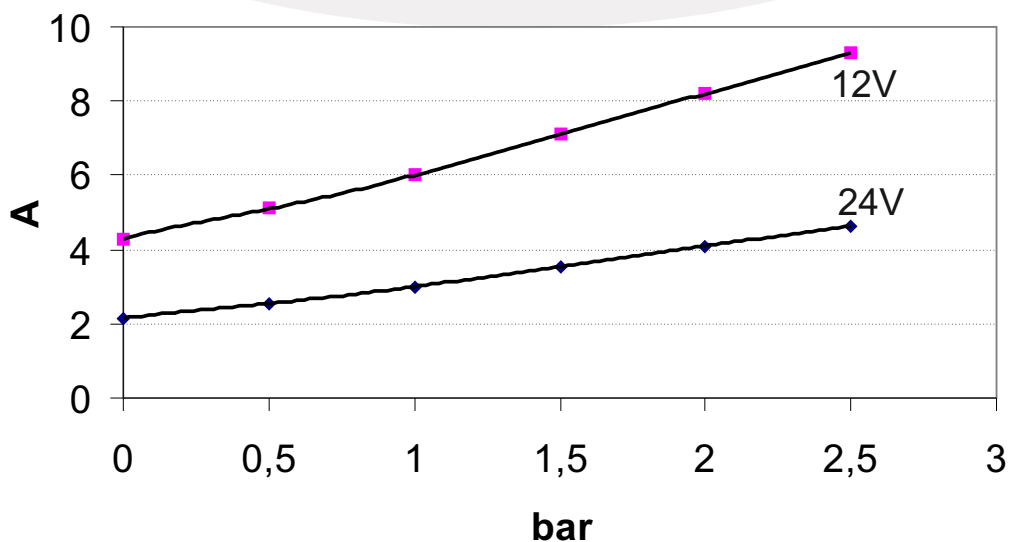

**DIAGRAMMI / DIAGRAM****DIAGRAMMA PORTATA  
FLOW RATES DIAGRAM****DIAGRAMMA ASSORBIMENTI  
AMPERE-DRAW DIAGRAM**



Associato AIB  
Associazione  
industriale  
bresciana

## DICHIARAZIONE DI CONFORMITA' C.E. E.C. DECLARATION OF CONFORMITY

Confermiamo che il prodotto:  
*We confirm that the product:*

**164 600 12 - UP3/A 12V Pompa automatica ad ingranaggi 15 l / Automatic Gear pump**

**164 600 13 - UP3/A 24V Pompa automatica ad ingranaggi 15 l / Automatic Gear pump**

E' conforme alla Direttiva 2004/108/CE (ex.89/336/CE) relativa alla Compatibilità Elettromagnetica.  
*Is in conformity with the Directive 2004/108/EC (ex.89/336/EC) relating to Electromagnetic Compatibility.*

Questa dichiarazione è valida per tutti gli articoli prodotti secondo la documentazione tecnica che è parte di questa dichiarazione. In caso di eventuali verifiche pertinenti alla Compatibilità Elettromagnetica sono state applicate le seguenti normative:

*This declaration is valid for all products which are produced in accordance with the technical documentation which is a part of this declaration. For verification of conformity with regard to Electromagnetic Compatibility the following standards are applied:*

EN 55014-1

Compatibilità elettromagnetica.  
Requisiti per gli elettrodomestici,  
gli utensili elettrici ed apparecchi simili.  
Parte 1: Emissione.

*Electromagnetic compatibility.  
Requirements for household appliances,  
electric tools, and similar apparatus.  
Part 1: Emission.*

Questa dichiarazione è rilasciata sotto la responsabilità esclusiva di:  
*This declaration is given under the sole responsibility of:*

**MARCO S.P.A.**  
Via Mameli 10 - 25014 Castenedolo - Brescia - Italy  
Tel. 030/2134.1 Fax 030/2134.300

Per ulteriori informazioni vedere nostro sito internet - [www.marco.it](http://www.marco.it)  
Marco S.p.A Via Mameli 10 - 25014 Castenedolo - Brescia - Italia  
tel. +39 030 2134.1 / Fax +39 030 2134.300

For further information visit our web site - [www.marco.it](http://www.marco.it)  
Marco S.p.A Via Mameli 10 - 25014 Castenedolo - Brescia - Italy  
tel. +39 030 2134.1 / Fax +39 030 2134.300