

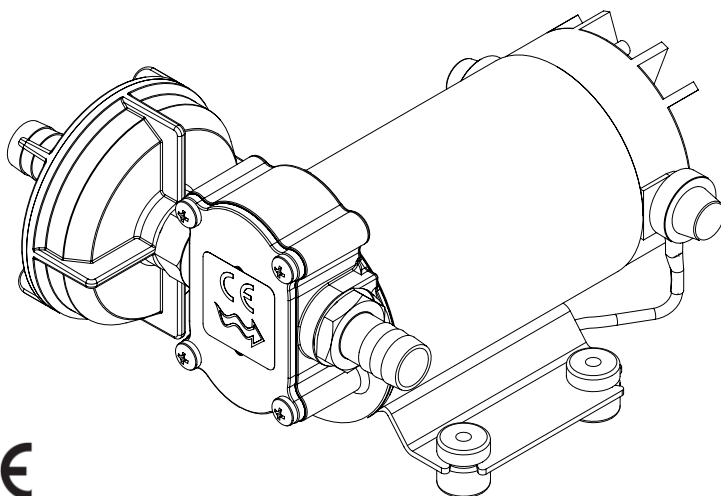

**ELETTROPOMPA AUTOADESCANTE  
PER TRAVASO LIQUIDI  
SELF-PRIMING ELECTRIC PUMP  
FOR TRANSFERRING VARIOUS LIQUIDS**

**AVVERTENZE D'USO  
INSTRUCTIONS FOR USE**

**164 065 12 - UP6-P 12V  
164 065 13 - UP6-P 24V**



**CE**

07/02/14 Rev.03

## PRODUCT DESCRIPTION

A

Self-priming electric pump for the transfer of liquids of varied nature (except those listed in section G) for discontinuous or intermittent usage.

The pumping elements are made up of PTFE gear drives which can possibly even run dry for brief periods.

Completely equipped with in-line filter on the inlet side.

## TECHNICAL DETAILS

B

CODE	TYPE	VOLT	FUSE	FLOW RATE	PRESSURE	WEIGHT	P.CS x CART.
164 065 12	UP6-P	12	15 A	26 l/min	2 bar	3 kg	6
164 065 13		24	7,5 A				

## AMBIENT CONDITIONS

C

**TEMPERATURE:** min. -10 °C / max. +60 °C      **RELATIVE HUMIDITY:** max. 90 %

**⚠ WARNING:** the above indicated temperature ranges are applicable to all components of the pump and these limits must be respected in order to avoid any possible damage or malfunctioning.

## ELECTRICAL CONNECTIONS

D

The electric pump must be connected to a source of direct current (either battery or DC power supply) with an amp rating of 15A (12V) and 7,5A (24V).

The pump must be protected by suitable rated fuse.

## OPERATING CYCLE

E

The pump has been designed for discontinuous use. Under conditions of high operating pressures (eg. with closed or blocked outlet, excessive length of the delivery circuit and/or excessive pressure due to accessories), the pump can be subjected to elevated stresses and overheating and therefore should not be used for prolonged periods under such conditions.

## APPLICATIONS

F

There are numerous fields of applications for the pump, however only exclusively with the allowed liquids mentioned:

- transfer of diesel fuel between tanks, refuelling of tractors and earth moving Equipment;
- bilge pump for boats;
- water pressure system;
- transfer of light weight lube oils, antifreeze, etc.

## G FLUIDS ALLOWED / NOT ALLOWED

### ALLOWED:

FRESH WATER, SALT WATER (max 40°C-104°F)  
DIESEL FUEL minimum flashpoint (PM): 55°C-131°F.

### NOT ALLOWED:

- PETROL (GASOLINE)
- FLAMMABLE LIQUIDS with PM < 131°F
- LIQUIDS WITH VISCOSITY > 20 cSt
- FOODSTUFF LIQUIDS
- CORROSIVE CHEMICAL PRODUCTS
  
- SOLVENTS

### RELATED DANGERS

- FIRE EXPLOSION
- FIRE EXPLOSION
- MOTOR OVERHEATING
- FOODSTUFF LIQUID CONTAMINATION
- PUMP CORROSION
- INJURY TO PERSONNEL
- FIRE EXPLOSION
- DAMAGE TO SEALS

**WARRANTY EXPIRES IF MAX FLUID TEMPERATURE IS EXCEEDED**

## H TRANSPORTATION AND HANDLING

Due to limited weight and dimensions the pump does not require the use of any special handling or lifting equipment. When handling manually, normal personal protective gear should be worn (safety shoes with toe piece, etc.)

The pump is carefully packed prior to shipment. Upon receiving, the pump packaging should be inspected for damages and the pump stored in a dry area.

## I INSTALLATION

It is recommended that the use of the pump be according to normative safety standards and also as per the precautions listed below.

### I-1 PACKAGING ENVIRONMENTAL DISPOSAL

The user is invited to effect a proper waste separation, in order to facilitate the recycling of the materials of which the packing is composed; disposal like CER 15.01.01/02

### I-2 PRELIMINARY CHECKS

Check that there has been no damage to the pump during transportation or storage. Both inlet and outlet ports should be carefully cleaned removing possible dust or residual packaging material. Verify that the available electrical power supply corresponds to the pump specification requirements.

### I-3 POSITIONING OF THE PUMP

The pump can be mounted in any position. Fix the pump utilizing suitable screws corresponding to the antivibration mounts supplied with the pump.

- ⚠ WARNING: THE PUMP MOTOR IS NOT EXPLOSION PROOF**  
 Do not install the pump where flammable vapours or gases may be present. Install the pump in an accessible place for inspection.  
 It is good practice to avoid any pump contact with water splashes possibly causing water seepage into the motor with high risk of internal oxidation and/or short circuit.

## TUBING CONNECTIONS

I-4

- Prior to making any tube/hose connections, check that the inlet ports have no end caps;
- Do not position the pump at a excessive height with respect to the minimum level of the fluid to be transferred. Damage may occur if this height is exceeded as the pump may not draw fluid. Make sure that the outlet tube is empty and without chokes;
- Avoid choking the inlet or outlet tubes so that efficiency is optimized.
- The use of an inlet filter is recommended especially with fluids containing impurities (ASTM mesh 35). In this case frequent cleaning and maintenance of the filter is advisable. The standard filter withstands a maximum positive pressure of 0.5 bar.
- Utilize tubes and connection pieces that are resistant to the fluid types handled and avoid any possible environmental dispersion.

## PUMP INSTALLATION

I-5

The electrical installation of the pump must include a protection fuse which is suitably rated as indicated on the motor label.

### **WARRANTY      EXPIRES      IF      NO      FUSE      IS      UTILIZED**

Always mount the anti vibration rubber fittings supplied with the pump kit. Their usage ensures a consistent reduction in noise and vibration levels.  
 Electrical cabling size should depend on the distance between pump and battery power supply.

Up to 4 m length: 4 mm<sup>2</sup>

The use of undersized cabling can cause overheating of the electrical wiring and subsequent fire hazard. There will also be a voltage drop at the motor terminals with a consequent reduction in efficiency.

The flow rate value indicated on the motor label is obtained with a 16 mm internal tube diameter. Tubes with inferior diameters will cause an increase in current with potential risk of motor overheating.

To ensure the correct directional flow of the fluid as indicated by the arrow on the top of the pump, it is necessary to connect the positive pole of the battery supply to the red wire ( + ) on the motor end-cap and the negative pole to the black wire ( - ). Electrical connections must be made using adequate terminal blocks and connectors ensuring a tight fitment of the electrical cables. Bad wiring can cause power losses and/or overheating of the cabling itself.

 **WARNING:** it is the responsibility of the installation technician to ensure a correctly designed circuit installation fitted according to regulations. Environmental risks must be taken into account with the installation.

L

## TROUBLESHOOTING

### L-1 CHECK POINTS IF THE PUMP HAS STOPPED OR WILL NOT START

- Check the effectiveness of the battery power supply (voltage activity);
- Check if the fuse has blown;
- Check for any foreign matter present in-between the pump gear drives. To do this, disconnect the power supply and unscrew the four fixing screws, remove the pump front cover plate and inspect the pump chamber. Replace the cover plate in the same initial position after inspection;
- Avoid running the pump dry for more than a few minutes. Pumps found defective that have run dry in the absence of fluid are not covered by warranty;
- The average life span of the motor commutator brushes is approximately 700 hours under normal operating conditions. Stoppages are possible due to brush wear and tear after such a time period.

L-2

### WHY THE PUMP WILL NOT PRIME ITSELF?

- The pump is fitted at a height greater than 1,5 m above the fluid level;
- The pump has run dry for too long a period;
- Long periods of inactivity. In this case it is advisable to add liquid directly into the pump chamber before start-up. It is also advisable to add, before running the pump, a drop of Lubricating oil inside the pump only;
- Air leak at the suction pipe due to the following reasons:  
possible cuts in the pipe, inadequate hose clamps, malfunctioning of the filter due to defective/worn seals or filter clogged.
- Air leak at the pump front plate cover due to the following reasons:  
loose fixing screws, poor effectiveness of the seal;
- Faulty electrical cable connections;
- Presence of obstructions or restrictions in the suction or delivery pipes or the use of special devices(eg. automatic spray pistol or aqua-stop);
- Presence of liquid loops in the outlet tube.

L-3

### GOOD PRACTICES ENSURING A WELL FUNCTIONING PUMP

No particular maintenance is required if the pump is utilized for the transfer of diesel fluids. If it is expected that the pump will not be used for a period of at least 30 days, especially in the case of usage with fresh or salty water, it is advisable to run fresh water through the pump and to then loosen the pump front plate screws.

Upon re-use, run the pump briefly (a few seconds) and then tighten the screws again. Check under conditions of maximum operating pressure that the motor current value is within the motor label specifications.

## NORMAL MAINTENANCE

L-4

- Check frequently and keep the inlet filter clean.
- Check every month the pump chamber and keep clean from any foreign matter.
- Check every month that electrical wiring is in good condition.
- Every 700 hours of pump operation substitute the motor brushes.
- Every season check the mechanic of the pressure switch and keep it lubricated.

## INDICATORS THAT THE PUMP IS FUNCTIONING CORRECTLY

L-5

- Temperature of pump body and motor frame is within 60°C - 70°C;
- Regular flow and constant pump noise levels;
- Amp-draw within the limits indicated in the technical details.

## TO OPEN THE PUMP

L-6

It is recommended that a specialized service technician be consulted for any pump repair work or the replacement of worn out internal components, exclusively with original spare parts;

During the warranty period, only by authorized Marco S.p.A. personnel, failing which the warranty will expire.

## ENVIRONMENTAL DISPOSAL

M

Do not dispose of pumps into household waste. Pumps that are no longer usable, must be collected separately and disposed of in an environmentally correct manner.

## WARRANTY

N

1. The Warranty period is 2 years from date of purchase on production of the appropriate sales invoice.
2. Should the original sales invoice not be available, then the 2 year warranty period will be valid from production date.
3. The Warranty becomes null and void in the case of incorrect utilization or disregard of the instructions contained herein.
4. The Warranty only covers original production defects.
5. The Warranty does not cover any related installation costs involved.
6. Transport costs are refundable only in the case where warranty has been duly recognized and accepted by Marco Spa. These costs will be limited to the actual shipment costs between Marco Spa warehouse and the client's delivery address.
7. No credit notes or replacement items will be issued prior to the receipt and proper testing of any Marco goods that are deemed faulty.

# SCHEDA DI ASSEMBLAGGIO / EXPLODED VIEW

Pos.	Q.tà	Descrizione
1	1	CORPO
2	1	ANELLO DI TENUTA
3	2	TIRANTE
4	1	INDOTTO
5	1	CARCASSA
6	1	CUSCINETTO
7	1	ANELLO ONDULATO
8	1	CALOTTA
9	2	RONDELLA
10	2	DADO
11	2	SPAZZOLA
12	2	TAPPO

Pos.	Q.tà	Descrizione
13	1	INGRANAGGIO FOLLE
14	1	LINGUETTA
15	1	INGRANAGGIO TRAINANTE
16	1	O-RING
17	1	PIATTELLO
18	4	VITE
19	1	NIPPOLO
20	4	O-RING
21	2	PORTAGOMMA
22	1	FILTRO
23	4	ANTIVIBRANTE

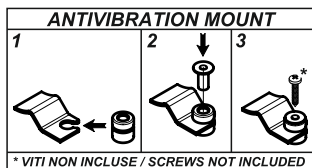
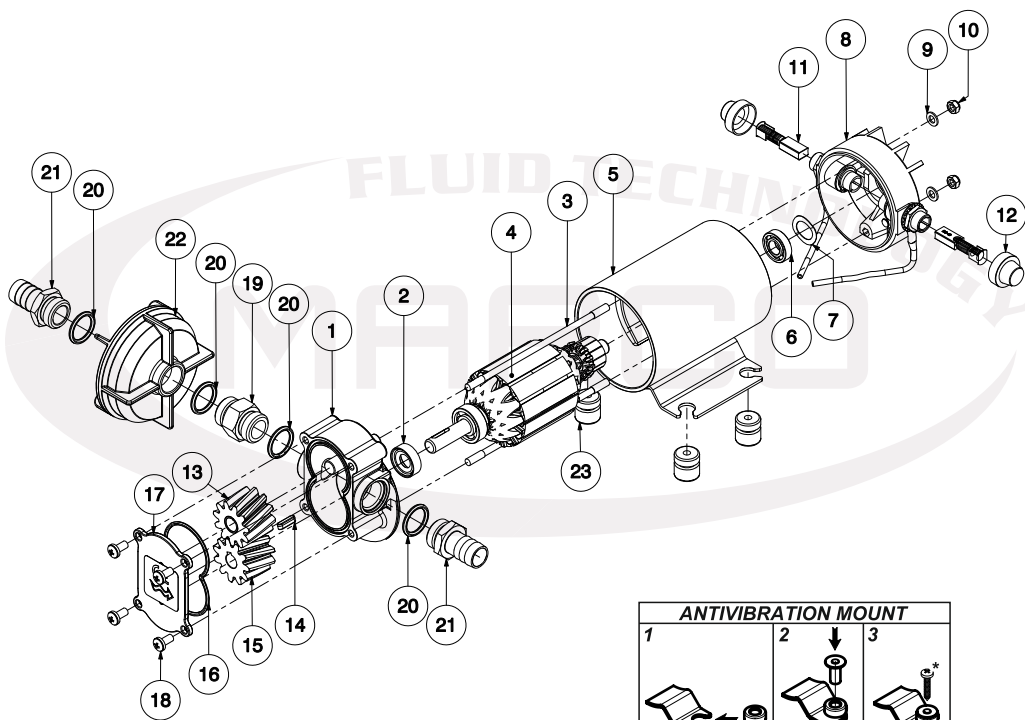

Pos.	Q.ty	Description
1	1	PUMP BODY
2	1	LIP SEAL
3	2	ROD
4	1	ARMATURE
5	1	PUMP FRAME
6	1	BALL BEARING
7	1	COMPENSATION SPRING
8	1	BRUSH HOLDER
9	2	WASHER
10	2	NUT
11	2	BRUSH
12	2	CAP

Pos.	Q.ty	Description
13	1	IDLE GEAR
14	1	KEY
15	1	DRIVING GEAR
16	1	O-RING
17	1	TOP PLATE
18	4	SCREW
19	1	NIPPLE
20	4	O-RING
21	2	TUBE OUTLET
22	1	FILTER
23	4	ANTIVIBRATION MOUNT

# INGOMBRI / DIMENSIONS

P

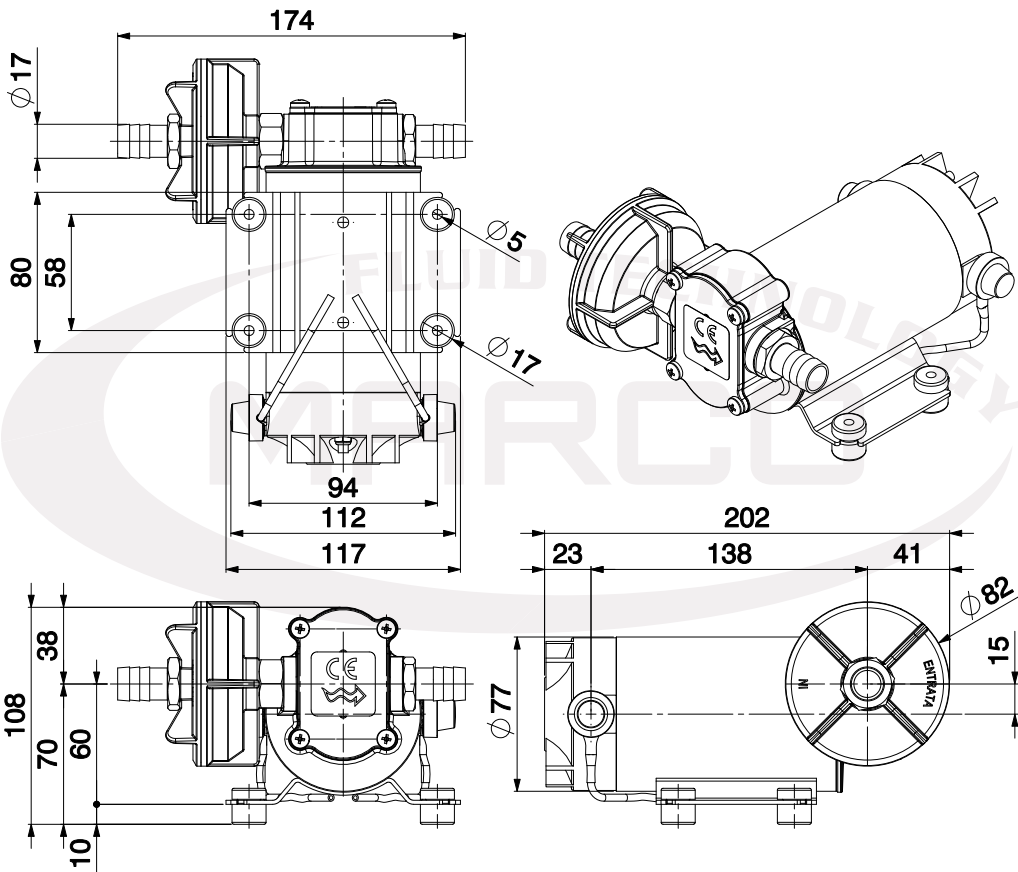

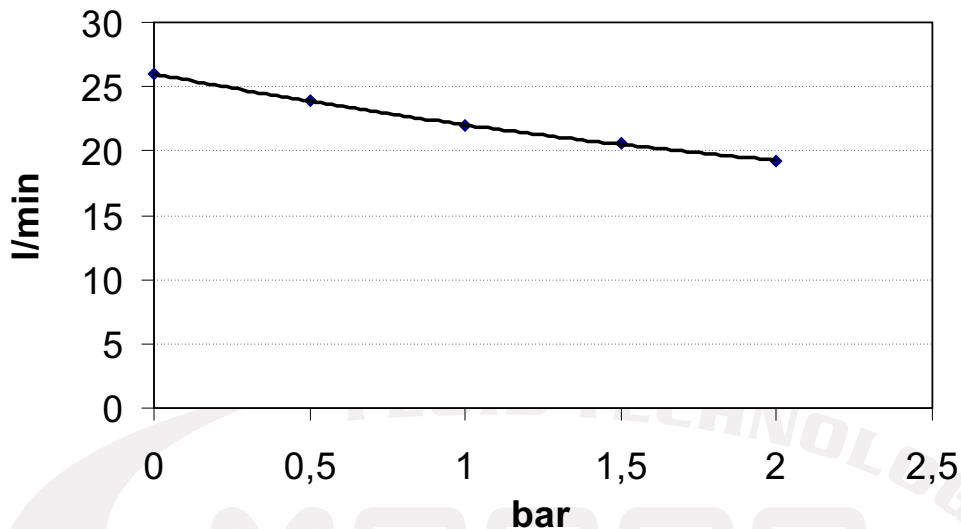
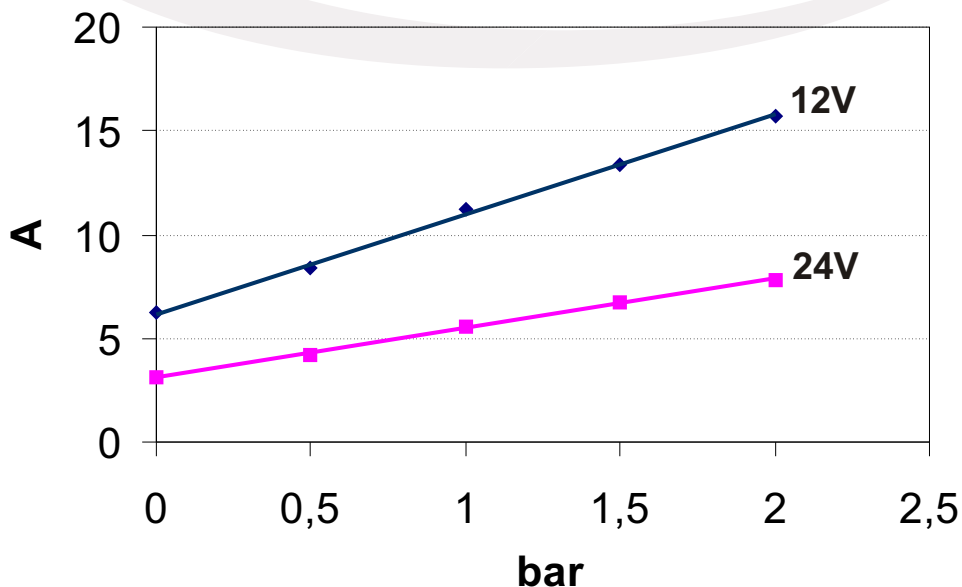

## DIAGRAMMI / DIAGRAMS

DIAGRAMMA PORTATA  
FLOW RATES DIAGRAMDIAGRAMMA ASSORBIMENTI  
AMPERE-DRAW DIAGRAM



Associazione AIB  
Associazione  
Industriale  
Bresciana

## DICHIARAZIONE DI CONFORMITA' C.E. E.C. DECLARATION OF CONFORMITY

Confermiamo che il prodotto:  
*We confirm that the product:*

**164 065 12 - UP6-P 12V Pompa ad ingranaggi 26 l / Gear pump**

**164 065 13 - UP6-P 24V Pompa ad ingranaggi 26 l / Gear pump**

E' conforme alla Direttiva 2004/108/CE (ex.89/336/CE) relativa alla Compatibilità Elettromagnetica.  
*Is in conformity with the Directive 2004/108/EC (ex.89/336/EC) relating to Electromagnetic Compatibility.*

Questa dichiarazione è valida per tutti gli articoli prodotti secondo la documentazione tecnica che è parte di questa dichiarazione. In caso di eventuali verifiche pertinenti alla Compatibilità Elettromagnetica sono state applicate le seguenti normative:

*This declaration is valid for all products which are produced in accordance with the technical documentation which is a part of this declaration. For verification of conformity with regard to Electromagnetic Compatibility the following standards are applied:*

EN 55014-1

Compatibilità elettromagnetica.  
Requisiti per gli elettrodomestici,  
gli utensili elettrici ed apparecchi simili.  
Parte 1: Emissione.

*Electromagnetic compatibility.  
Requirements for household appliances,  
electric tools, and similar apparatus.  
Part 1: Emission.*

Questa dichiarazione è rilasciata sotto la responsabilità esclusiva di:  
*This declaration is given under the sole responsibility of:*

**MARCO S.P.A.**  
Via Mameli 10 - 25014 Castenedolo - Brescia - Italy  
Tel. 030/2134.1 Fax 030/2134.300

Questo documento e' proprieta' di Marco S.p.A la riproduzione e l'uso sono vietati.

Tutti i diritti sono riservati.

Per ulteriori informazioni vedere nostro sito internet - [www.marco.it](http://www.marco.it)

Marco S.p.A Via Mameli 10 - 25014 Castenedolo (Brescia) – Italia

tel. +39 030 2134.1 / Fax +39 030 2134.300

Property of MARCO S.p.A reproduction prohibited. All rights reserved.

For further information visit our web site - [www.marco.it](http://www.marco.it)

Marco S.p.A Via Mameli 10 - 25014 Castenedolo (Brescia) – Italy

tel. +39 030 2134.1 / Fax +39 030 2134.300