

- **ABMESSUNGEN**
in mm
* kann bei anderen Motorfabrikaten abweichen

- **DIMENSIONS**
in mm
* may change with different motor manufacturer

- **ANSCHLÜSSE**
Losflansch DN25 PN16 - PP-ST oder G1" Innengewinde
Saug- und Druckseite abhängig von Drehrichtung.
Pumpe kann reversibel eingesetzt werden.

- **CONNECTIONS**
Lap Joint Flange DN25 PN16 - PP-ST or threaded G1" female
Suction and discharge side depends on direction of rotation.
Pump is reversible.

- **ANTRIEB**
Explosiongeschützter Drehstrom-Asynchronmotor mit Käfigläufer
Baugröße / Form: BG100 B5
Fabrikat / Typ: HEW DEx100
Zündschutzart: Ex db eb IIC T4 Gb

- **DRIVE**
Explosion-proof TEFC three phase asynchronous squirrel cage electric motor
Size: IEC 100 B5
Type: HEW DEx100
Ignition protection class: Ex db eb IIC T4 Gb

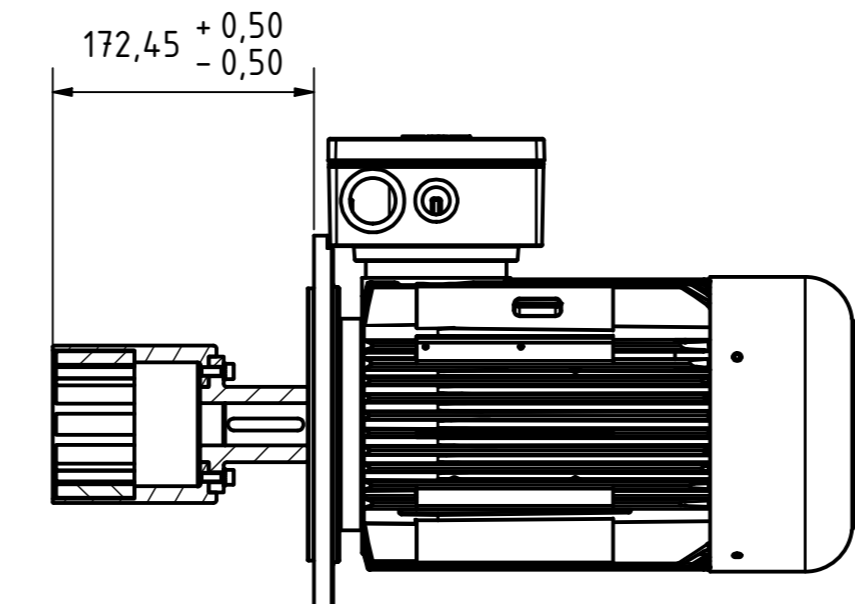

Alle Angaben unverbindlich, technische Änderungen vorbehalten! Technical data not binding and subject to change!
Copyright MARCH PUMPEN GmbH & Co.KG 2022

	MARCH PUMPEN GmbH & Co.KG Rätthausstraße 2 D-35394 Gießen info@march-pumpen.com www.march-pumpen.com		1:2	TEF-MAG 1500 P-F-V BG100 B5 HEW ABMESSUNGEN DIMENSIONS DRAWING_TM-1501-P-F-V-IEC100-HEW
	Gezeichnet 09.12.2021 Lach	Datum 09.12.2021 Name Lach		
a Adapterfl. BG100 Status Änderungen Datum Name	16.03.2022 PL	PL	PL	PL