

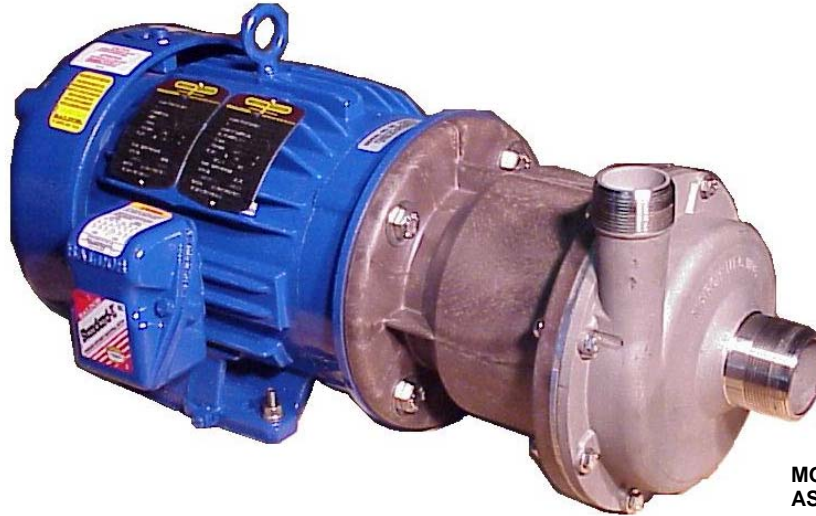

MARCH PUMPS

1819 PICKWICK AVE., GLENVIEW, IL 60026-1306, U.S.A
PHONE: (847) 729-5300 - FAX: (847) 729-7062
WWW.MARCHPUMP.COM

INSTRUCTIONS & REPAIR PARTS FOR MODEL TE-8S-MD



MODEL TE-8S-MD
ASS'Y. P/N 0157-0030-0100

RATING AND SPECIFICATIONS

MODEL NO.	CONNECTORS		ELECTRICAL			GPM AT LISTED HEAD						PSI GAGE	DIMENSIONS			PACK WT.
	INLET	OUTLET	HP	VOLTS	AMPS	1 FT.	10 FT.	30 FT.	50 FT.	70 FT.	90 FT.		HT.	WD.	LG.	
TE-8S-MD	2" MPT	1½" MPT	5	230/460	12.6/6.3	135	130	124	116	92	52	41.6	9¾"	10-¾"	25"	162 lbs.

PUMP CONSTRUCTION & SERVICING

March "Orbital" Magnetic Drive Pumps eliminate the conventional shaft seals found in most pumps. This means that there is no rotating shaft or seal to wear and allow the liquid being pumped to leak out. The only seal in the pump is a stationary Viton "O" ring seal between the front and the rear Housings.

The pump can be serviced with the use of an adjustable wrench. The only moving part in the pump, other than the motor, is the Impeller-Magnet Assembly which rotates on a stationary ceramic spindle and up against a ceramic thrust washer. These are the only parts that might wear, and may require replacement. See the Repair Parts List for replacement parts.

ELECTRICAL AND OPERATION

The standard pump has a TEFC severe duty motor, 230/460 Volts, 60 Cycle, 3 phase, 3450 R.P.M. rated as continuous duty. A junction box is located on the side of the motor for making the electrical hook up. The wiring instructions are located on the motor label or on the junction box cover. The motor has U.L. yellow card recognition.

March Pumps rely on the liquid being pumped to lubricate the Impeller-Magnet assembly bushing spinning on the stationary ceramic spindle. The direction of motor rotation should be clockwise looking into the inlet of the pump.

Totally enclosed explosion proof and special voltage motors are available upon special order.

PUMP MATERIALS

Metal wetted parts are fabricated from 316 S.S. The stationary spindle and Thrust Washers are made of porcelain ceramic. The "O" ring for the housing is Viton rubber. The bushing in the Impeller Assembly is carbon. There are no other materials in contact with the solution. Contact the factory for other materials that are available, or if you are uncertain of the material compatibility with your specific solution.

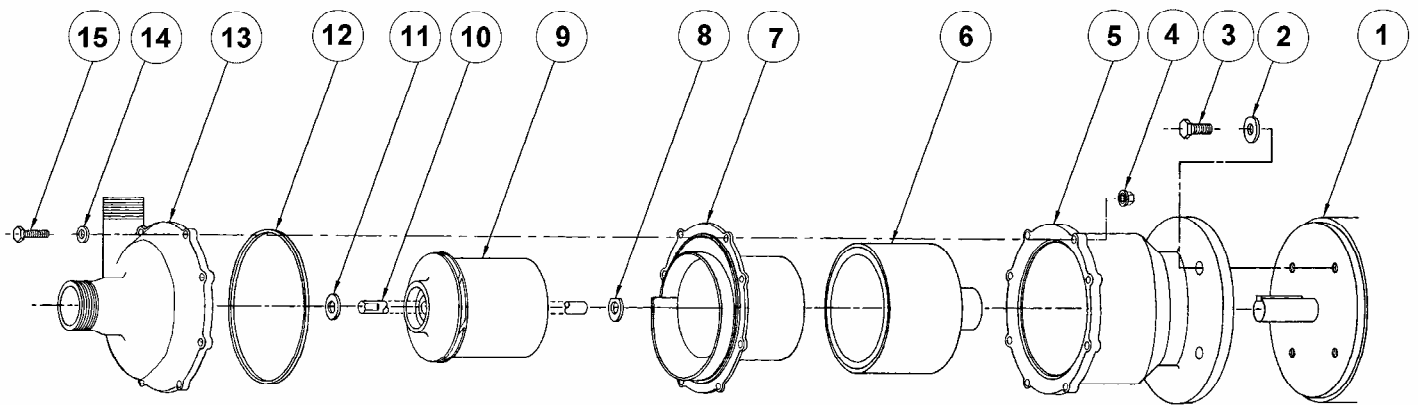

MODEL TE-8S-MD REPAIR PARTS LIST

ITEM	DESCRIPTION	QTY.	PART NUMBER
15	¼-20 X 1½" Long Hex Hd Mach. Screw	8	0153-0011-1000
14	Washer (Split)	8	0157-0037-1000
13	Pump Housing 316 S.S.	1	0157-0030-0000
12	7¼ I.D. X 1/8 Thk. "O" Ring Viton	1	0157-0011-1000
11	Thrust Washer Front	1	0157-0001-1000
10	Impeller Shaft	1	0157-0002-1000
9	Impeller Final Assembly 316 S.S. w/Carbon bushing	1	0157-0029-0500
8	Thrust Washer Rear	1	0157-0009-1000
7	Magnet Dividing Housing 316 S.S.	1	0157-0028-0000
6	Drive Magnet Holder Assembly	1	0157-0005-0100
5	Motor Connecting Bracket	1	0157-0100-1000
4	Hex Nut	8	0156-0053-1000
3	½ - 13 X 1" Long Hex Hd Cap Screw	4	0160-0031-1000
2	Washer	4	0160-0032-1000
1	Motor Explosion Proof	1	0157-0042-1000
1	Motor TEFC, Chemical Duty	1	0157-0065-1000

Contact factory for other materials and/or parts not listed.

LIMITED WARRANTY

March pumps are guaranteed only against defects in workmanship or materials for a period of one year from date of manufacture pumping water. On all other solutions, contact the factory for application assistance. March Pump Application Worksheet 750-130-10 is available for additional warranty information.

