

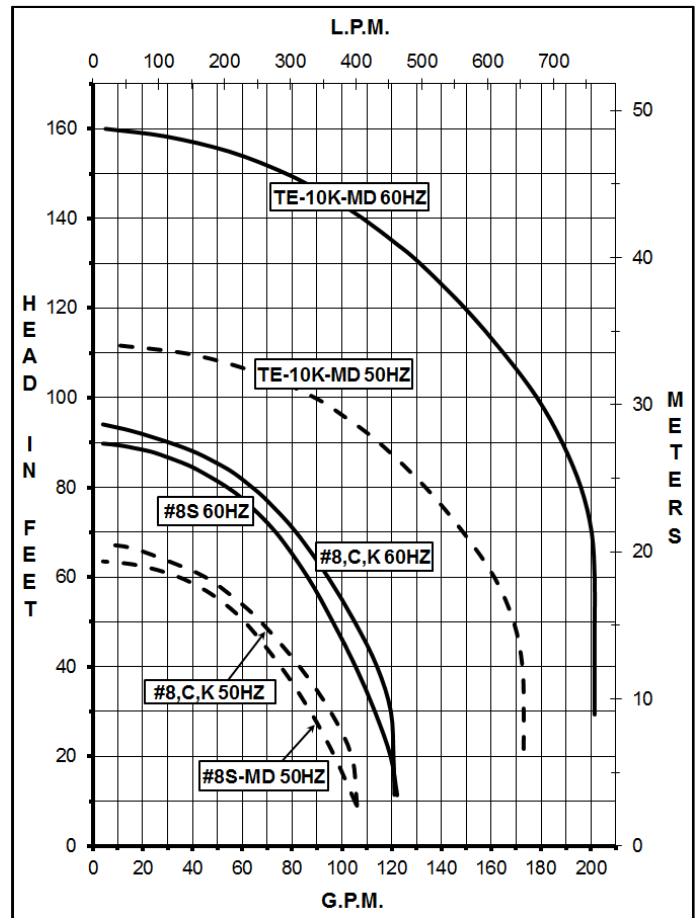

MARCH PUMPS

1819 PICKWICK AVE., GLENVIEW, IL 60026-1306, U.S.A
 PHONE: (847) 729-5300 - FAX: (847) 729-7062
 WWW.MARCHPUMP.COM

TE-8C-MD, TE-8K-MD TE-8S-MD TE-10K-MD

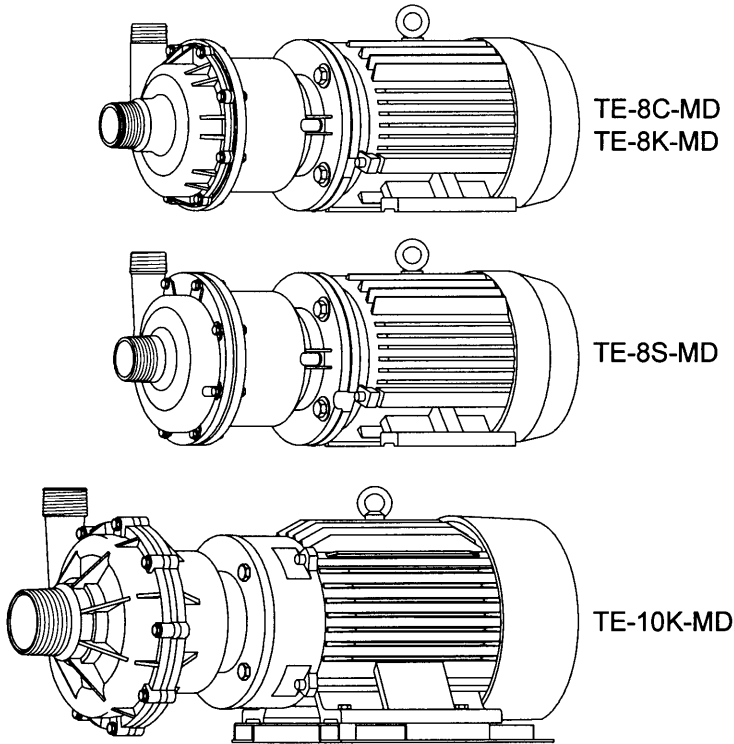

MODEL ABBREVIATIONS:

C = Polypropylene, K = Kynar, S = Stainless Steel
 TE = Totally Enclosed Fan Cooled Motor, MD = Magnetic Drive

DESCRIPTION: Series 8 & 10 are centrifugal magnetic drive pumps, eliminating the need for a shaft seal. These pumps can be serviced with an adjustable wrench. Screws should be tightened in sequence and uniformly. Do not over tighten the screws or you may crush the plastic housing bosses. See the repair parts list for a breakdown of replacement parts.

OPERATION: These pumps are not self-priming, lack a suction lift, and thus require a **flooded suction**. These pumps **cannot be run dry** because the impeller requires the liquid being pumped for lubrication. The direction of motor rotation should be clockwise when facing the inlet of the pump. For liquids with a specific gravity greater than water, have a higher viscosity, or for elevated temperatures, a trimmed impeller may be necessary. For application assistance, contact March Pump.

ELECTRICAL: Models are 230/460V, 3 phase, TEFC. Motors are U.L. listed and rated for continuous duty Explosion proof and special voltage motors are available upon special order.

NOTES: All specifications & data are based on pumping water & are intended as a guideline only. Specifications may vary with different motors.

When replacing impeller bushings on the TE-8 models in the field, the plastic bushings must be bored to size after they have been pressed into the impeller. Bore to 0.630/0.632 I.D. The carbon & ceramic bushings are to finished size and do not require boring. When attaching the drive magnet to the motor shaft, position the face of the drive magnet 3/8 inch below (For TE-8) and 3/16 inch above (For TE-10) the face of the motor bracket.

LIMITED WARRANTY: March pumps are guaranteed only against defects in workmanship or materials for a period of one year from date of manufacture pumping water. For the complete warranty and to register online go to www.marchpump.com/warranty-registration

SPECIFICATIONS			TE-8C-MD	TE-8K-MD	TE-8S-MD	TE-10K-MD
Max Flow	50Hz	lpm	400		400	654
	60Hz	gpm	120		120	200
Max Head	50Hz	m	20		19.3	34.1
	60Hz	ft (psi)	95 (41.1)		90 (39)	160 (69.3)
Inlet			2" MPT		2" MPT	3" MPT
Outlet			1-1/2" MPT		1-1/2" MPT	2" MPT
Max Internal Pressure	psi		50	75	200	75
	bar		3.4	5	13	5
Max Liquid Temperature	°F		190	200	250	190
	°C		87	93	121	87
Packed Weight		kg/lbs	72.5/160		81.5/180	118/260
Motor Type			TEFC 3 Phase		TEFC 3 Phase	TEFC 3 Phase
50Hz	190V	Watts - Amps	1895 - 9.2		3310 - 15	
	380V	Watts - Amps	1895 - 4.6		3310 - 7.5	5700 - 14.2
		Kw - Rpm	2.2 - 2850		3.7 - 2850	5.59 - 2850
60Hz	230V	Watts - Amps	2983 - 7.8		5030 - 12.6	9350 - 22.8
	460V	Watts - Amps	2983 - 3.9		5030 - 6.3	9350 - 11.4
		Hp - Rpm	3 - 3450		5 - 3450	10 - 3450
Electrical Connection			Conduit Box		Conduit Box	Conduit Box
Overall Pump Dimensions in Inches / cm	Height		10.86 / 27.5		10.86 / 27.5	13.32 / 33.8
	Width		12.73 / 32.3		12.73 / 32.3	13.94 / 35.4
	Length		24.68 / 62.6		24.68 / 62.6	30.74 / 78.0

CAUTION IN ASSEMBLY AND DISASSEMBLY: On the TE-10, the magnetic coupling in the pump is strong enough to warrant caution. When servicing the pump, the attraction of the impeller magnet and drive magnet may pull the impeller from your grasp. When assembling, hold onto the outer diameter of the impeller vanes with both hands and gently engage the impeller into the magnet field. Hold the impeller firmly and resist the magnetic attraction as you slowly put the impeller back in. The magnetic forces are strongest between 1/3 to 2/3 of engagement and will diminish when the magnets become aligned. Do not allow the impeller to snap into the rear housing, doing so may result in damage. Exercise caution in placing any of the magnets near steel, tools, or other sensitive instruments as doing so may result in damage or personal injury.

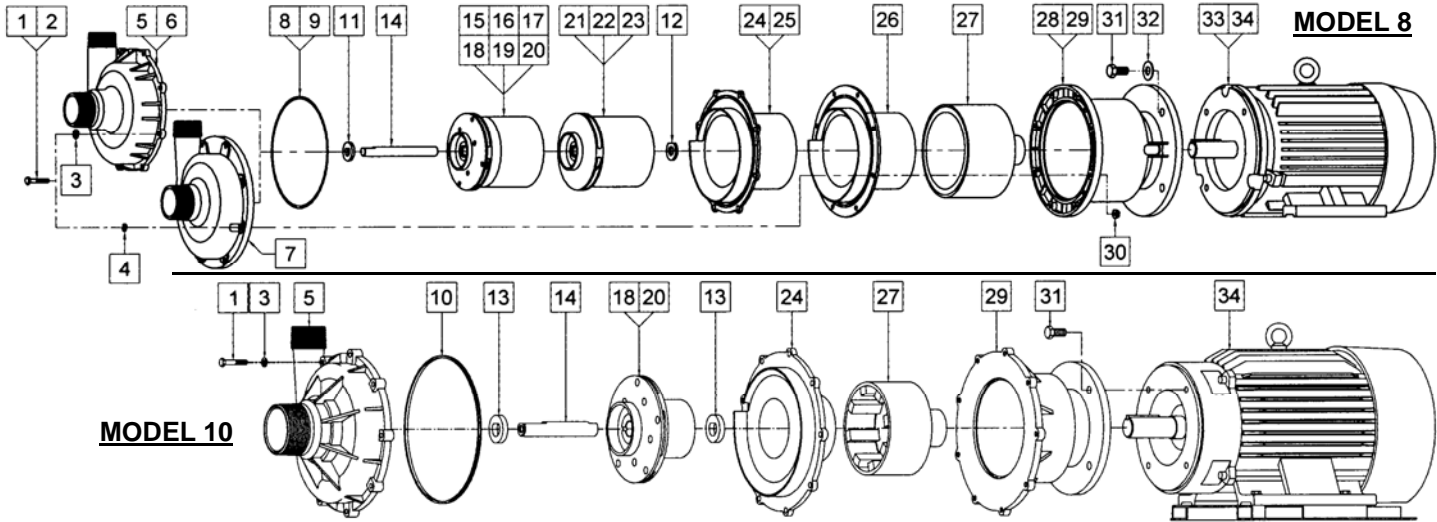

REPAIR PARTS LIST

ITEM	DESCRIPTION	MATERIAL	TE-8C-MD, TE-8K-MD TE-8S-MD			TE-8C-MD	TE-8K-MD	TE-8S-MD	TE-10K-MD			TE-10K-MD
			SIZE (INCHES)	QTY	PART #				SIZE (INCHES)	QTY	PART #	
1	Screw	Stainless Steel	1/4-20 x 1-1/2 Lg.	8	0153-0011-1000	S	S	S	5/16-18 x 1-3/4 Lg.	9	0160-0029-1000	S
2	Screw (Used w/metal motor bracket)	Stainless Steel	1/4-20 x 1-1/4 Lg.	8	0157-0036-1000	O	O	O				
3	Washer	Stainless Steel	1/4 ID x 5/8 OD	8	0157-0023-1000	S	S		5/16 ID x 5/8 OD	9	0160-0030-1000	S
4	Lock Washer (Split)	Stainless Steel	1/4	8	0157-0037-1000			S				
5	Pump Housing	Kynar		1	0157-0052-1000		S			1	0161-0008-1000	S
6	Pump Housing	Polypropylene		1	0157-0007-1000	S						
7	Pump Housing	316 Stainless		1	0157-0030-0000			S				
8	"O" Ring	Viton	.157CS x 7.244 ID	1	0157-0011-1000	S	S	S				
9	"O" Ring	Viton/Teflon	1/8 CS x 7-1/2 OD		0157-0032-1000	O	O	O				
10	Gasket	Viton							9.750 ID x 10 OD	1	0161-0043-1000	S
11	Thrust Washer (Front)	Ceramic		1	0157-0001-1000	S	S	S				
12	Thrust Washer (Rear)	Ceramic		1	0157-0009-1000	S	S	S				
13	Thrust Washer (Front & Rear)	Ceramic								2	0161-0001-1000	S
14	Shaft	Ceramic		1	0157-0002-1000	S	S	S		1	0161-0002-1000	S
15	Impeller w/Ryton Bushing	Polypropylene		1	0157-0004-0200		S					
16	Impeller w/Carbon Bushing	Polypropylene		1	0157-0004-0500	O						
17	Impeller w/Mica Teflon Bushing	Polypropylene		1	0157-0004-0700	O						
18	Impeller w/Carbon Bushing	Kynar		1	0157-0050-0500		S			1	0161-0005-0400	S
19	Impeller w/Ryton Bushing	Kynar		1	0157-0050-0200		O					
20	Impeller w/Mica Teflon Bushing	Kynar		1	0157-0050-0700		O			1	0161-0005-0600	O
21	Impeller w/Carbon Bushing	316 Stainless		1	0157-0029-0500			S				
22	Impeller w/Ryton Bushing	316 Stainless		1	0157-0029-0200			O				
23	Impeller w/Mica Teflon Bushing	316 Stainless		1	0157-0029-0700			O				
24	Rear Housing	Kynar		1	0157-0053-1000	S	S			1	0161-0009-1000	S
25	Rear Housing	Ryton		1	0157-0038-0000	O						
26	Rear Housing	316 Stainless		1	0157-0028-0000			S				
27	Drive Magnet			1	0157-0005-0100	S	S	S		1	0161-0031-0100	S
28	Motor Bracket	Plastic		1	0157-0100-1000	S	S	S				
29	Motor Bracket	Metal		1	0157-0008-0000	O	O	O		1	0161-0007-0000	S
30	Lock Nut (Serrated)	Stainless	1/4-20	8	0156-0053-1000	S	S	S				
31	Screw	Stainless	1/2-13 x 1 Lg.	4	0160-0031-1000	S	S	S	1/2-13 x 1 Lg.	4	0160-0031-1000	S
32	Washer	Stainless	1/2 ID x 1-1/4 OD	4	0160-0032-1000	S	S	S				
33	TEFC Motor, 3HP, 230/460V, 3Ph			1	0157-0012-1000	S	S					
34	TEFC Motor, 5HP, 230/460V, 3Ph			1	0157-0065-1000	O	O	S				
35	TEFC Motor, 10HP, 3 Phase									1	0161-0012-1000	S
W1	Wet End Kit (Items: 1,3,6,8,11,12,14,15,24,30)			1	0157-0085-0100	S						
W2	Wet End Kit (Items: 1,3,5,8,11,12,14,18,24,30)			1	0157-0086-0100		S					
W3	Wet End Kit (Items: 1,3,5,10,13,14,18,24)									1	0161-0035-0100	S

NOTE: Contact Factory for other materials and/or parts not listed.

Legend: S = Standard, O = Optional

MATERIALS IN CONTACT WITH SOLUTION:

TE-8C-MD: Polypropylene, Kynar/Carbon Filled, Viton, Teflon/Ryton/Carbon, Ceramic
 TE-8K-MD: Kynar/Carbon Filled, Viton, Carbon, Ceramic
 TE-10K-MD: Kynar/Carbon Filled, Ceramic, Viton, and Carbon

TE-8S-MD: 316 Stainless Steel, Viton, Carbon, Ceramic
 0157-0021-1000 R12