

CHANGES

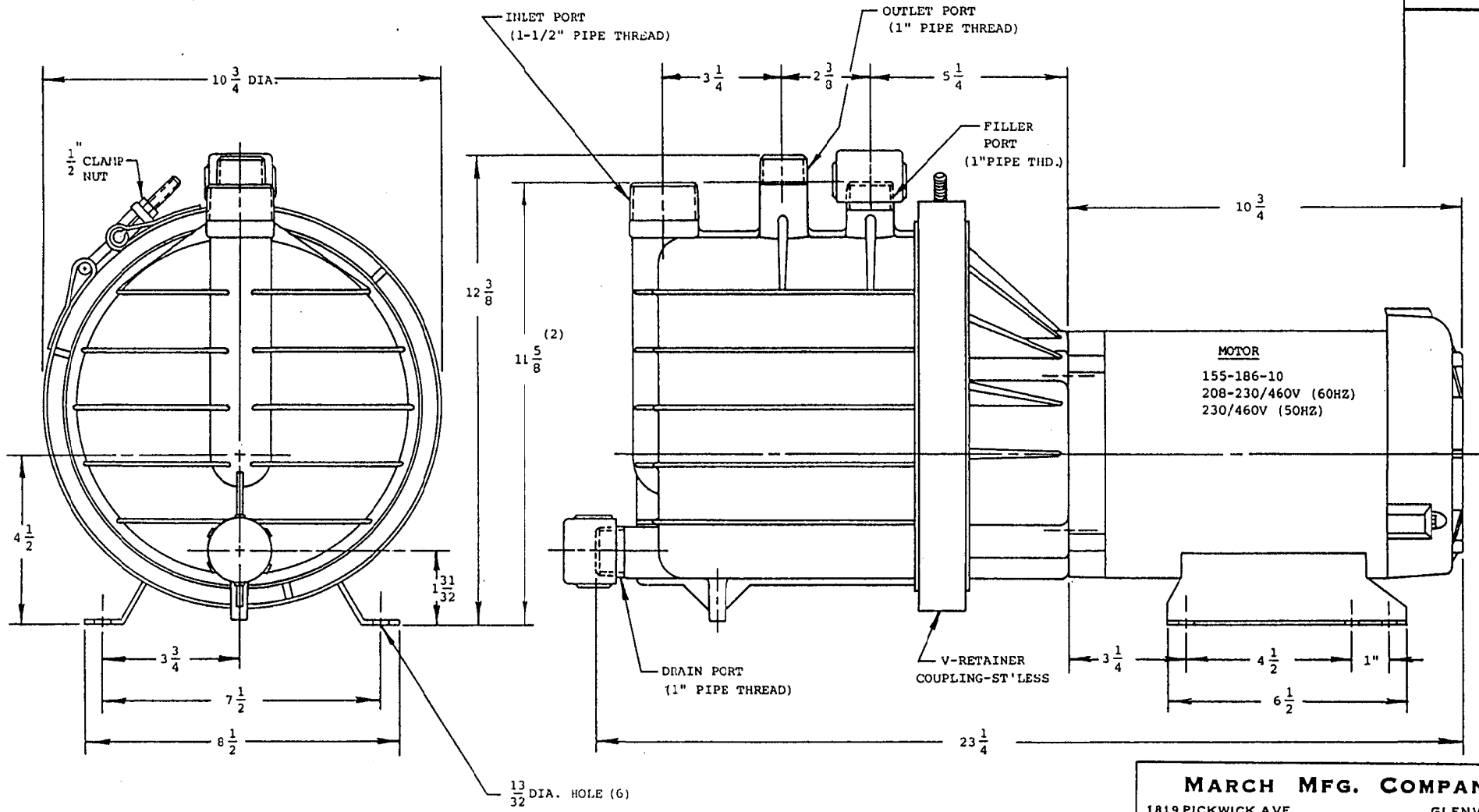

| | MODEL | ASSEMBLY No. |
|----------------|---------------------|--------------|
| (POLYP.) | SP-TE-7P-MD-3PH-1HP | 155-187-02 |
| (KYNAR/CARBON) | SP-TE-7K-MD-3PH-1HP | 155-188-02 |

| | | |
|---|---------------|----------------|
| MARCH MFG. COMPANY | | |
| 1819 PICKWICK AVE. | | GLENVIEW, ILL. |
| PART NAME PUMP ASSEMBLY SP-TE-7-MD (THREE PHASE) | | |
| MOTOR: MARATHON-TEFC-56 FRAME -1 HP | | |
| | SCALE 3/8"=1" | QTY. REQ. 1 |
| FINISH | DRAWN JT/HZ | DATE 2-5-96 |
| UNLESS OTHERWISE NOTED TOLERANCE ON FRACTIONS ± TOLERANCE ON DECIMALS ± | CHECKED | |
| | APPROVED | BIG |
| PART NUMBER 155 SERIES | | |

THIS DOCUMENT DISCLOSES SUBJECT MATTER IN WHICH MARCH MFG. CO. HAS PROPRIETARY RIGHTS. NEITHER RECEIPT NOR POSSESSION THEREOF CONFERES OR TRANSFERS ANY RIGHT TO REPRODUCE OR DISCLOSE THE DOCUMENT, ANY PART THEREOF, ANY INFORMATION CONTAINED THEREIN, OR ANY PHYSICAL ARTICLE OR DEVICE OR TO PRACTICE ANY METHOD OR PROCESS, EXCEPT BY WRITTEN PERMISSION FROM OR WRITTEN AGREEMENT WITH MARCH MFG. CO.